

Universal MATE-N-LOK Contacts

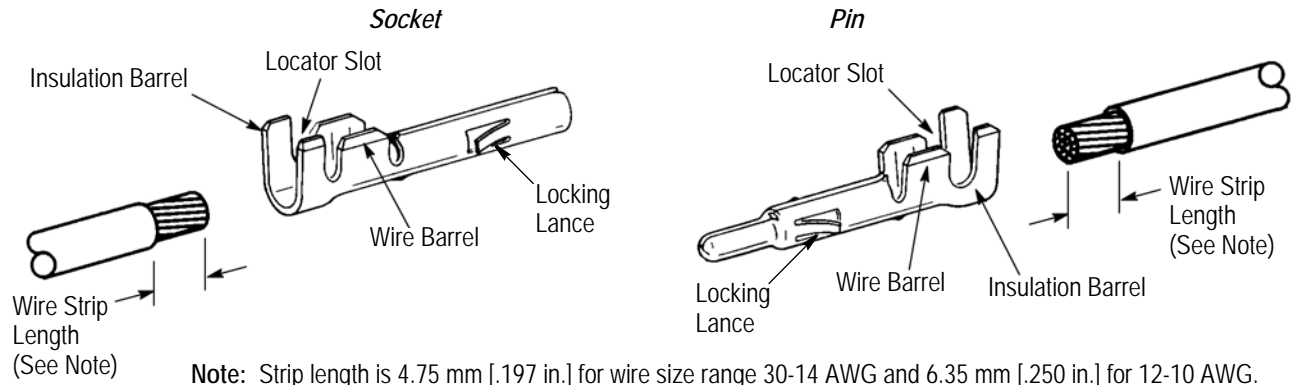

Note: Strip length is 4.75 mm [.197 in.] for wire size range 30-14 AWG and 6.35 mm [.250 in.] for 12-10 AWG.

WIRE		UNIVERSAL MATE-N-LOK CONTACT				HAND TOOLING (Instruction Sheet)
SIZE (AWG) RANGE	INSULATION DIAMETER (mm [in.])	LOOSE PIECE		STRIP FORM		
		PIN	SOCKET	PIN	SOCKET	
30-26	0.81-1.45 [.032-.057]	770672-[-]	770673-[-]	350924-[-]	350925-[-]	58439-[-] (408-9591)
24-18	1.02-2.54 [.040-.100]	350690-[-]	350689-[-] ◆	350561-[-]	350570-[-] ◆	91510-1 408-9479
		350690-[-]	640347-[-]	350561-[-]	350851-[-]	
		350706-[-] ■	—	350699-[-] ■	—	
20-14	1.52-3.30 [.060-.130]	350547-[-]	350550-[-]	350218-[-]	350536-[-]	91500-1 (408-9476)
		350705-[-] ■	—	350687-[-] ■	—	
		350669-[-] †	—	350654-[-] †	—	
	3.30-5.08 [.130-.200]	350552-[-]	350551-[-]	350538-[-]	350537-[-]	91508-1 †† (408-8547) 91506-1 †† (408-8547)
350707-[-] ■		—	350700-[-] ■	—		
18-14	3.30-5.08 [.130-.200]	350918-[-]	350919-[-]	350873-[-]	350874-[-]	91508-1 †† (408-8547) 91506-1 †† (408-8547)
12-10	5.08 [.200] Max	640309-[-]	640310-[-]	350922-[-]	350923-[-]	69710-1 †† (Without Dies) (408-2095) and Die 58380-[-]

◆ Stock thickness is 0.25 mm [.010 in.]; all others is 0.30 mm [.012 in.]      ■ Split pin contact

† Use Hand Tool 91508-1 for wire size 20-18 AWG, Hand Tool 91506-1 for wire size 16-14, Hand Tool 69710-1 and Die Set 583380-1 for 12 AWG, and Die Set 58380-2 for 10 AWG.

†† Grounding pin

Figure 1

1. INTRODUCTION

This instruction sheet covers the use of MATE-N-LOK contact and housing selection charts. MATE-N-LOK contacts and housings are divided into three categories: universal, commercial, and .140.

Read these instructions thoroughly to be sure the selected contacts are compatible with the specified housings, and the selected wire and application tooling are compatible with the contacts.

Reasons for reissue of this document are provided in Section 5, REVISION SUMMARY.

## Commercial MATE-N-LOK Contacts

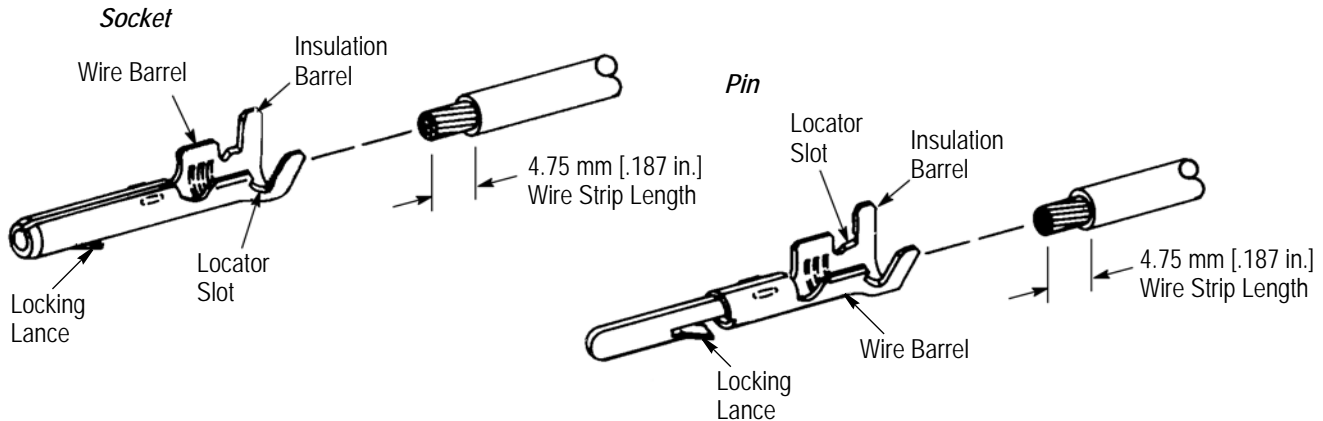

WIRE		COMMERCIAL MATE-N-LOK CONTACT				HAND TOOLING (Instruction Sheet 408-8547)
SIZE (AWG) RANGE	INSULATION DIAMETER (mm [in.])	LOOSE PIECE		STRIP FORM		
		PIN	SOCKET	PIN	SOCKET	
30-22	0.191 [.075] (Max)	61174-[-]	61173-[-]	350079-[-]	350078-[-]	91515-1
24-18	1.09-1.91 [.043-.075]	60618-[-]	60617-[-]	61116-[-]	61114-[-]	91528-1
24-20	1.52-2.54 [.060-.100]	60618-[-]	60617-[-]	61116-[-]	61114-[-]	91512-1
		—	61473-[-]	—	61115-[-]	
20-14	2.54-3.30 [.100-.130]	60620-[-]	60619-[-]	61118-[-]	61117-[-]	91504-1
(1) 18 and (1) 16 or (2) 18	2.92 [.115] (Max) and 3.30 [.130] (Max) ‡	350639-[-]	350638-[-]	350558-[-]	350557-[-]	91504-1

‡ 2.92 mm [.115 in.] (max) each for applicator termination and 3.30 mm [.130 in.] (max) combined for hand tool termination

Figure 2

The contacts must be installed into the appropriate housings and not switched between various categories.

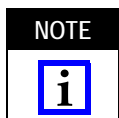

*Dimensions in this instruction sheet are in metric units [with U.S. customary units in brackets]. Figures are not drawn to scale.*

## 2. DESCRIPTION

### 2.1. Contacts

Universal pin and socket contacts (see Figure 1) are available in five different wire ranges covering sizes 30 to 10 AWG with an insulation diameter range of 0.81 through 5.08 mm [.032 through .200 in.].

Commercial pin and socket contacts (see Figure 2) are available for terminating wire sizes 30 to 14 AWG.

.140 pin and socket .140 feature a stabilizing barrel and are available for terminating wire sizes 20 to 10 AWG.

The loose-piece contacts are designed for hand tool or pneumatic tool applications. The strip-form contacts

are terminated using miniature quick-change applicators used in the AMP-O-ELECTRIC\* machine, AMPOMATOR\* automatic lead-making machine, or the standard and mini-single end lead machine (SELM and Mini-SELM). Consult your Representative for assistance in selecting the machine and applicator that will best suit your needs.

### 2.2. Housings

.140 housings (see Figure 4) have a temperature rating of -55 to +105°C [-65 to 221°F] and a maximum voltage/current rating of 250 Vac at 28 amperes per contact.

Universal housings (see Figure 5) have a temperature rating of -55 to +105°C [-65 to 221°F] and a maximum voltage/current rating of 600 Vac at 19 amperes per contact. Pin and socket contacts can be used in either plug or cap housings.

Commercial housings (see Figure 6) have a temperature rating of -55 to +105°C [-65 to 221°F] and a maximum voltage/current rating of 250 Vac at 19 amperes per contact.

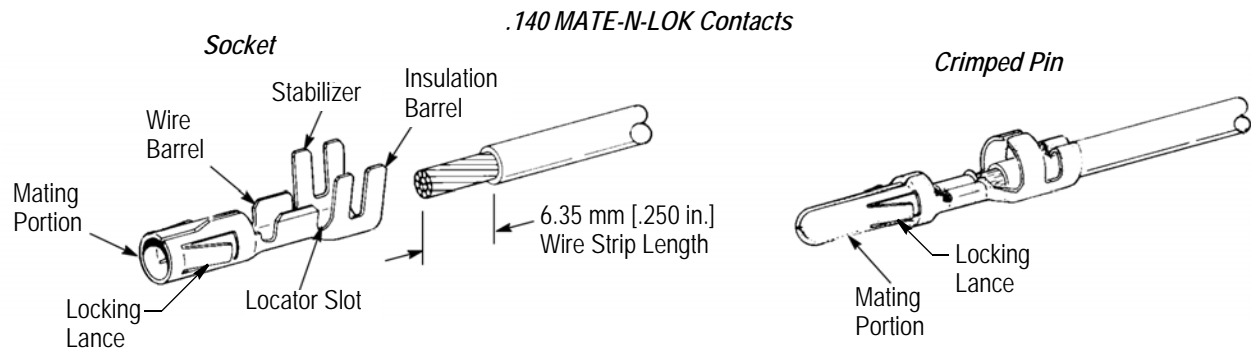

WIRE		.140 MATE-N-LOK CONTACT				HAND TOOLING (Instruction Sheet)
SIZE (AWG) RANGE	INSULATION DIAMETER (mm [in.])	LOOSE PIECE		STRIP FORM		
		PIN	SOCKET	PIN	SOCKET	
20-14	2.54-4.57 [.100-.180]	350389-[-]	350388-[-]	61627-[-]	61626-[-]	90247-1 (408-7434)
14-10		350391-[-]	350390-[-]	350201-[-]	350200-[-]	69710-1 (Without Dies) (408-2095) and Die 58373-[-] or 58374-[-]

Figure 3

### 3. SELECTION

Determine the housing type (universal, commercial, or .140) to be assembled. Refer to the listings of compatible contacts, and select the contact type and recommended wire size. Make contact selections from Figures 1, 2, and 3. Make housing selections from Figures 4, 5, and 6. Select contacts as follows:

- Determine the appropriate wire size to be used with the contact according to Column 1. Make certain the wire insulation diameter is within the range specified in Column 2.
- Columns 3, 4, 5, and 6 indicate the appropriate loose-piece and strip-form contacts for the selected wire size. Check that these base part numbers correspond with those on the package or reel.
- Column 7 indicates the appropriate hand tooling to be used to crimp loose-piece contacts. Machines for strip-form contacts are listed in Paragraph 2.1.

### 4. CONTACT INSERTION AND EXTRACTION

The following tools are recommended:

Contact Type	Insertion Tool	Extraction Tool
Universal	91002-1	1804030-1
Commercial	455830-1	305183 or 465644
.140	None ♦	318845-1

♦ Not necessary because of the large wire size

To insert a contact into a housing:

- Place the tweezer-shaped tool over the wire with the tool insertion tip behind the contact insulation barrel.

- Insert the contact into the housing cavity until the contact locking lance is fully seated.

To extract a contact from a housing:

- Gently push the wire of the contact to be removed.
- From the mating face of the housing, slide the tube-shaped tool into the contact cavity of the contact to be removed until the locking lances are encased.
- Lighted push the tool while pulling the wire.

### .140 MATE-N-LOK Housings

Plug (Socket)

Cap (Pin)

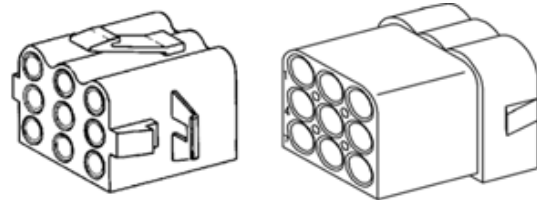

### .140 MATE-N-LOK HOUSING

NO. OF CIRCUITS	PLUG	CAP
2	350344-[-]	350345-[-]
3	350346-[-]	350347-[-]
4	480510-[-]	480512-[-]
9	480585-[-]	480586-[-]
	480672-[-]	480673-[-]

Figure 4

Universal MATE-N-LOK Housings

Plug (Socket)

Cap (Pin)

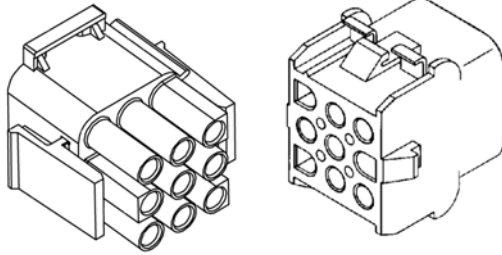

Commercial MATE-N-LOK Housings

Plug (Socket)

Cap (Pin)

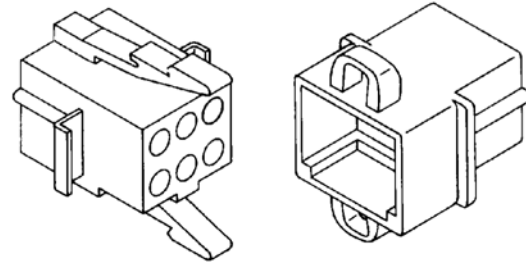

UNIVERSAL MATE-N-LOK HOUSING			
NO. OF CIRCUITS	PLUG	CAP	UL 94 MATERIAL RATING
1	350867-[]	770421-1	V-2
	350865-[]	350866-[]	V-0
2	480698-[]	480699-[]	V-2
	350777-[]	350778-[]	V-0
3	480700-[]	480701-[]	V-2
	350766-[]	350767-[]	V-0
4	480702-[]	480703-[]	V-2
	350799-[]	350780-[]	V-0
5	480763-[]	480764-[]	V-2
	350809-[]	350810-[]	V-0
6	480704-[]	480705-[]	V-2
	350715-[]	350781-[]	V-0
	640585-[]	—	V-2
8	640581-[]	—	V-0
	640586-[]	—	V-2
9	640582-[]	—	V-0
	480706-[]	480707-[]	V-2
12	350720-[]	350782-[]	V-0
	480708-[]	480709-[]	V-2
15	350735-[]	350783-[]	V-0
	480710-[]	480711-[]	V-2
	350736-[]	350784-[]	V-0

Figure 5

COMMERCIAL MATE-N-LOK HOUSING		
NO. OF CIRCUITS	PLUG	CAP
1	480349-[]	480350-[]
	480349-[]	480351-[]
2	480318-[] †	480319-[] †
	480303-[] †	480305-[] †
3	480304-[] †	480305-[] †
	480424-[] †	480426-[] †
4	480425-[] †	480426-[] †
	480270-[] †	480271-[]
6	480273-[] †	480276-[] †
	480270-[] †	480340-[]
	480270-[] †	—
8	480283-[] †	480284-[]
	480283-[] †	480345-[]
9	480274-[] †	480277-[] †
10	480285-[] †	480286-[]
	480285-[] †	480339-[]
12	480275-[] †	480278-[] †
	480287-[] †	480288-[]
15	480323-[] †	480324-[] †
16	480438-[] †	480439-[]

† Housing accepts double-wire applications where individual insulation diameters do not exceed 2.92 mm [.115 in.].

Figure 6

5. REVISION SUMMARY

Since the previous version of this document, the following changes were made:

- Corrected part number in Figure 1.