

AIR PUBLICATION

113D-1825-1

Formerly
A.P. 4343C Vol. 1
Book 3, Sect. 5, Chap. 1

PLESSEY STANDARD BREEZE CONNECTORS

GENERAL AND TECHNICAL INFORMATION

BY COMMAND OF THE DEFENCE COUNCIL

T. Dunnett

Ministry of Defence
FOR USE IN THE
ROYAL NAVY
ROYAL AIR FORCE

(Prepared by the Ministry of Technology)

AMENDMENT RECORD SHEET

To record the incorporation of an Amendment List in this publication,
sign against the appropriate A.L. No. and insert the date of incorporation.

A.L. No.	AMENDED BY	DATE
1		
2		
3		
4		
5		
6		
7		
8		
9		
10		
11		
12		
13		
14		
15		
16		
17		
18		
19		
20		
21		
22		
23		
24		
25		
26		
27		
28		
29		
30		
31		
32		
33		

A.L. No.	AMENDED BY	DATE
34		
35		
36		
37		
38		
39		
40		
41		
42		
43		
44		
45		
46		
47		
48		
49		
50		
51		
52		
53		
54		
55		
56		
57		
58		
59		
60		
61		
62		
63		
64		
65		
66		

LIST OF CHAPTERS

1. Plessey standard breeze connectors

Chapter 1

PLESSEY STANDARD BREEZE CONNECTORS

CONTENTS

	<i>Page</i>		<i>Page</i>
<i>Introduction</i>	3	<i>Contact arrangements</i>	12
Description	3	Instructions for use	12
<i>Fixed unit</i>	3	<i>Preparations</i>	12
<i>Normal or reverse free unit</i>	5	<i>Wiring connectors</i>	13
<i>Bulkhead unit</i>	8	<i>Assembly of cable fittings</i>	14
<i>Pressurized bulkhead unit</i>	9	<i>Ejector tool</i>	15
<i>Special purpose connectors</i>	9	<i>Renewing cables</i>	15
<i>Contacts</i>	11	<i>Mounting connectors</i>	15
<i>Connector accessories</i>	11	<i>Mating connectors</i>	15
<i>Spares and replacements</i>	12		

ILLUSTRATIONS

<i>Fig.</i>		<i>Page</i>	<i>Fig.</i>		<i>Page</i>
1	Fixed unit—fixed pins version	3	14	Free unit (short reach), stages of development	10
2	Fixed unit—loose pins version	4	15	Heavy duty pressurised bulkhead unit	10
3	Fixed unit—climatic-proof	4	16	Quick release fixed and free units, stages of development	11
4	Fixed unit (exploded) climatic-proof	4	17	Cut ferrule used with screened cable ..	13
5	Fixed unit, stages of development ..	5	18	Preparation of ends of screened cable	13
6	Free unit (exploded) with coupling nut and cut ferrule, climatic-proof ..	6	19	Ejector tool	15
7	Free unit (exploded) with coupling nut and inner and outer ferrules, vibration proof	6	20	Contact arrangements	16
8	Free unit, stages of development ..	7	21	Contacts	39
9	Bulkhead unit, climatic-proof ..	8	22	Panel piercing details, fixed unit ..	40
10	Bulkhead unit, stages of development	8	23	Panel piercing details, bulkhead unit	41
11	Pressurised bulkhead unit	9	24	Panel piercing details, pressurized unit	42
12	Pressurised bulkhead unit, stages of development	9	25	Panel piercing details, heavy duty bulkhead unit	43
13	Fixed unit (detachable leads), stages of development	9	26	Panel piercing details, quick release unit	43
			27	Dimensions fixed unit detachable leads	44

ILLUSTRATIONS (continued)

<i>Fig.</i>		<i>Page</i>	<i>Fig.</i>		<i>Page</i>
28	Dimensions free unit	44	36	Inner and outer ferrules	49
29	Dimensions short reach free unit ..	45	37	Ferrules for plastic tubing	50
30	Fixed unit sealing cap	46	38	Conduit ferrule Type H	50
31	Fixed unit screening cap	46	39	Conduit ferrule Type G	51
32	Coupling unit	47	40	Elbow assembly	51
33	Fixed unit shroud	47	41	Tee connector	52
34	Ferrule plate assembly	48	42	Cut ferrule round base	53
35	Clamp rings	49	43	Cut ferrule square base	53

TABLES

<i>No.</i>		<i>Page</i>	<i>No.</i>		<i>Page</i>
1	Fixed unit (aluminium)	17	20	Dimensions and panel piercing details (quick-release) unit	43
2	Normal free unit (aluminium)	19	21	Dimensions (fixed unit) (detachable leads)	44
3	Reverse free unit (aluminium)	21	22	Dimensions (free unit)	44
4	Bulkhead unit (aluminium)	23	23	Dimensions (short-reach free unit) ..	45
5	Pressurized bulkhead unit (aluminium)	25	24	Spares and replacements (uprated versions)	45
6	Fixed unit (brass and steel)	27	25	Fixed unit sealing cap	46
7	Normal free unit (brass and steel) ..	29	26	Fixed unit screening cap	46
8	Reverse free unit (brass and steel) ..	31	27	Coupling unit	47
9	Bulkhead unit (brass and steel)	33	28	Fixed unit shroud	47
10	Fixed unit (detachable leads)	35	29	Ferrule plate assembly	48
11	Free unit (short-reach)	35	30	Clamp rings	49
12	Heavy duty pressurized bulkhead connector block	36	31	Inner and outer ferrules	49
13	Quick-release fixed and free units ..	36	32	Ferrules for plastic tubing	50
14	Thermocouple unit	37	33	Conduit ferrule (Type H)	50
15	Contacts	38	34	Conduit ferrule (Type G)	51
16	Dimensions and panel piercing details (fixed unit)	40	35	Elbow assembly	51
17	Dimensions and panel piercing details (bulkhead unit)	41	36	Tee connector	52
18	Dimensions and panel piercing details (pressurized) bulkhead unit	42	37	Cut ferrule (round base)	52
19	Dimensions and panel piercing details (heavy duty) bulkhead unit	43	38	Cut ferrule (square base)	53
			39	Ejector tool	54

LEADING PARTICULARS

Current ratings:
7A, 19A, 37A and 64A

Voltage rating (sea level):
250 V a.c. or 350 V d.c.

Contact details:
brass, silver-plated; crimped or soldered connections

Contact resistance:
less than 2 milliohms for currents less than 10A
less than 1 milliohm for currents greater than 10A

Temperature range:
-65 degrees C to +150 degrees C (uprated types)

Altitude ratings:
208 V a.c. or 300 V d.c. at 50,000 ft.

Compatibility:
resistant to water and fluids

Lubricants:
Polypaste 300 to DTD 900/4669 for threads;
ZX-36 for cables, etc.

Introduction

1. The Plessey standard breeze range of connectors were designed primarily for use in d.c. systems but are not restricted to low voltages provided due consideration is paid to voltage, frequency, etc. The connectors are climatic proof provided they are not fully exposed. They are available in aluminium and steel shells in six sizes designated A, Z, B, C, D and E (a seventh size F was available in the early development stages of the connector; also, the early ranges included brass shells). Units in steel shells are fireproof (a fireproof unit passing d.c. will continue to operate for 5 minutes in a total flame envelopment of 1,000 degrees C. and will allow no passage of flame for 20 minutes).

2. Improved characteristics have been incorporated into Standard connectors to give them wider applications. The current designs of units are classified as follows:—

(1) *Climatic-proof and vibration-proof types.* These have been made splashproof by the suitable positioning of gaskets. The socket unit contains spring contacts which, together with the coupling nut (drilled with holes for wire locking), safeguard the unit against excessive vibration. Free movement of the pin contacts facilitates mating of the connectors. All the insulators, insulating rings and washers are of materials resistant to high temperature, and the mounting gaskets etc. are resistant to oils and hydrocarbons used in aircraft.

(2) *Climatic-proof, fireproof and vibration-proof types.* These are specifically for use on the engine side of a fireproof bulkhead and where excessive vibration is experienced. They are electrically and physically similar to and interchangeable with the types described under 2 (1), but the shells are of steel (nickel-plated) and high tensile steel fixing screws and stiffnuts are provided to secure the units against the affects of engine vibration.

(3) *Pressurized types.* These are for use on pressure cabin bulkheads. They have aluminium shells and are sealed against a pressure difference of 15 lb/in². They are not suitable for use in high temperatures.

3. The standard shell styles in the range provide for fixed, bulkhead and free units in the various shell sizes and twenty-three different contact arrangements. A wide variety of fittings is available to take screened or unscreened single or multi-core cables. The free units (viz. socket units) are supplied as "normal" or "reverse" (see para. 20).

4. Mismatching of units is prevented by the dispositions of their pin or socket contacts. Fixed units (plugs) including bulkhead units are fitted with pin contacts; free units (sockets) are fitted with socket contacts.

5. All units have progressed from their original designs and units at different stages are in existence. The use of earlier designs of units is not recommended and current versions of these units are supplied as replacements. The current versions are

those units incorporating the characteristics described in para. 2. However, a full list of the part numbers of all units in existence is given in Tables 1 to 14, which indicate the various stages of development, and the main features of each development stage are described below.

Description

Fixed unit (Tables 1 and 6)

Stage 1 (fixed-pins version)

6. This style of unit (fig. 1 and 5) was the original design; it consisted of an insulator of phenolic material, in which the pins are permanently moulded in position, and an aluminium, brass or steel shell machined from bar. The square flange is integral with the shell.

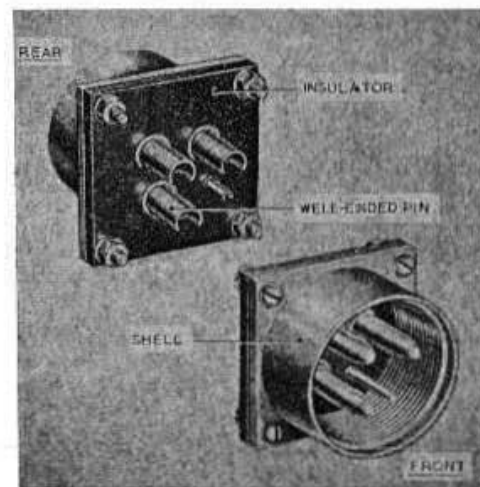

Fig. 1. Fixed unit—fixed pins version

7. Four nuts and bolts hold the unit together and secure the flange to a panel. The shell shrouds the pins and is internally threaded to receive the free unit shell. The pins have wells which are suitable for soldered connections only.

Stage 2 (loose-pins version)

8. In this style of unit (fig. 2 and 5), the insulator comprised two identical parts. In order to reduce creepage, the perimeters of the pin contact holes in these discs are formed with stepped barriers so that the surface area between the pins is increased. The bases of the pins are sandwiched between the insulators when they are clamped to the shell flange by the fixing bolts. In stage 2 units the flange corners are drilled and tapped to accept the fixing bolts.

Stage 3 (climatic-proof version)

9. In the stage 3 version (fig. 3, 4 and 5), two rubber insulator gaskets (on either face of the front insulator) and a shell gasket were introduced to

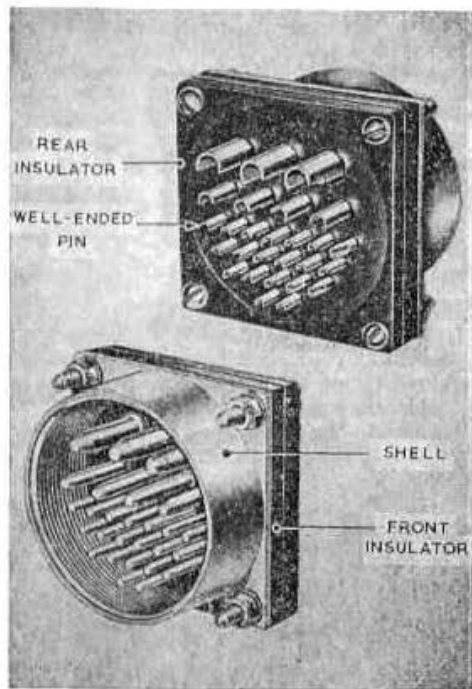

Fig. 2. Fixed unit—loose pins version

make the unit proof against climatic conditions (providing the unit is not fully exposed). The rear insulator is redesigned to accept pins that are suitable for crimped or soldered connections and is made deeper to shroud the connections.

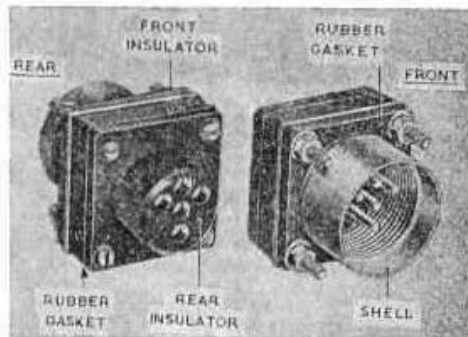

Fig. 3. Fixed unit—climatic-proof

10. The composite square flange is made up of the flange integral with the rear insulator, the front insulator disc together with its two gaskets, the flange integral with the shell, and the unit shell gasket. Four nuts and bolts hold the unit together and secure the flange to a panel.

Stage 4 (uprated version)

11. In the stage 4 version (fig. 5), the front and rear insulators were alkyd, the shell and rear insulator gaskets silicone rubber and a seating gasket of

silicone rubber (designed to accept the mating rim of the free unit) replaced the front insulator gasket of the stage 3 version. Also, a brass backing plate was introduced behind the rear insulator in order to prevent damage when the bolts are tightened. The changes leading to this stage enabled the unit to operate between ambient temperatures of -65 degrees C. and $+150$ degrees C.

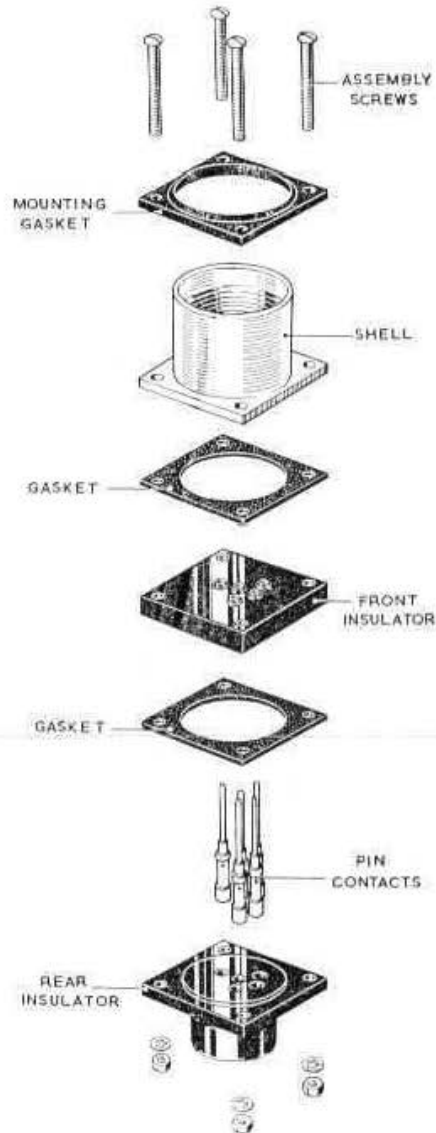

Fig. 4. Fixed unit (exploded)—climatic-proof

Stage 5 (improved fluid resistant version)

12. This version differed from stage 4 in that the shell and rear insulator gasket material was asbestos fibre. This change improved resistance to fluids and fire. These units are splash-proof and vibration-proof when assembled in aluminium shells and splash-proof, fireproof and vibration-proof when assembled in steel shells (para. 2(1) and 2(2)).

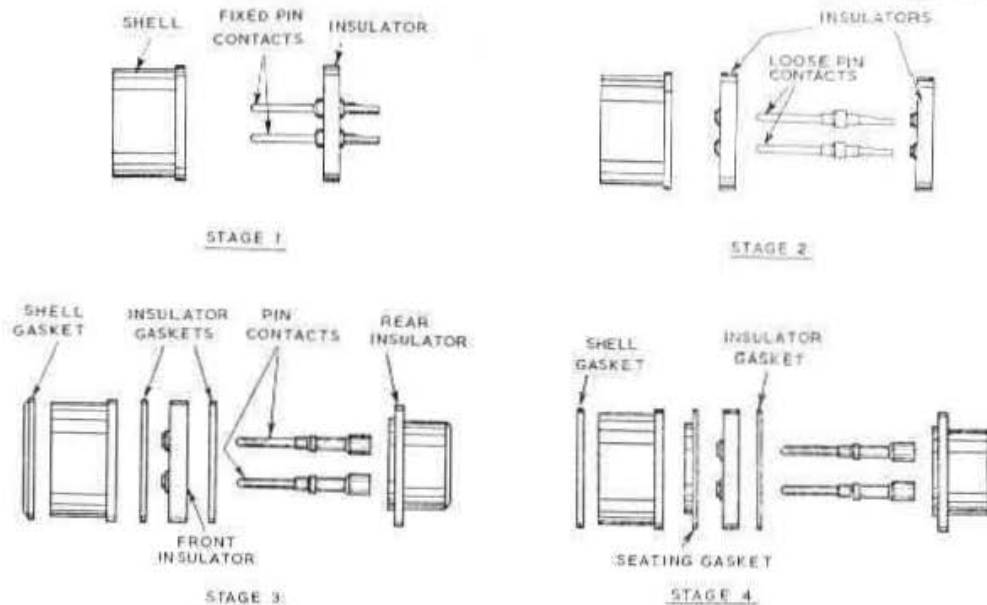

Fig. 5. Fixed unit, stages of development

Normal or reverse free unit (Tables 2, 3, 7 and 8)

Stage 1

13. This style of unit (fig. 8) was the original design, manufactured with rimmed shells in aluminium, brass or steel. It includes a long socket insulator of phenolic material and a pressed comb. Solid end split type socket contacts with short wells (suitable only for soldering) are used and these are protected by an insulating sleeve at the well ends. A diamond knurled coupling nut screws on to the back of the shell to secure the assembly; at the front of the shell the insulator is retained by an insulating ring and a circlip.

Stage 2

14. In this style (fig. 8) the shell and coupling nut were modified. The shell rim is castellated and longer shells are used in sizes D, E and F. The coupling nut is not knurled but castellated. A shortened socket insulator is used and this is backed by a comb insulator in place of the pressed comb. Rolled type socket contacts (suitable for soldering or crimping with the use of thimbles) are used and these are protected by insulating sleeves at the well ends (one sleeve is used in a size A, Z, B or C shell; two sleeves are used in a size D, E or F shell). The insulator is retained by the insulating ring at the front and a circlip at the back. The coupling nut screws on to the back of the shell to secure the assembly.

Stage 3 (climatic-proof version)

15. Units at stage 3 (fig. 6 and 8) differed from those at stage 2 in that the shell rim and the coupling nut have straight knurls. The use of a comb insulator in this type restricts the use of the unit to

arrangements of 7A and 19A contacts only. The shell length is the same as at stage 1 and a single insulating sleeve is used. A ferrule gasket has been introduced between the coupling nut and the circlip at the back, and a sealing gasket fits on to the front of the shell rim.

Stage 4 (vibration-proof version)

16. Units at stage 4 (fig. 7 and 8) introduced vibration-proof socket contacts (suitable for soldering or crimping without the use of thimbles). A pressed comb replaces the comb insulator used at stage 3, making the unit suitable for use with arrangements which include 37A and 64A contacts. Wire locking holes are drilled in the coupling nut as an added precaution against vibration.

Stage 5 (improved contacts version)

17. Units at stage 5 (fig. 8) differed only in the type of contact used. These contacts are an improved type using circlips and were designed to provide lighter insertion loading and greater contact length.

Stage 6 (uprated version)

18. Units at this stage (fig. 8) were designed to operate between ambient temperatures of -65 degrees C. and $+150$ degrees C. They are similar in construction to those in stage 5 except that the socket and comb insulators are of alkyd, and the shorter insulating sleeve and the insulating ring are of fibreglass (P.T.F.E. coated); the ferrule gasket is of silicone rubber. A steel thrust ring has been introduced at the rear of the insulating sleeve. The sealing gasket is not included in the assembly but always accompanies the unit since it may be required to mate with an early type of fixed unit.

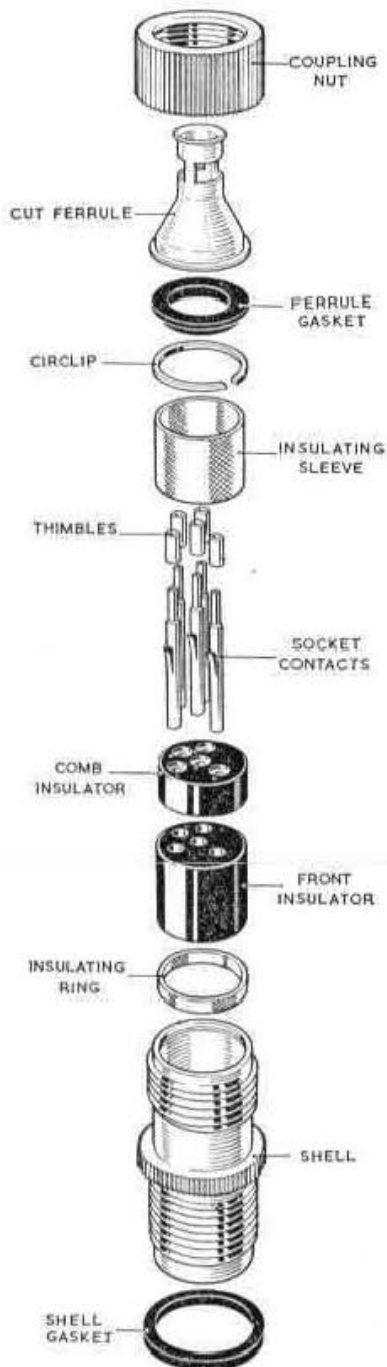

Fig. 6. Free unit (exploded) with coupling nut and cut ferrule, climatic-proof

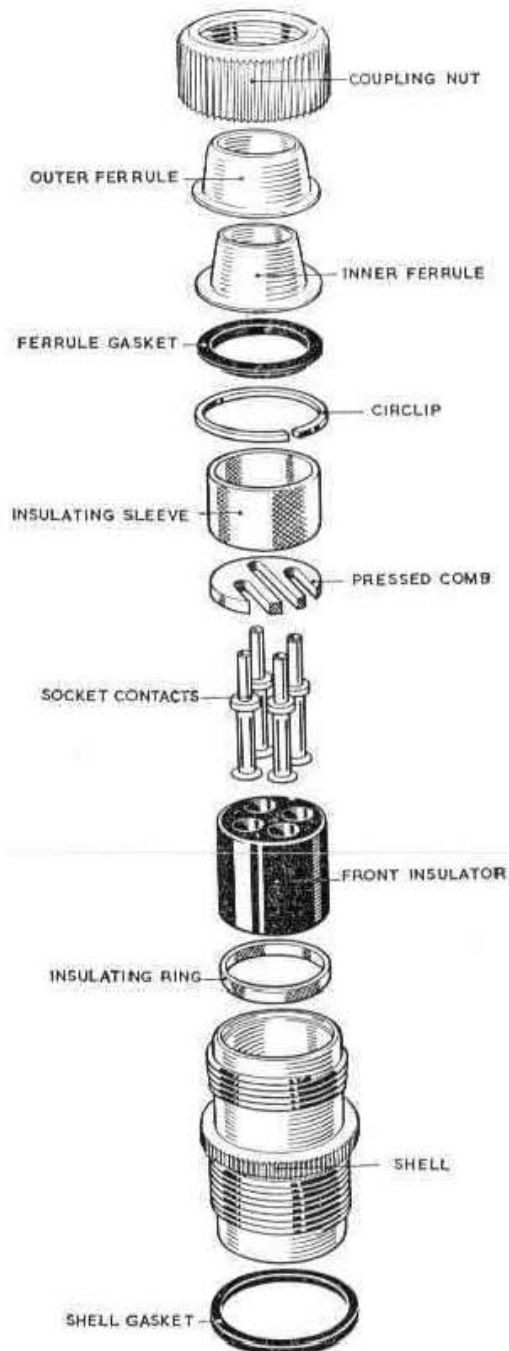

Fig. 7. Free unit (exploded) with coupling nut and inner and outer ferrules, vibration proof

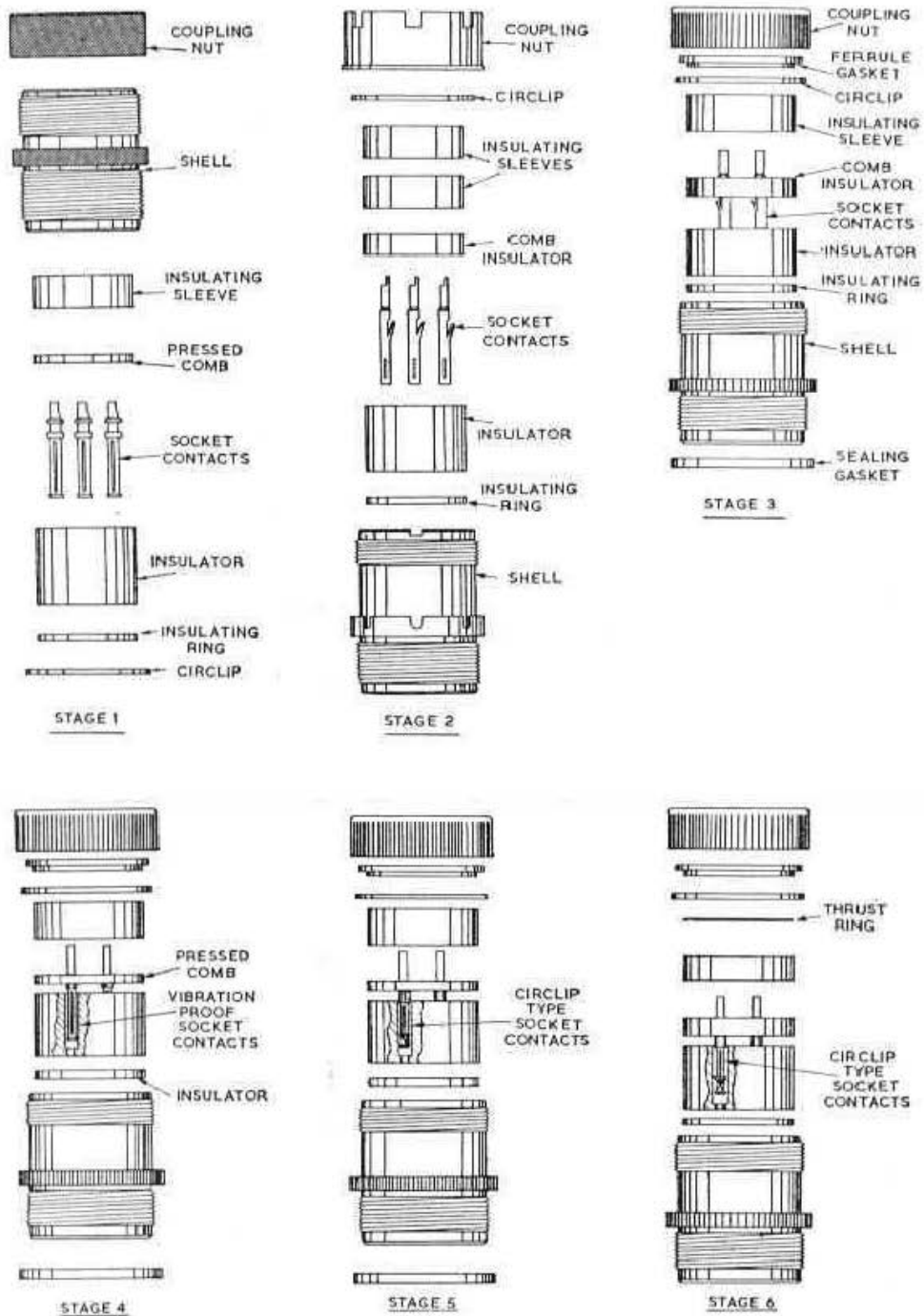

Fig. 8. Free unit, stages of development

Stage 7 (improved fluid resistant version)

19. In this version the ferrule gasket is made of asbestos fibre, thus giving the unit improved resistance to fluids and fire. These units are waterproof and vibration-proof when assembled in aluminium shells and waterproof, fireproof and vibration-proof when assembled in steel shells (para. 2(1) and 2(2)).

Bulkhead unit (Tables 4 and 9)

Stage 1 (fixed pins version)

20. This style of unit (fig. 10) was the original design and was manufactured with aluminium, brass and steel shells. In effect, the stage 1 bulkhead unit consists of two stage 1 fixed units joined back-to-back but with a single insulator (of phenolic material) in which special double-ended pins are moulded in position. It is used to connect two free units, one a normal unit, the other a reverse unit, on either side of a bulkhead (that is, the free units are mirror images of one another but otherwise identical).

Stage 2 (loose pins version)

21. This version (fig. 10) differed from stage 1 in that the insulation was formed of two identical components, each having stepped creepage barriers at the perimeters of the contact holes (para. 8). The bases of the pins are sandwiched between the insulators when the flange is secured by the fixing bolts and nuts.

Stage 3 (climatic-proof version)

22. In the stage 3 version (fig. 9 and 10), two rubber insulator gaskets (each on the pin face of the insulators) and a shell gasket were introduced to make the unit climatic-proof.

Stage 4 (uprated version)

23. In the stage 4 version (fig. 10), the front and rear insulator discs were alkyd and the shell gasket silicone rubber. A seating and a reverse seating gasket (designed to accept the leading edges of mating socket units) replace the insulator gaskets of units in stage 3 and these are also of silicone rubber. The changes leading to this stage enabled the unit to operate between ambient temperatures of -65 degrees C. and $+150$ degrees C.

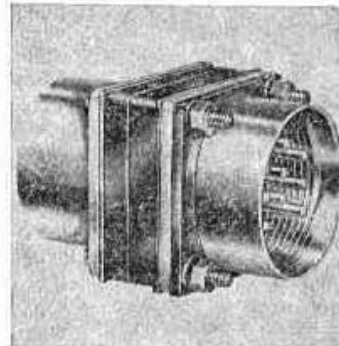

Fig. 9. Bulkhead unit, climatic-proof

Stage 5 (improved fluid-resistant version)

24. Units at this stage differ from those at stage 4 in that the shell gaskets are replaced by similar gaskets of asbestos fibre. This change improves resistance to fluids and fire. These units are waterproof and vibration-proof when assembled in aluminium shells, and waterproof, fireproof and vibration-proof when assembled in steel shells (para. 2(1) and 2(2)).

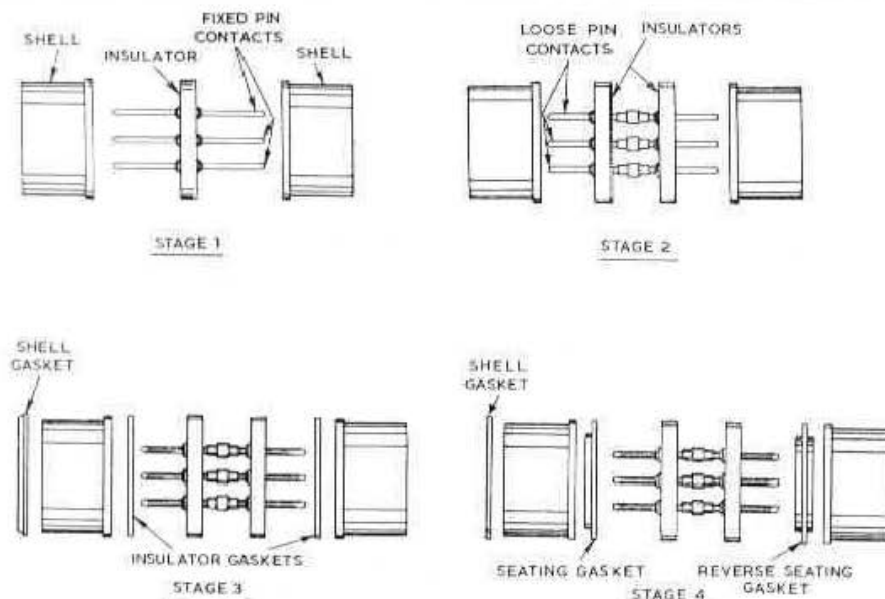

Fig. 10. Bulkhead unit, stages of development

Pressurized bulkhead unit (Table 5)
Stage 1 (original version)

25. This style of unit (fig. 11 and 12) was manufactured in aluminium and differs from the normal type bulkhead unit in that it has a round flange integral with the shell. The shell is strengthened and contains two identical insulator discs of phenolic material bonded together by sealing compound with the double-ended pins moulded in position. A sealing gasket is fitted between the insulator and the shell. Completing the sealing requirement is a mounting gasket fitting in a recess of the front face of the flange and a unit cover fitting against the rear face of the flange. Fixing bolts and nuts (four for sizes A and Z; eight for sizes B, C, D and E) hold the unit together and secure the unit to a bulkhead. The unit is proof against a pressure of 15 lb/in² but is not suitable for use in temperatures exceeding 85 degrees C. (para. 2(3)).

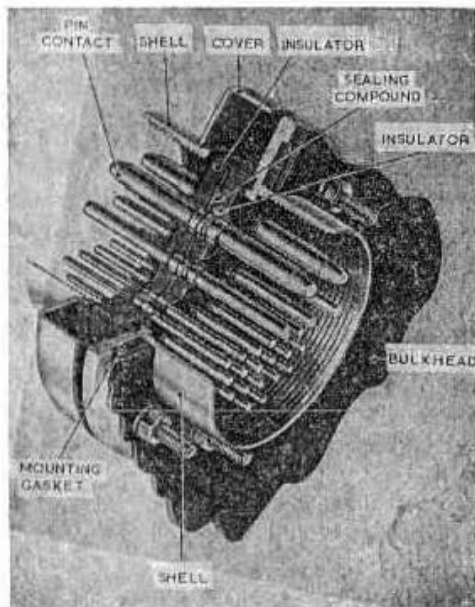

Fig. 11. Pressurised bulkhead unit

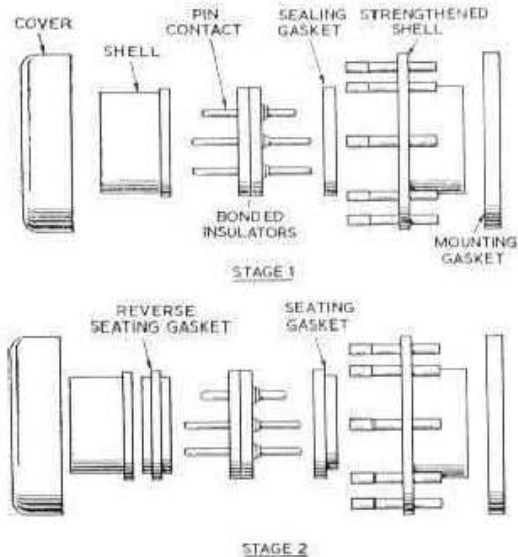

Fig. 12. Pressurised bulkhead unit, stages of development

Stage 2 and subsequent stages (uprated version)

26. Units at these stages differ from those at stage 1 in that the insulators are of alkyd; the seating and the reverse seating gaskets (designed to accept the leading edges of mating socket units) are of silicone rubber.

Special purpose connectors

Fixed unit (detachable leads) (Table 10)
Stage 1

27. This style of unit (fig. 13) was manufactured in a size A aluminium shell only for use on electric motors and other equipment where short leads only can be accommodated. In this unit the insulator holes are slotted so as to allow the pins to be slid through the widest parts of the slots. The pins are therefore removable from the insulator so that they can be more easily wired, re-inserted and subsequently withdrawn (when required) with the conductors still attached. The pins are suitable for soldering only.

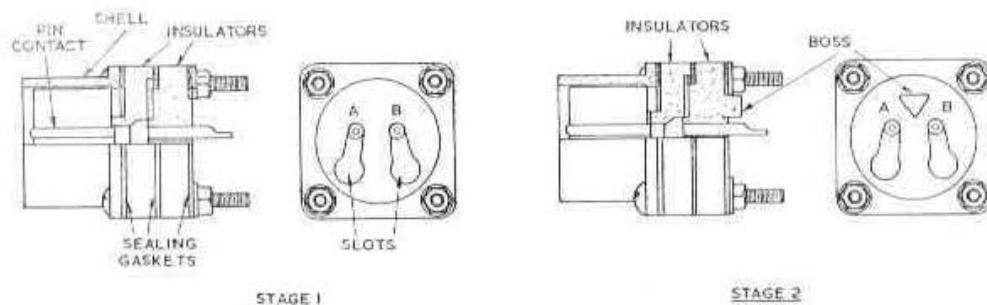

Fig. 13. Fixed unit (detachable leads), stages of development

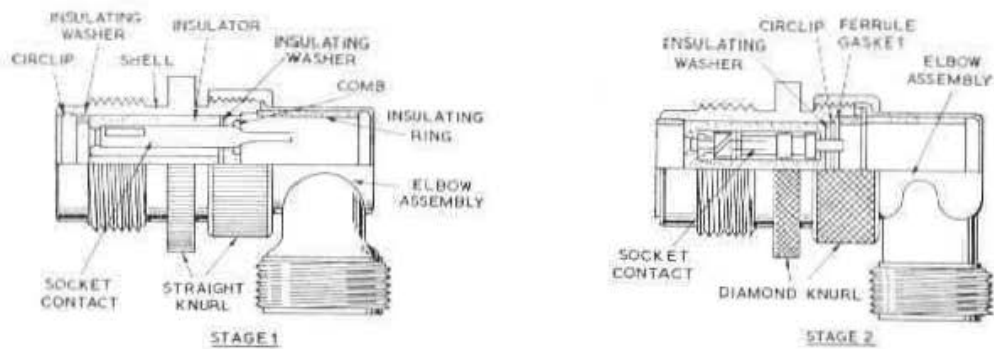

Fig. 14. Free unit (short reach), stages of development

Stage 2

28. In this version the rear insulator was modified to form a boss between the contact wells. Also, shells became available in both aluminium and steel.

Stage 3

29. Units at this stage differ from those at stage 2 only in the design of the front sealing gasket.

Free unit (short-reach) (Table 11)

Stage 1

30. This style of unit (fig. 14) was manufactured in aluminium only and differs from the normal free unit (at stage 1) in that the rear of the shell is shorter and accommodates a brass elbow outlet fitting with a dull nickel-plated finish. The unit was designed to be easily withdrawn where space is limited. Other differences are as follows:—the insulating sleeve is replaced by an insulating ring; the long insulator is of bakelite and contains rolled type contacts; the coupling nut and the shell rim have a straight knurl.

Stage 2

31. Improved circlip-type socket contacts were introduced.

Stage 3

32. Units at this stage (fig. 14) are available with aluminium or steel shells and differ from those at stage 2 in that the elbow assembly is modified; the insulator is shorter and together with the comb insulator are of alkyd; the ferrule gasket and the insulating rings are of silicone rubber. This style of unit is designed to operate between ambient temperatures of -65 degrees C. and $+150$ degrees C. The sealing gasket is not included in the assembly but is supplied with the unit in case it should be required (viz. when the unit is mated with an early type of fixed unit).

Heavy duty pressurized bulkhead connector block (Table 12)

33. This connector (fig. 15) is pressurized at 15 lb/in^2 and designed for use at pressure cabin bulkheads where heavy duty connections must be broken. The type illustrated will accommodate two 200A conductors and one 19A conductor; another

type will accommodate three 200A conductors. All conductors may be crimped or soldered to lugs mounted on the connector terminal studs. (The 19A conductor lug is a circular ferrule type and fits into a socket mounted on the terminal stud.) End covers are supplied with these units when ordered.

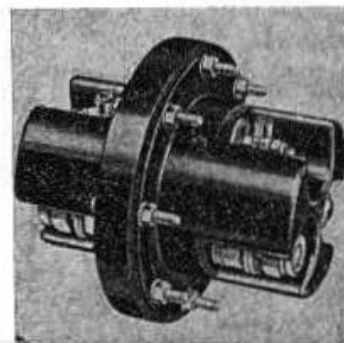

Fig. 15. Heavy duty pressurized bulkhead unit

Quick-release connector (Table 13)

Stage 1

34. Quick-release fixed and free units (fig. 16) with aluminium shells were introduced for use where rapid mating or demating was necessary. The free unit shell is not threaded but machined with an external circumferential groove; the fixed unit is fitted with four steel balls retained by a flat spring, a rubber band or a special retainer. Mating is effected when the four balls of the fixed unit lodge in the groove of the free unit; demating occurs quickly when the balls are dislodged on pulling the free unit away. When not in use the contacts are protected by a spring-loaded cap which fits over the front of the unit.

Stage 2

35. Units introduced at this stage (fig. 16) were manufactured only in steel. The quick-release principle was modified thus: four slots are machined in the fixed unit shell to accept four flat springs which are fitted to the free unit and held by a retaining ring. The insulators of both units were

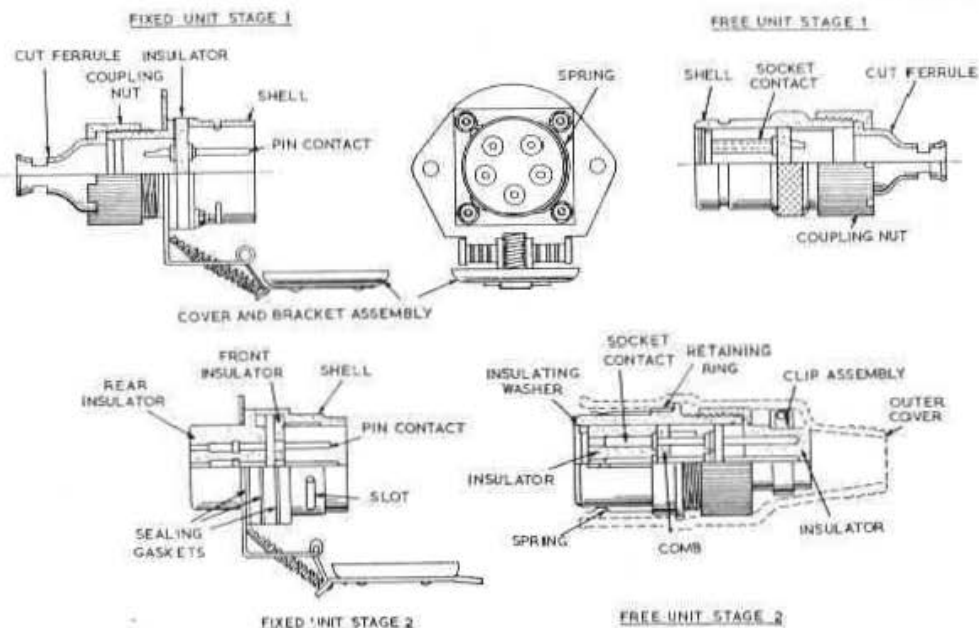

Fig. 16. Quick release fixed and free units, stages of development

extended and redesigned to accept modified pin or vibration-proof socket contacts suitable for soldered or crimped connections. An additional insulator, retained by a clip assembly, was introduced. A synthetic rubber outer cover for use on the free unit was supplied separately.

Stage 3

36. At this stage, the design of the springs on the free unit was improved and the retaining ring staged on to each spring.

Thermocouple connectors

37. A range of these units with limited contact arrangements (para. 57) is available for use in circuits employing temperature compensating leads. Part numbers of these units are listed in Table 14 which also gives details of the thermocouple contacts (para. 39).

Contacts

38. The seven sizes of contacts (7A, 7A special, 19A, 19A special, 37A, 64A and 200A) used in standard connectors have also undergone stage-by-stage development consistent with that of the connectors. The socket contacts are illustrated with their part numbers in Table 15, which also specifies those that can be used in the different stages of the free unit in relation to their sizes as well as those that may be in existence but are now superseded. The part numbers for pin contacts used in fixed and bulkhead units are also given in Table 15. All contacts are of brass, silver-plated and give electrical connections with contact resistances less than 2 milliohms for currents less than 10A and 1 milliohm for currents greater than 10A.

Thermocouple contacts (Table 14)

39. A special range of thermocouple contacts is provided for use with thermocouple fixed and free units (para. 37). These contacts are available in brass, alumel, chromel or constantan and are identified by a band of coloured paint within which there is a series of grooves (the contact position is identified on the insulator by a similar colour code). It is recommended that thermocouple contacts be soldered even if they are of a design that permits crimping.

Connector accessories

Fixed unit sealing cap (Table 25)

40. This cap is of bakelite and is designed to prevent the ingress of dust or moisture when the unit is not in use.

Fixed unit screening cap (Table 26)

41. This cap is of aluminium and may be used as an alternative to the bakelite type.

Coupling nut (Table 27, fig. 6 and 7)

42. The coupling nut is made in aluminium or steel and designed for use with free units, fixed unit shrouds, elbow or tee assemblies and for clamping all forms of cable fittings into position.

Fixed unit shroud (Table 28)

43. These shrouds are made in aluminium or steel and designed for mounting at the rear of fixed units for the purpose of attaching other cable fittings (para. 42, 46, 47, 48, 50 and 52). The four holes in the base correspond to those in the fixed unit.

Ferrule plate assembly (Table 29)

44. This assembly is made of brass with an electro-tin finish (exceptions are part numbers CZ.24634 and CZ.24640 which are dull nickel-plated) and is designed for use with plastic tubing where cables enter a panel or a junction box. The 4 fixing holes and the spigot on the front face are designed for the same panel piercing arrangements as for a fixed unit of the same size.

Clamp ring (Table 30)

45. The clamp ring is designed for clamping plastic tubing to a ferrule or to a ferrule plate assembly. There are two types, viz. a solid cadmium-plated brass ring (plain type); and an open cadmium-plated steel ring (screw type), the ends of which are drilled and tapped and fitted with a screw.

Inner and outer ferrules (Table 31 and fig. 7)

46. These ferrules are brass (nickel plated) and designed to form a sound joint when using plastic tubing, loose braid or conduit. They may be used on a free unit or on a fixed unit shroud with a coupling nut.

Ferrule for plastic tubing (Table 32)

47. This ferrule is brass (electro-tinned) and designed for use with plastic tubing and a clamp ring (para. 45). The ferrule is available standard or oversize and may be used on a free unit or on a fixed unit shroud with a coupling nut.

Conduit ferrule (Type H) (Table 33)

48. This ferrule is available in aluminium or brass (nickel-plated) and is designed for use with a metal conduit to which it is swaged or soldered. It may also be used on a free unit or on a fixed unit shroud with a coupling nut.

Conduit ferrule (Type G) (Table 34)

49. This ferrule is available in aluminium or brass (nickel-plated) and designed for use with a metal conduit to which it is swaged or soldered.

Elbow assembly (Table 35)

50. This assembly is of brass (nickel-plated) and designed to allow a right-angle entry into the rear of a free unit or into the rear of a fixed unit to which is fitted a fixed unit shroud (para. 43). Both ends of the elbow assembly are designed to accept ferrules and coupling nuts.

Tee connector (Table 36)

51. This connector is of brass (nickel-plated) and designed for use with metal conduit where take-off conductors are required at right-angles to the existing run. The three ends of the tee connector are designed to accept ferrules and coupling nuts.

Cut ferrule (round base) (Table 37 and fig. 6)

52. This ferrule is brass (nickel-plated) and designed for use with single or multi-core cables where a clamp is required immediately behind the free unit or the fixed unit shroud. Its purpose is to prevent strain on the cables being transmitted to the contacts.

Cut ferrule (square base) (Table 38)

53. This ferrule is of brass (nickel-plated) and is designed for use where single or multi-core cables are required to be clamped immediately behind a fixed unit or where cables are to be clamped on entering a junction box. The four fixing holes in the square base correspond to those of the fixed unit.

Fixed unit strainer

54. The fixed unit strainer has been designed to prevent the separation of a mated pair due to the weight of cable, etc. It consists of a rectangular plate cut so that two opposite sides are extended in the form of tags; the centre of the plate is cut out in order to fit the rear of the fixed unit. When fitted to a mated pair the tags are bent down and tied to the free unit cable.

Water sealing glands

55. A range of special water-sealing glands has been designed for fitting at the rear of connectors to prevent the ingress of moisture at the cable entries.

Spare and replacements

56. A list of available spares and replacements is given in Table 24 which also gives the materials of the items and their part numbers.

Contact arrangements

57. Twenty three different contact arrangements are available in the six shell sizes for contacts having current ratings of 7A, 7A (special), 19A, 37A and 64A. The contact arrangements possible in each of the shell sizes (specified as A, Z, B, C, D and E) are shown in fig. 20. Note: early stage units may have contact arrangements which include 17A (special) and 200A contacts (para. 38 and Tables 1 to 13).

Instructions for use

Preparations

Part numbers—shell style

58. Determine the part number for the available (viz. current) shell style from Tables 1 to 14, viz. fixed unit, bulkhead unit, normal or reverse free unit, or special purpose unit (select the unit according to the stage that gives a waterproof and vibration-proof type; a waterproof, fireproof and vibration-proof type; or a pressurized bulkhead type).

Part numbers—connector accessories

59. When connector accessories are to be fitted, select the types suitable and order them under the part numbers given in Tables 25 to 38.

Part numbers—contacts

60. Where contacts are ordered separately, order these from the part numbers given in Table 15.

Crimping tools

61. An approved crimping tool will be required. Until amended instructions are received, use:—

- (1) Buchanan Crimping Tool (MS. 3191—4—single indent type—Ref. No. 1H/279). (The appropriate locators must be available.)
- (2) Kit Crimping Plessey Ref. No. 1H/5807066.

*Wiring connectors**Cable preparation—single conductors*

62. Cut the conductors to the length required. Taking care that no strands are severed in the process, strip the insulation to a suitable length to expose the bare conductors.

Cable preparation—multi-core cables

63. Strip the outer insulation and cut the conductors to length. Then proceed as in para. 62. When wiring to a panel, crossing of conductors cannot always be avoided. Careful trimming to length of each conductor is necessary (particularly when an elbow assembly or a tee connector is to be used) to

allow the contacts to seat evenly in their correct positions in the insulator. One recommended method is to prepare a drilled plate through which the conductors can be fed in their correct positions for wiring; they may then be cut evenly to the correct lengths.

Cable preparation—screened cables

64. Cut the screened cable to length (fig. 18(A)). Strip the braid to a suitable length and wind five turns of 33 s.w.g. tinned copper wire some distance from the end (fig. 18(B)); lightly solder the wire to the braiding, taking care not to damage the cable insulation. Trim the braid so that no sharp ends or frays are left (fig. 18(C)).

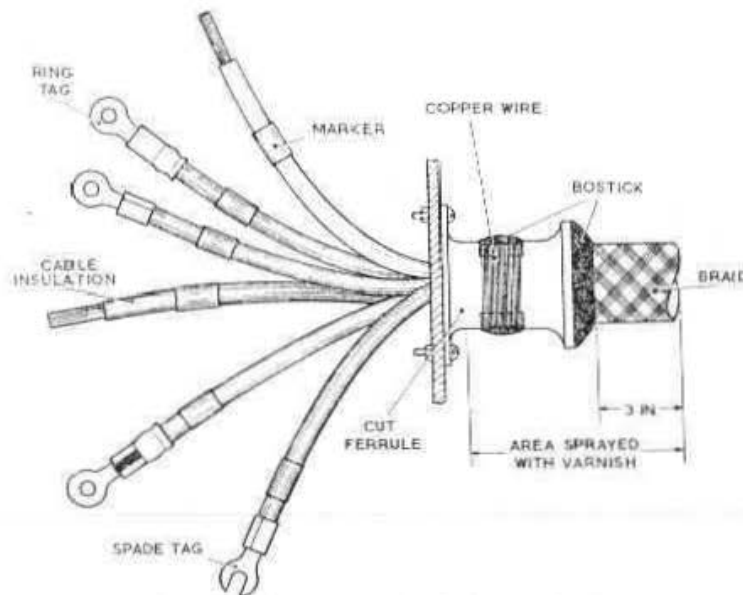

Fig. 17. Cut ferrule used with screened cable

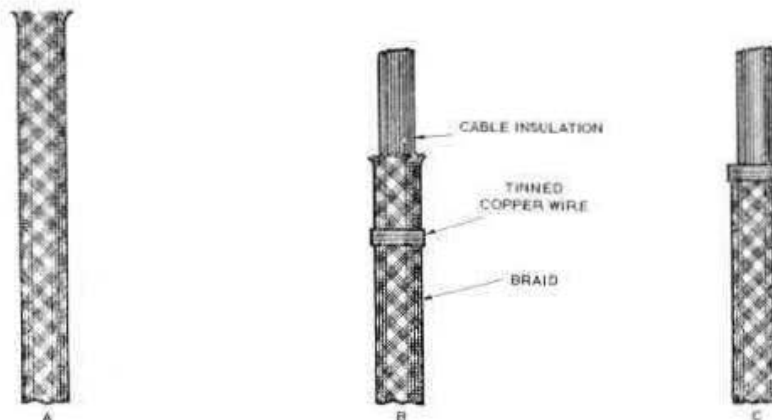

Fig. 18. Preparation of ends of screened cable

Crimping

65. Fit marker sleeves, if required, to the conductors. Fit each contact over the bared conductor end, ensuring that all strands enter the conductor well, to the full depth. Crimp the contacts to the conductors, using the instructions supplied with the tool in use.

Soldering

66. Tin dip the conductor ends and lightly tin the conductor wells with solder (to BS.219). Insert each conductor into the conductor well and solder firmly in position. Care must be taken to ensure that there is no overflow of solder from the joint and that the contact plating is not damaged by excessive heat.

Assembly of cable fittings

Cut ferrule (round or square base)—assembled to connector

67. Pass the cable through a split sleeve of the correct size, prepare the cable as for single conductors (para. 62) or for multi-core cables (para. 63), crimp or solder the conductors to the contacts (para. 65 or 66) and insert the contacts in the insulator. Locate the ferrule on the free unit or on the fixed unit shroud, pull the sleeve over the ferrule and bind with twine; coat the twine with shellac varnish.

Cut ferrule (square base)—assembled to junction box

68. Where the cut ferrule is bolted to the side of a junction box (no connector used), pass the cable through a split sleeve and through the cut ferrule into the junction box. Prepare the conductor ends with markers and suitable terminations (ring or spade type tags) depending on the terminal block in the junction box. With an unscreened cable, secure the cable in the ferrule by a few turns of waxed thread; with a screened cable secure the screen of the cable in the same way but with copper wire and solder the wire to the screen and the cut ferrule. Pull the sleeve over the ferrule and bind with twine; coat the twine with shellac varnish. An alternative method (where no split sleeve is used) is to seal the mouth and the slots of the cut ferrule with bostik and spray the area shown in fig. 17 with two coats of insulating varnish.

Inner and outer ferrules

69. Strip the PVC cover or the screen to a suitable length thus exposing the conductors. Thread the coupling nut and outer ferrule on to the PVC-covered or screened cable. Locate the inner ferrule between the conductors and the PVC cover or the screen. Prepare the conductors (para. 63 or 64) and crimp or solder the contacts to the conductor ends (para. 65 or 66) and insert the contacts in the insulator. Slide the outer ferrule down so that the PVC cover or the screen is squeezed between the two ferrules; retain the assembly by screwing home the coupling nut on the free unit or the fixed unit shroud.

Ferrule plate assembly

70. Where a ferrule plate assembly has been bolted to a panel or to the side of a junction box, first thread a plain or a screw type clamp ring on to the cable, then thread the cable through the ferrule. Prepare the conductor ends with suitable terminations depending on the terminal block behind the panel or in the junction box. Secure the cable with the plain or the screw type clamp ring.

Ferrule for plastic tubing

71. Strip the plastic tubing to a suitable length, thus exposing the cable. Thread a coupling nut and a ferrule over the plastic tubing (the circular flange towards the free unit or the fixed unit shroud). Prepare the cable and the conductors (para. 63) and crimp or solder the contacts to the conductor ends (para. 65 or 66) and insert the contacts in the insulator. Bring down the ferrule so that its flange rests against the rear of the free unit or the fixed unit shroud; retain the assembly by screwing home the coupling nut.

Conduit ferrule (Type H)

72. Thread the coupling nut and the ferrule on to the conduit (circular flange towards rear of the free unit or the fixed unit shroud). Prepare the cable and the conductors (para. 63) and crimp or solder the contacts to the conductor ends (para. 65 or 66) and insert the contacts in the insulator. Arrange the ferrule so that its flange rests against the rear of the free unit or the fixed unit shroud; retain the assembly by screwing home the coupling nut. Swage or solder the ferrule to the conduit.

Conduit ferrule (Type G)

73. Where conduit requires to be suitably terminated, thread a type G ferrule on to a cable that is cut and suitably prepared. Bring the ferrule up to the conduit and swage or solder it in position.

Fixed unit shroud

74. Where it is required to accommodate cable entry accessories to a fixed unit, a fixed unit shroud must be used. Fit the shroud to the rear of the fixed unit; prepare the cable and conductors (para. 63 or 64) and crimp or solder the contacts to the conductor ends (para. 65 or 66) and insert the contacts in the insulator. Fit the accessory in the manner described in para. 67, 69, 71, 72 or 75.

Elbow assembly

75. Thread the elbow assembly—viz. cable coupling nut, cable ferrule or ferrules, elbow fitting and the unit coupling nut, unit ferrule or ferrules on to the cable in that order. Prepare the cable and conductors (para. 63 or 64) and crimp or solder the contacts to the conductor ends (para. 65 or 66) and insert the contacts in the insulator. Arrange the cable ferrule or ferrules so that their flanges rest against the rear end of the elbow fitting and secure them by screwing home the cable coupling nut. Arrange the unit ferrule or ferrules

so that their flanges rest against the rear end of the elbow fitting and secure them by screwing home the cable coupling nut.

Tee connector assembly

76. Thread one of the cable coupling nuts, the cable ferrule or ferrules of the assembly on to the cable; follow with the tee connector fitting and arrange that the cable comes out of the fitting at right-angles to its input. Thread the second coupling nut, ferrule or ferrules on to this outgoing cable. Arrange that the take-off cable goes out of the remaining aperture of the tee connector and on to this cable. Thread the remaining cable coupling nut, the cable ferrule or ferrules of the assembly. Arrange the cable ferrules so that their flanges rest against the input, output and take-off apertures of the tee connector and secure them by screwing home the cable coupling nuts.

Ejector tool (fig. 19)

77. This tool is essential when removing type A contacts (Table 15) from insulators. Reference and part numbers of ejector tools to fit contacts sized 7A, 7A (special), 19A, 37A and 64A are given in Table 39. The tool is operated as follows:—

- (1) Place the tool end over the contacts so that it presses the contact flap back (fig. 19(A)).
- (2) Push the plunger down and eject the contact from the insulator (fig. 19(B)).

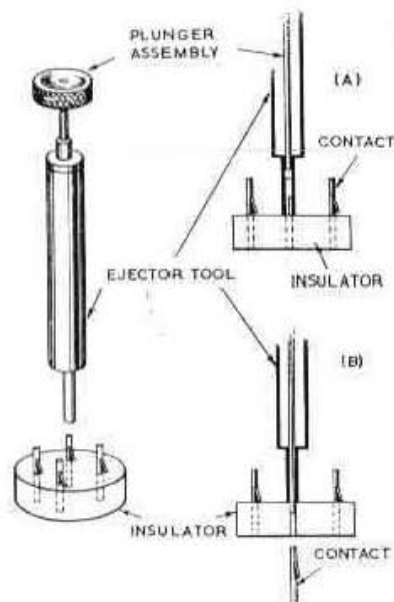

Fig. 19. Ejector tool

Renewing cables

78. When renewing a cable, use the old cable (if in a conduit) as a draw-wire for the new cable after first removing old wire ends from any bunching sleeves that may be fitted.

Issued Dec. 67

(97001)

Renewing a cable to a climatic-proof free unit

79. Work is minimized if this procedure is followed:—

- (1) Disconnect the free and fixed units.
- (2) Unscrew the coupling nut of the free unit and slide back the nut, ferrule and washer, as far as possible along the cable. If a cut ferrule is used, first cut away the binding.
- (3) Working from the front end insert the ejector tool in the relevant hole in the insulator and eject the contact (para. 77).
- (4) Pull the conductor end clear of the free unit.
- (5) Prepare the new cable and conductors (para. 62, 63 or 64) and crimp or solder the conductor ends to the new contacts.
- (6) Push the new contact into the vacant hole in the comb insulator until the contact locks into position.
- (7) Repeat (6) for all the contacts in the insulator.
- (8) Re-assemble the free unit and re-make the ferrule connection.

Renewing a cable to a vibration-proof free unit

80. Proceed as in para. 79 as far as sub-para (2); then:

- (1) Remove the circlip and inner ferrule.
- (2) Push up the insulator sufficiently to permit the comb insulator to slide clear.
- (3) Proceed as para. 79 sub-para. (3) to (8).

Mounting connectors

81. The panel piercing details for mounting fixed and bulkhead units are given in Table 16 or 17; the panel piercing details for mounting pressurised bulkhead units and heavy duty pressure proof bulkhead units are given in Tables 18 and 19 respectively; the panel piercing details for quick-release units are given in Table 20. These Tables also give the recommended distances between the centres of similar size units.

Mating connectors

Normal types

82. Slacken the free unit coupling nut (this allows the free unit shell to be rotated without twisting the cable). Line up the socket contacts with the pin contacts, then screw the free unit shell firmly into the fixed unit shell. When mating is complete, firmly tighten the coupling nut. To demate the units, first slacken the coupling nut, then unscrew the free unit shell from out of the fixed unit shell.

Quick-release types

83. To mate the units, simply push the free unit into the fixed unit. Demate the units by pulling the free unit out of the fixed unit.

WARNING

Strap wrenches must not be used for tightening connections. If necessary, they may be used with care to release a stubborn coupling nut or a screw clamp.

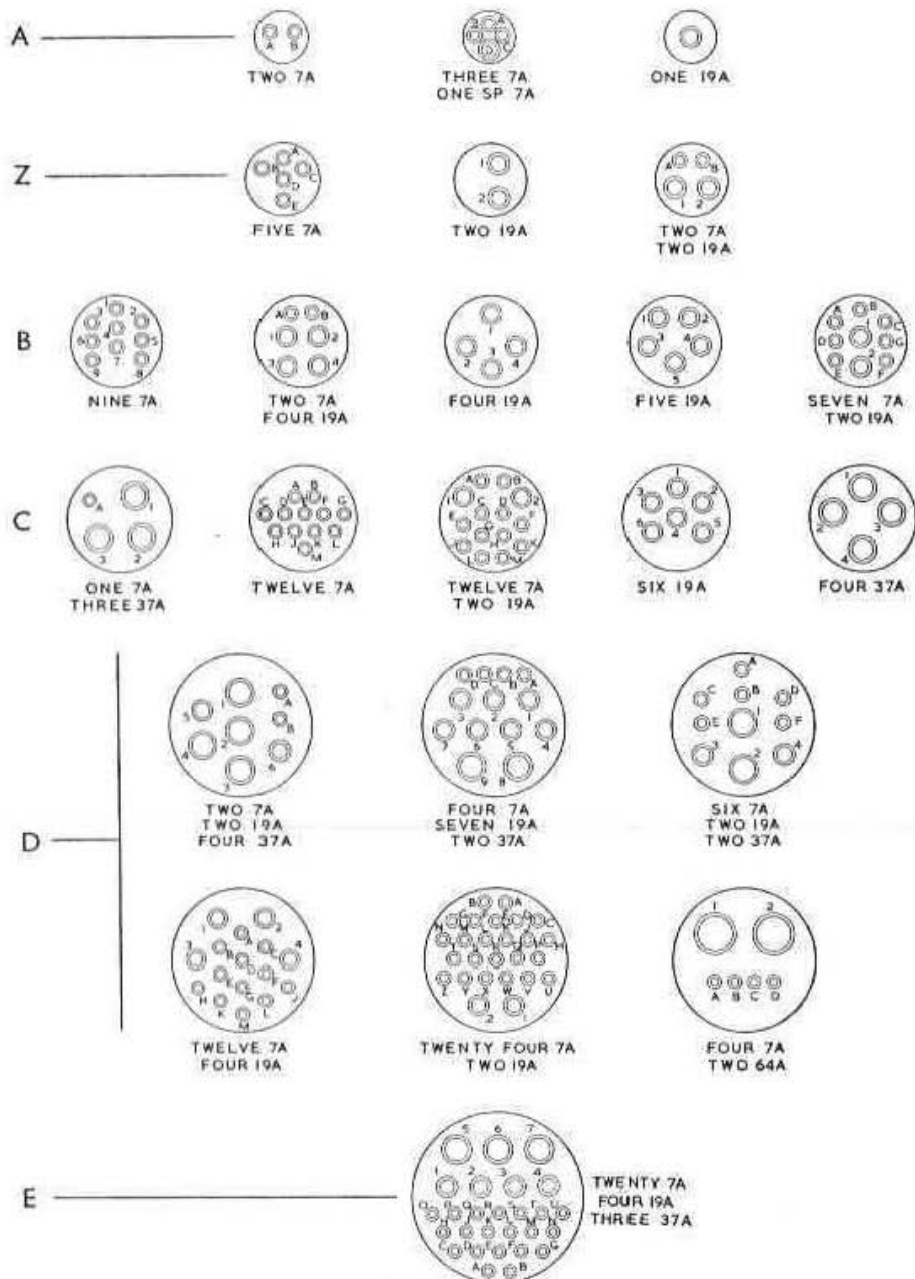

CONTACT ARRANGEMENTS
ALL VIEWS ARE LOOKING INTO THE FRONT FACE OF A PIN INSULATOR

Fig. 20. Contact arrangements

TABLE 1
Fixed Unit (Aluminium fig. 5)

Shell size	Contacts						Part No.	Ref. No.	Part No.	Ref. No.	Part No.	Ref. No.	Part No.	Ref. No.	Part No.	Ref. No.	Part No.	Ref. No.
	7	19	37	64	7sp	19sp												
A	2	—	—	—	—	—	CZ.1064	5X/1	CZ.1064/2	5X/4001	CZ.50354	5X/6326	—	—	2CZ.111223	5X/7139	508/1/06393	5X/9165
	3	—	—	—	—	—	CZ.1760	5X/2	CZ.1760/2	5X/4002	—	—	—	—	—	—	—	—
	3	—	—	—	1	—	CZ.1050	5X/3	CZ.1050/2	5X/4003	CZ.50355	5X/6179	—	—	2CZ.111399	5X/7140	508/1/06394	5X/9166
	—	1	—	—	—	—	CZ.2754	5X/4	CZ.2754/2	5X/4004	CZ.28092	5X/6011	—	—	2CZ.111400	5X/7141	508/1/06395	5X/9167
Z	5	—	—	—	—	—	CZ.2686	5X/5	CZ.2686/2	5X/4005	CZ.50356	5X/6181	—	—	2CZ.111401	5X/7142	508/1/06396	5X/9168
	7	—	—	—	—	—	CZ.2685	5X/6	CZ.2685/2	5X/4006	—	—	—	—	—	—	—	—
	—	2	—	—	—	—	CZ.2750	5X/7	CZ.2750/2	5X/4007	CZ.28095	5X/6026	—	—	2CZ.111402	5X/7143	508/1/06397	5X/9169
	2	2	—	—	—	—	CZ.12347	5X/8	CZ.12347/2	5X/4008	CZ.50374	5X/6327	—	—	2CZ.111403	5X/7144	508/1/06398	5X/9170
B	5	—	—	—	—	—	CZ.1765	5X/9	CZ.1765/2	5X/4009	—	—	—	—	—	—	—	—
	7	—	—	—	—	—	CZ.1060	5X/10	CZ.1060/2	5X/4010	—	—	—	—	—	—	—	—
	9	—	—	—	—	—	CZ.1776	5X/11	CZ.1776/2	5X/4011	CZ.50357	5X/6182	—	—	2CZ.111224	5X/7145	508/1/06399	5X/9171
	10	—	—	—	—	—	CZ.1770	5X/12	CZ.1770/2	5X/4012	—	—	—	—	—	—	—	—
	12	—	—	—	—	—	CZ.2655	5X/13	CZ.2655/2	5X/4013	—	—	—	—	—	—	—	—
	1	3	—	—	—	—	CZ.2097	5X/14	CZ.2097/2	5X/4014	—	—	—	—	—	—	—	—
	1	4	—	—	—	—	CZ.2678	5X/15	CZ.2678/2	5X/4015	—	—	—	—	—	—	—	—
	2	2	—	—	—	—	CZ.1065	5X/16	CZ.1065/2	5X/4016	—	—	—	—	—	—	—	—
	2	4	—	—	—	—	CZ.2687	5X/17	CZ.2687/2	5X/4017	CZ.50375	5X/6328	—	—	2CZ.111404	5X/7146	508/1/06400	5X/9172
	3	2	—	—	—	—	CZ.2664	5X/18	CZ.2664/2	5X/4018	—	—	—	—	—	—	—	—
	10	1	—	—	—	—	CZ.12348	5X/19	CZ.12348/2	5X/4019	—	—	—	—	—	—	—	—
	7	2	—	—	—	—	CZ.1051	5X/21	CZ.1051/2	5X/4021	CZ.56073	5X/6330	—	—	2CZ.111225	5X/7149	508/1/06403	5X/9175
	—	2	—	—	—	—	CZ.1066	5X/22	CZ.1066/2	5X/4022	—	—	—	—	—	—	—	—
	—	4	—	—	—	—	CZ.1070	5X/23	CZ.1070/2	5X/4023	CZ.50358	5X/6329	—	—	2CZ.111299	5X/7147	508/1/06401	5X/9173
	—	5	—	—	—	—	CZ.2682	5X/24	CZ.2682/2	5X/4024	CZ.50359	5X/6183	—	—	2CZ.111405	5X/7148	508/1/06402	5X/9174
	1	—	3	—	—	—	—	—	—	—	—	—	—	—	—	—	—	—
—	—	3	—	—	—	CZ.1061	5X/25	CZ.1061/2	5X/4025	—	—	—	—	—	—	—	—	
1	—	3	—	—	—	CZ.12384	5X/26	CZ.12384/2	5X/4026	CZ.28104	5X/6071	CZ.60492	5X/6318	2CZ.111406	5X/7150	508/1/06404	5X/9176	
3	—	3	—	—	—	CZ.2744	5X/27	CZ.2744/2	5X/4027	—	—	—	—	—	—	—	—	
5	3	—	—	—	—	CZ.1071	5X/28	CZ.1071/2	5X/4028	—	—	—	—	—	—	—	—	
6	4	—	—	—	—	CZ.2658	5X/29	CZ.2658/2	5X/4029	—	—	—	—	—	—	—	—	
7	3	—	—	—	—	CZ.1088	5X/30	CZ.1088/2	5X/4030	—	—	—	—	—	—	—	—	
10	3	—	—	—	—	CZ.12370	5X/31	CZ.12370/2	5X/4031	—	—	—	—	—	—	—	—	
12	—	—	—	—	—	CZ.2103	5X/32	CZ.2103/2	5X/4032	CZ.50360	5X/6184	—	—	2CZ.111226	5X/7151	508/1/06405	5X/9177	
12	2	—	—	—	—	CZ.1052	5X/33	CZ.1052/2	5X/4033	CZ.28108	5X/6091	—	—	2CZ.111227	5X/7152	508/1/06406	5X/9178	
16	—	—	—	—	—	CZ.1094	5X/34	CZ.1094/2	5X/4034	—	—	—	—	—	—	—	—	
—	6	—	—	—	—	CZ.1782	5X/35	CZ.1782/2	5X/4035	CZ.28109	5X/6096	—	—	2CZ.111297	5X/7153	508/1/06407	5X/9179	
—	—	4	—	—	—	—	—	CZ.50663	—	CZ.28110	5X/6101	CZ.60491	5X/6331	2CZ.111228	5X/7154	508/1/06408	5X/9180	

STAGE 1

STAGE 2

STAGE 3

STAGE 4

STAGE 5

TABLE 1 continued

Shell size	Contacts						Part No.	Ref. No.	Part No.	Ref. No.	Part No.	Ref. No.	Part No.	Ref. No.	Part No.	Ref. No.		
	7	19	37	64	7sp	19sp											200	
	2	2	4	—	—	—	CZ.2672	5X/37	CZ.2672/2	5X/4037	CZ.28111	5X/6106	CZ.60493	5X/6332	2CZ.111407	5X/7155	508/1/06409	5X/9181
	4	—	—	2	—	—	CZ.2755	5X/38	CZ.2755/2	5X/4038	CZ.56066	—	CZ.60495	5X/6335	2CZ.111411	5X/7445	508/1/06414	5X/9186
	4	6	—	—	—	—	CZ.2110	5X/39	CZ.2110/2	5X/4039	—	—	—	—	—	—	—	—
	4	7	2	—	—	—	CZ.1055	5X/40	CZ.1055/2	5X/4040	CZ.28112	5X/6111	CZ.60494	5X/6333	2CZ.111408	5X/7156	508/1/06410	5X/9182
	6	2	2	—	—	—	CZ.2757	5X/41	CZ.2757/2	5X/4041	CZ.28113	5X/6116	CZ.60496	5X/6334	2CZ.111409	5X/7157	508/1/06411	5X/9183
	7	7	2	—	—	—	CZ.2753	5X/42	CZ.2753/2	5X/4042	—	—	—	—	—	—	—	—
	8	4	—	—	—	—	CZ.2739	5X/43	CZ.2739/2	5X/4043	—	—	—	—	—	—	—	—
D	8	—	3	—	—	—	CZ.2743	5X/44	CZ.2743/2	5X/4044	—	—	—	—	—	—	—	—
	9	4	3	—	—	—	CZ.1054	5X/45	CZ.1054/2	5X/4045	—	—	—	—	—	—	—	—
	11	—	—	2	—	—	CZ.2758	5X/46	CZ.2758/2	5X/4046	—	—	—	—	—	—	—	—
	11	6	2	—	—	—	CZ.12365	5X/47	CZ.12365/2	5X/4047	—	—	—	—	—	—	—	—
	12	4	—	—	—	—	CZ.1092	5X/48	CZ.1092/2	5X/4048	CZ.28115	5X/6126	—	—	2CZ.111410	5X/7158	508/1/06412	5X/9184
	13	—	3	—	—	—	CZ.2091	5X/49	CZ.2091/2	5X/4049	—	—	—	—	—	—	—	—
	20	—	—	—	—	—	CZ.1067	5X/50	CZ.1067/2	5X/4050	—	—	—	—	—	—	—	—
	24	2	—	—	—	—	CZ.1053	5X/51	CZ.1053/2	5X/4051	CZ.50361	5X/6185	—	—	2CZ.111229	5X/7159	508/1/06413	5X/9185
	—	—	—	3	—	—	CZ.12377	5X/52	CZ.12377/2	5X/4052	—	—	—	—	—	—	—	—
	9	16	—	—	—	—	CZ.1058	5X/55	CZ.1058/2	5X/4055	—	—	—	—	—	—	—	—
	20	4	3	—	—	—	CZ.1057	5X/56	CZ.1057/2	5X/4056	CZ.50362	—	CZ.60497	5X/6336	2CZ.111412	5X/7160	508/1/06415	5X/9187
	—	—	—	—	—	1	2	CZ.2099	5X/57	—	—	—	—	—	—	—	—	—
	—	—	—	—	—	1	2	CZ.2679	5X/58	—	—	—	—	—	—	—	—	—
	—	—	—	—	—	1	2	CZ.2680	5X/59	—	—	—	—	—	—	—	—	—
	—	—	—	—	—	1	2	CZ.1072	5X/60	—	—	—	—	—	—	—	—	—
E	—	—	2	2	—	—	CZ.16568	5X/1554	CZ.16568/2	5X/5554	—	—	—	—	—	—	—	—
	—	—	—	—	—	1	2	CZ.17883	5X/198	—	—	—	—	—	—	—	—	—
	—	—	—	—	—	1	2	CZ.17884	5X/199	—	—	—	—	—	—	—	—	—
	—	—	—	—	—	1	2	CZ.18960	5X/1567	—	—	—	—	—	—	—	—	—
	—	—	—	—	—	1	2	CZ.18961	5X/1568	—	—	—	—	—	—	—	—	—
	—	—	—	—	—	1	2	CZ.12391	5X/1285	—	—	—	—	—	—	—	—	—
	—	—	—	—	—	3	3	CZ.2113	5X/61	—	—	—	—	—	—	—	—	—
	—	—	—	—	—	3	3	CZ.2752	5X/62	—	—	—	—	—	—	—	—	—
	—	—	—	—	—	3	3	CZ.17924	5X/1589	—	—	—	—	—	—	—	—	—
	—	—	—	—	—	3	3	CZ.12363	5X/64	—	—	—	—	—	—	—	—	—
F	—	—	—	—	—	3	3	CZ.19250	5X/1706	—	—	—	—	—	—	—	—	—
	—	—	—	—	—	3	3	CZ.19251	5X/1707	—	—	—	—	—	—	—	—	—
	—	—	—	—	—	3	3	CZ.19252	5X/1708	—	—	—	—	—	—	—	—	—
	—	—	—	—	—	3	3	CZ.19253	5X/1709	—	—	—	—	—	—	—	—	—
	—	—	—	—	—	3	3	CZ.12389	5X/65	—	—	—	—	—	—	—	—	—

E

STAGE 1

STAGE 2

STAGE 3

STAGE 4

STAGE 5

TABLE 2
Normal Free Unit (Aluminium fig. 8)

Shell size	Contacts						Part No.		Ref. No.		Part No.		Ref. No.		Part No.		Ref. No.		Part No.		Ref. No.					
	7	10	37	64	7sp	19sp	200																			
A	2	—	—	—	—	—	—	CZ.1114	5X/101	CZ.1114/2	5X/101	CZ.1114/3	5X/101	CZ.50398	5X/6188	—	—	CZ.56084	5X/6772	2CZ.111646	5X/6772/B	2CZ.111230	5X/7172	508/1/03941	5X/9075	
	3	—	—	—	—	—	—	CZ.1761	5X/102	CZ.1761/2	5X/102	CZ.1761/3	5X/102	CZ.55897	5X/6632	—	—	CZ.56088	5X/6799	2CZ.111647	5X/6799/B	2CZ.111231	5X/7173	508/1/03942	5X/9076	
	3	—	—	—	1	—	—	CZ.1100	5X/103	CZ.1100/2	5X/103	CZ.1100/3	5X/103	CZ.50399	5X/6189	—	—	CZ.56088	5X/6799	2CZ.111647	5X/6799/B	2CZ.111231	5X/7173	508/1/03942	5X/9076	
	—	1	—	—	—	—	—	CZ.2704	5X/104	CZ.2704/2	5X/104	CZ.2704/3	5X/104	CZ.27902	5X/6014	—	—	CZ.71748	5X/6773	2CZ.111648	5X/6773/B	2CZ.111232	5X/7174	508/1/03943	5X/9077	
Z	5	—	—	—	—	—	—	CZ.2698	5X/105	CZ.2698/2	5X/105	CZ.2698/3	5X/105	CZ.50400	5X/6190	—	—	CZ.56092	5X/6776	2CZ.111649	5X/6776/B	2CZ.111233	5X/7175	508/1/03944	5X/9078	
	7	—	—	—	—	—	—	CZ.1144	5X/106	CZ.1144/2	5X/106	CZ.1144/3	5X/106	CZ.64183	5X/6707	—	—	CZ.71749	5X/6822	2CZ.111650	5X/6822/B	2CZ.111436	5X/7176	508/1/03945	5X/9079	
	—	2	—	—	—	—	—	CZ.2702	5X/107	CZ.2702/2	5X/107	CZ.2702/3	5X/107	CZ.27905	5X/6029	—	—	CZ.71749	5X/6822	2CZ.111650	5X/6822/B	2CZ.111436	5X/7176	508/1/03945	5X/9079	
	2	2	—	—	—	—	—	CZ.10340	5X/108	CZ.10340/2	5X/108	CZ.10340/3	5X/108	CZ.50418	5X/6350	—	—	CZ.56096	5X/6775	2CZ.111651	5X/6775/B	2CZ.111437	5X/7177	508/1/03946	5X/9080	
B	5	—	—	—	—	—	—	CZ.1766	5X/109	CZ.1766/2	5X/109	CZ.1766/3	5X/109	—	—	—	—	—	—	—	—	—	—	—	—	
	7	—	—	—	—	—	—	CZ.1110	5X/110	CZ.1110/2	5X/110	CZ.1110/3	5X/110	—	—	—	—	—	—	—	—	—	—	—	—	
	9	—	—	—	—	—	—	CZ.1777	5X/111	CZ.1777/2	5X/111	CZ.1777/3	5X/111	CZ.50401	5X/6191	—	—	CZ.56100	5X/6777	2CZ.111652	5X/6777/B	2CZ.111234	5X/7178	508/1/03947	5X/9081	
	10	—	—	—	—	—	—	CZ.1771	5X/112	CZ.1771/2	5X/112	CZ.1771/3	5X/112	—	—	—	—	—	—	—	—	—	—	—	—	
	12	—	—	—	—	—	—	CZ.2135	5X/113	CZ.2135/2	5X/113	CZ.2135/3	5X/113	—	—	—	—	—	—	—	—	—	—	—	—	
	1	3	—	—	—	—	—	—	CZ.2118	5X/114	CZ.2118/2	5X/114	CZ.2118/3	5X/114	—	—	—	—	—	—	—	—	—	—	—	
	1	4	—	—	—	—	—	—	CZ.2697	5X/115	CZ.2697/2	5X/115	CZ.2697/3	5X/115	—	—	—	—	—	—	—	—	—	—	—	
	2	2	—	—	—	—	—	—	CZ.1115	5X/116	CZ.1115/2	5X/116	CZ.1115/3	5X/116	—	—	—	—	—	—	—	—	—	—	—	
	2	4	—	—	—	—	—	—	CZ.2699	5X/117	CZ.2699/2	5X/117	CZ.2699/3	5X/117	CZ.50419	5X/6351	—	—	CZ.56104	5X/6774	2CZ.111653	5X/6774/B	2CZ.111438	5X/7179	508/1/03948	5X/9082
	3	2	—	—	—	—	—	—	CZ.2695	5X/118	CZ.2695/2	5X/118	CZ.2695/3	5X/118	—	—	—	—	—	—	—	—	—	—	—	
	10	1	—	—	—	—	—	—	CZ.10343	5X/120	CZ.10343/2	5X/120	CZ.10343/3	5X/120	—	—	—	—	—	—	—	—	—	—	—	
	7	2	—	—	—	—	—	—	CZ.1101	5X/122	CZ.1101/2	5X/122	CZ.1101/3	5X/122	CZ.56074	5X/6353	—	—	CZ.71757	5X/6778	2CZ.111656	5X/6778/B	2CZ.111440	5X/7182	508/1/03951	5X/9085
	—	2	—	—	—	—	—	—	CZ.1116	5X/123	CZ.1116/2	5X/123	CZ.1116/3	5X/123	—	—	—	—	—	—	—	—	—	—	—	
—	4	—	—	—	—	—	—	CZ.1120	5X/124	CZ.1120/2	5X/124	CZ.1120/3	5X/124	CZ.50402	5X/6352	—	—	CZ.56108	5X/6779	2CZ.111654	5X/6779/B	2CZ.111298	5X/7180	508/1/03949	5X/9083	
—	5	—	—	—	—	—	—	CZ.2693	5X/125	CZ.2693/2	5X/125	CZ.2693/3	5X/125	CZ.50403	5X/6192	—	—	CZ.71750	5X/6829	2CZ.111655	5X/6829/B	2CZ.111439	5X/7181	508/1/03950	5X/9084	
1	—	3	—	—	—	—	—	CZ.1031	5X/126	CZ.1031/2	5X/126	CZ.1031/3	5X/126	—	—	—	—	—	—	—	—	—	—	—		
—	—	3	—	—	—	—	—	CZ.1111	5X/127	CZ.1111/2	5X/127	CZ.1111/3	5X/127	—	—	—	—	—	—	—	—	—	—	—		
C	1	—	3	—	—	—	—	CZ.2095	5X/128	CZ.2095/2	5X/128	CZ.2095/3	5X/128	CZ.27914	5X/6074	CZ.60522	5X/6319	CZ.71759	5X/6826	2CZ.111657	5X/6826/B	2CZ.111441	5X/7183	508/1/03952	5X/9086	
	3	—	3	—	—	—	—	CZ.2121	5X/129	CZ.2121/2	5X/129	CZ.2121/3	5X/129	—	—	—	—	—	—	—	—	—	—	—		
	5	3	—	—	—	—	—	CZ.1127	5X/130	CZ.1127/2	5X/130	CZ.1127/3	5X/130	—	—	—	—	—	—	—	—	—	—	—		
	6	4	—	—	—	—	—	CZ.2692	5X/131	CZ.2692/2	5X/131	CZ.2692/3	5X/131	—	—	—	—	—	—	—	—	—	—	—		
	7	3	—	—	—	—	—	CZ.1089	5X/132	CZ.1089/2	5X/132	CZ.1089/3	5X/132	—	—	—	—	—	—	—	—	—	—	—		
	10	3	—	—	—	—	—	CZ.10354	5X/133	CZ.10354/2	5X/133	CZ.10354/3	5X/133	—	—	—	—	—	—	—	—	—	—	—		
	12	—	—	—	—	—	—	CZ.2122	5X/134	CZ.2122/2	5X/134	CZ.2122/3	5X/134	CZ.50404	5X/6193	—	—	CZ.56112	5X/6780	2CZ.111658	5X/6780/B	2CZ.111235	5X/7184	508/1/03953	5X/9087	
	12	2	—	—	—	—	—	CZ.1102	5X/135	CZ.1102/2	5X/135	CZ.1102/3	5X/135	CZ.27918	5X/6094	—	—	CZ.71751	5X/6781	2CZ.111659	5X/6781/B	2CZ.111236	5X/7185	508/1/03954	5X/9088	
	16	—	—	—	—	—	—	CZ.1095	5X/136	CZ.1095/2	5X/136	CZ.1095/3	5X/136	—	—	—	—	—	—	—	—	—	—	—	—	
	—	6	—	—	—	—	—	—	CZ.1783	5X/137	CZ.1783/2	5X/137	CZ.1783/3	5X/137	CZ.27919	5X/6099	—	—	CZ.71752	5X/6832	2CZ.111660	5X/6832/B	2CZ.111296	5X/7186	508/1/03955	5X/9089
—	—	4	—	—	—	—	—	CZ.10349	5X/138	CZ.10349/2	5X/138	CZ.10349/3	5X/138	CZ.27920	5X/6104	CZ.60525	5X/6354	CZ.71760	5X/6798	2CZ.111661	5X/6798/B	2CZ.111237	5X/7187	508/1/03956	5X/9090	

STAGE 1 ← STAGE 2 → ← STAGE 3 → STAGE 4 STAGE 5 STAGE 6 STAGE 7

TABLE 2 continued

Page 30

GC	Shell size	Contacts					Part No.	Ref. No.	Part No.	Ref. No.	Part No.	Ref. No.	Part No.	Ref. No.	Part No.	Ref. No.	Part No.	Ref. No.	Part No.	Ref. No.				
		7	19	37	64	Tap 19p 200																		
	2	2	4	—	—	—	CZ.2696	5X/140	CZ.2696/2	5X/140	CZ.2696/3	5X/140	CZ.27921	5X/6109	CZ.60527	5X/6355	CZ.71765	5X/6813	2CZ.111663	5X/6813/B	2CZ.111442	5X/7188	508/1.03957	5X/9091
	4	—	—	2	—	—	CZ.2707	5X/141	CZ.2707/2	5X/141	CZ.2707/3	5X/141	—	—	CZ.56065	5X/6309	CZ.71755	5X/6834	2CZ.111667	5X/6834/B	2CZ.111446	5X/7634	508/1.03962	5X/9096
	4	6	—	—	—	—	CZ.2126	5X/142	CZ.2126/2	5X/142	CZ.2126/3	5X/142												
	4	7	2	—	—	—	CZ.1105	5X/143	CZ.1105/2	5X/143	CZ.1105/3	5X/143	CZ.27922	5X/6114	CZ.60529	5X/6356	CZ.71761	5X/6842	2CZ.111663	5X/6842/B	2CZ.111443	5X/7189	508/1.03958	5X/9092
	6	2	2	—	—	—	CZ.2713	5X/144	CZ.2713/2	5X/144	CZ.2713/3	5X/144	CZ.27923	5X/6119	CZ.60526	5X/6357	CZ.71762	5X/6839	2CZ.111664	5X/6839/B	2CZ.111444	5X/7190	508/1.03959	5X/9093
	7	7	2	—	—	—	CZ.2712	5X/145	CZ.2712/2	5X/145	CZ.2712/3	5X/145												
	8	4	—	—	—	—	CZ.2120	5X/146	CZ.2120/2	5X/146	CZ.2120/3	5X/146												
D	8	—	3	—	—	—	CZ.2123	5X/147	CZ.2123/2	5X/147	CZ.2123/3	5X/147												
	9	4	3	—	—	—	CZ.1104	5X/148	CZ.1104/2	5X/148	CZ.1104/3	5X/148												
	11	—	—	2	—	—	CZ.2714	5X/149	CZ.2714/2	5X/149	CZ.2714/3	5X/149												
	11	6	2	—	—	—	CZ.10352	5X/150	CZ.10352/2	5X/150	CZ.10352/3	5X/150												
	12	4	—	—	—	—	CZ.1093	5X/151	CZ.1093/2	5X/151	CZ.1093/3	5X/151	CZ.27925	5X/6129	—	—	CZ.71753	5X/6782	2CZ.111665	5X/6782/B	2CZ.111445	5X/7191	508/1.03960	5X/9094
	13	—	3	—	—	—	CZ.2113	5X/152	CZ.2113/2	5X/152	CZ.2113/3	5X/152												
	20	—	—	—	—	—	CZ.1135	5X/153	CZ.1135/2	5X/153	CZ.1135/3	5X/153												
	24	2	—	—	—	—	CZ.1103	5X/154	CZ.1103/2	5X/154	CZ.1103/3	5X/154	CZ.50405	5X/6194	—	—	CZ.71754	5X/6783	2CZ.111666	5X/6783/B	2CZ.111238	5X/7192	508/1.03961	5X/9095
	—	—	—	3	—	—	CZ.10365	5X/155	CZ.10365/2	5X/155	CZ.10365/3	5X/155												
	9	16	—	—	—	—	CZ.1108	—	CZ.1108/2	5X/158	CZ.1108/3	5X/158												
	20	4	3	—	—	—	CZ.1107	—	CZ.1107/2	5X/159	CZ.1107/3	5X/159	CZ.50406	—	CZ.60532	5X/6358	CZ.71766	5X/6845	2CZ.111668	5X/6845/B	2CZ.111447	5X/7193	508/1.03963	5X/9097
	—	—	—	—	1	2	CZ.1117	—	CZ.1117/2	5X/160														
	—	—	—	—	1	2	CZ.1117	—	CZ.1117/2	5X/160														
	—	—	—	—	1	2	CZ.1117	—	CZ.1117/2	5X/160														
	—	—	—	—	1	2	CZ.1117	—	CZ.1117/2	5X/160														
E	—	—	2	2	—	—	—	—	CZ.15155	5X/1855	CZ.15155/3	5X/1855												
	—	—	—	—	1	2	CZ.1117	—	CZ.1117/2	5X/160														
	—	—	—	—	1	2	CZ.1117	—	CZ.1117/2	5X/160														
	—	—	—	—	1	2	CZ.1117	—	CZ.1117/2	5X/160														
	—	—	—	—	1	2	CZ.1117	—	CZ.1117/2	5X/160														
	—	—	—	—	1	2	CZ.1117	—	CZ.1117/2	5X/160														
	—	—	—	—	3	3	CZ.2128	—	CZ.2128/2	5X/161														
	—	—	—	—	3	3	CZ.2128	—	CZ.2128/2	5X/161														
	—	—	—	—	3	3	CZ.2128	—	CZ.2128/2	5X/161														
	—	—	—	—	3	3	CZ.2128	—	CZ.2128/2	5X/161														
F	—	—	—	—	3	3	CZ.2128	—	CZ.2128/2	5X/161														
	—	—	—	—	3	3	CZ.2128	—	CZ.2128/2	5X/161														
	—	—	—	—	3	3	CZ.2128	—	CZ.2128/2	5X/161														
	—	—	—	—	3	3	CZ.2128	—	CZ.2128/2	5X/161														

STAGE 1 STAGE 2 STAGE 3 STAGE 4 STAGE 5 STAGE 6 STAGE 7

TABLE 3
Reverse Free Unit (Aluminium fig. 8)

Shell size	Contacts					Part No.	Ref. No.	Part No.	Ref. No.	Part No.	Ref. No.	Part No.	Ref. No.	Part No.	Ref. No.	Part No.	Ref. No.	Part No.	Ref. No.				
	7	19	37	64	7sp 19sp 200																		
A	2	—	—	—	—	CZ.1114A	—	CZ.1114A/2	—	CZ.1114A/3	5X/162	CZ.50407	5X/6290	—	—	CZ.56086	5X/6821	2CZ.111669	5X/6821/B	2CZ.111448	5X/7194	508/1/03964	5X/9098
	3	—	—	—	—	CZ.1761A	—	CZ.1761A/2	—	CZ.1761A/3	5X/163	—	—	—	—	—	—	—	—	—	—	—	—
	3	—	—	1	—	CZ.1100A	—	CZ.1100A/2	—	CZ.1100A/3	5X/164	CZ.50408	5X/6195	—	—	CZ.56090	5X/6823	2CZ.111670	5X/6823/B	2CZ.111449	5X/7195	508/1/03965	5X/9099
	—	1	—	—	—	CZ.2704	5X/104	CZ.2704/2	5X/104	CZ.2704/3	5X/104	CZ.27902	5X/6014	—	—	CZ.71748	5X/6773	2CZ.111648	5X/6773/B	2CZ.111232	5X/7174	508/1/03943	5X/9077
Z	5	—	—	—	—	CZ.2698A	—	CZ.2698A/2	—	CZ.2698A/3	5X/165	CZ.50409	5X/6196	—	—	CZ.56094	5X/6801	2CZ.111672	5X/6801/B	2CZ.111451	5X/7197	508/1/03966	5X/9100
	7	—	—	—	—	—	—	—	—	—	—	—	—	—	—	—	—	—	—	—	—	—	—
	—	2	—	—	—	CZ.2702A	—	CZ.2702A/2	—	CZ.2702A/3	5X/166	CZ.27985	5X/6030	—	—	CZ.71768	5X/6811	2CZ.111673	5X/6811/B	2CZ.111452	5X/7198	508/1/03967	5X/9101
	2	2	—	—	—	CZ.10340A	—	CZ.10340A/2	—	CZ.10340A/3	5X/167	CZ.50431	5X/6361	—	—	CZ.56098	5X/6824	2CZ.111674	5X/6824/B	2CZ.111453	5X/7199	508/1/03968	5X/9102
B	5	—	—	—	—	—	—	—	—	—	—	—	—	—	—	—	—	—	—	—	—	—	—
	7	—	—	—	—	CZ.1110A	—	CZ.1110A/2	—	CZ.1110A/3	5X/168	—	—	—	—	—	—	—	—	—	—	—	—
	9	—	—	—	—	—	—	—	—	—	—	CZ.50410	5X/6197	—	—	CZ.56102	5X/6837	2CZ.111675	5X/6837/B	2CZ.111454	5X/7200	508/1/03969	5X/9103
	10	—	—	—	—	CZ.1771A	—	CZ.1771A/2	—	CZ.1771A/3	5X/169	—	—	—	—	—	—	—	—	—	—	—	—
	12	—	—	—	—	—	—	—	—	—	—	—	—	—	—	—	—	—	—	—	—	—	—
	1	3	—	—	—	—	—	—	—	—	—	—	—	—	—	—	—	—	—	—	—	—	—
	1	4	—	—	—	—	—	—	—	—	—	—	—	—	—	—	—	—	—	—	—	—	—
	2	2	—	—	—	CZ.1115A	—	CZ.1115A/2	—	CZ.1115A/3	5X/170	—	—	—	—	—	—	—	—	—	—	—	—
	2	4	—	—	—	—	—	—	—	—	—	CZ.50432	5X/6362	—	—	CZ.56106	5X/6831	2CZ.111676	5X/6831/B	2CZ.111455	5X/8553	508/1/03970	5X/9104
	3	2	—	—	—	—	—	—	—	—	—	—	—	—	—	—	—	—	—	—	—	—	—
	10	1	—	—	—	—	—	—	—	—	—	—	—	—	—	—	—	—	—	—	—	—	—
	7	2	—	—	—	CZ.1101A	—	CZ.1101A/2	—	CZ.1101A/3	5X/172	CZ.56076	5X/6364	—	—	CZ.71770	5X/6838	2CZ.111679	5X/6838/B	2CZ.111458	5X/7201	508/1/03973	5X/9107
—	2	—	—	—	—	—	—	—	—	—	—	—	—	—	—	—	—	—	—	—	—	—	
—	4	—	—	—	CZ.1120A	—	CZ.1120A/2	—	CZ.1120A/3	5X/173	CZ.50411	5X/6363	—	—	CZ.56110	5X/6825	2CZ.111677	5X/6825/B	2CZ.111456	5X/7326	508/1/03971	5X/9105	
—	5	—	—	—	—	—	—	—	—	—	CZ.50412	5X/6198	—	—	CZ.71769	5X/6830	2CZ.111678	5X/6830/B	2CZ.111457	5X/7550	508/1/03972	5X/9106	
1	—	3	—	—	CZ.1031A	—	CZ.1031A/2	—	CZ.1031A/3	5X/174	—	—	—	—	—	—	—	—	—	—	—	—	
—	—	3	—	—	CZ.1111A	—	CZ.1111A/2	—	CZ.1111A/3	5X/175	—	—	—	—	—	—	—	—	—	—	—	—	
1	—	3	—	—	CZ.2094	—	CZ.2094/2	—	CZ.2094/3	5X/176	CZ.27994	5X/6075	CZ.60523	—	—	CZ.71771	5X/6827	2CZ.111680	5X/6827/B	2CZ.111459	—	508/1/03974	5X/9108
3	—	3	—	—	CZ.2121A	—	CZ.2121A/2	—	CZ.2121A/3	5X/177	—	—	—	—	—	—	—	—	—	—	—	—	
5	3	—	—	—	CZ.1127A	—	CZ.1127A/2	—	CZ.1127A/3	5X/178	—	—	—	—	—	—	—	—	—	—	—	—	
6	4	—	—	—	—	—	—	—	—	—	—	—	—	—	—	—	—	—	—	—	—	—	
7	3	—	—	—	CZ.1089A	—	CZ.1089A/2	—	CZ.1089A/3	5X/179	—	—	—	—	—	—	—	—	—	—	—	—	
10	3	—	—	—	—	—	—	—	—	—	—	—	—	—	—	—	—	—	—	—	—	—	
12	—	—	—	—	CZ.2122A	—	CZ.2122A/2	—	CZ.2122A/3	5X/180	CZ.50413	5X/6199	—	—	CZ.56114	5X/6841	2CZ.111681	5X/6841/B	2CZ.111460	5X/7202	508/1/03975	5X/9109	
12	2	—	—	—	CZ.1102A	—	CZ.1102A/2	—	CZ.1102A/3	5X/181	CZ.27998	5X/6095	—	—	CZ.71772	5X/6844	2CZ.111682	5X/6844/B	2CZ.111461	5X/7203	508/1/03976	5X/9110	
16	—	—	—	—	CZ.1095A	—	CZ.1095A/2	—	CZ.1095A/3	5X/182	—	—	—	—	—	—	—	—	—	—	—	—	
—	6	—	—	—	—	—	—	—	—	—	CZ.27999	5X/6100	—	—	CZ.71773	5X/6833	2CZ.111683	5X/6833/B	2CZ.111462	5X/8568	508/1/03977	5X/9111	
—	—	4	—	—	CZ.10349A	—	CZ.10349A/2	—	CZ.10349A/3	5X/183	CZ.28000	5X/6105	CZ.60524	5X/6365	CZ.71774	5X/6828	2CZ.111684	5X/6828/B	2CZ.111463	5X/7204	508/1/03978	5X/9112	

STAGE 1 ← STAGE 2 → ← STAGE 3 → STAGE 4 STAGE 5 STAGE 6 STAGE 7

TABLE 4
Bulkhead Unit (Aluminium fig. 10)

Shell size	Contacts							Part No.	Ref. No.	Part No.	Ref. No.	Part No.	Ref. No.	Part No.	Ref. No.	Part No.	Ref. No.
	7	19	37	64	7sp	19sp	200										
A	2	—	—	—	—	—	—	CZ.2670	5X/66	CZ.2670/2	5X/4066	CZ.50363	5X/6262	2CZ.111413	5X/7161	508/1,06439	5X/9211
	3	—	—	—	—	—	—	CZ.2660	5X/67	CZ.2660/2	5X/4067	—	—	—	—	—	—
	3	—	—	—	1	—	—	CZ.2109	5X/68	CZ.2109/2	5X/4068	CZ.50364	5X/6263	2CZ.111414	5X/7162	508/1,06440	5X/9212
	—	1	—	—	—	—	—	—	—	—	—	CZ.28182	5X/6012	2CZ.111415	—	508/1,06441	5X/9213
Z	5	—	—	—	—	—	—	CZ.2688	5X/69	CZ.2688/2	5X/4069	CZ.50365	5X/6264	2CZ.111416	5X/7163	508/1,06442	5X/9214
	7	—	—	—	—	—	—	—	—	—	—	—	—	—	—	—	—
	—	2	—	—	—	—	—	CZ.2746	5X/70	CZ.2746/2	5X/4070	CZ.28185	5X/6027	2CZ.111417	5X/7164	508/1,06443	5X/9215
η	2	2	—	—	—	—	—	CZ.11408	5X/71	CZ.11408/2	5X/4071	CZ.50387	5X/6340	2CZ.111418	5X/7165	508/1,06444	5X/9216
	5	—	—	—	—	—	—	—	—	—	—	—	—	—	—	—	—
	7	—	—	—	—	—	—	CZ.2668	5X/72	CZ.2668/2	5X/4072	—	—	—	—	—	—
	9	—	—	—	—	—	—	—	—	—	—	CZ.50366	5X/6341	2CZ.111419	5X/7166	508/1,06445	5X/9217
	10	—	—	—	—	—	—	CZ.2105	5X/73	CZ.2105/2	5X/4073	—	—	—	—	—	—
	12	—	—	—	—	—	—	—	—	—	—	—	—	—	—	—	—
	1	3	—	—	—	—	—	—	—	—	—	—	—	—	—	—	—
	1	4	—	—	—	—	—	—	—	—	—	—	—	—	—	—	—
	2	2	—	—	—	—	—	CZ.2676	5X/74	CZ.2676/2	5X/4074	—	—	—	—	—	—
	2	4	—	—	—	—	—	—	—	—	—	CZ.50388	5X/6342	2CZ.111420	5X/8552	508/1,06446	5X/9218
	3	2	—	—	—	—	—	—	—	—	—	—	—	—	—	—	—
	10	1	—	—	—	—	—	—	—	—	—	—	—	—	—	—	—
	7	2	—	—	—	—	—	CZ.2653	5X/76	CZ.2653/2	5X/4076	CZ.56075	5X/6345	2CZ.111423	5X/7167	508/1,06449	5X/9221
	—	2	—	—	—	—	—	—	—	—	—	—	—	—	—	—	—
	—	4	—	—	—	—	—	CZ.2677	5X/77	CZ.2677/2	5X/4077	CZ.50367	5X/6343	2CZ.111421	5X/8342	508/1,06447	5X/9219
—	5	—	—	—	—	—	—	—	—	—	CZ.50368	5X/6344	2CZ.111422	5X/8559	508/1,06448	5X/9220	
1	—	3	—	—	—	—	CZ.2669	5X/78	CZ.2669/2	5X/4078	—	—	—	—	—	—	
—	—	3	—	—	—	—	CZ.12390	5X/79	CZ.12390/2	5X/4079	—	—	—	—	—	—	
C	1	—	3	—	—	—	—	CZ.1076	5X/80	CZ.1076/2	5X/4080	CZ.28194	5X/6072	2CZ.111424	—	508/1,06450	5X/9222
	3	—	3	—	—	—	—	CZ.2102	5X/81	CZ.2102/2	5X/4081	—	—	—	—	—	
	5	3	—	—	—	—	—	CZ.2681	5X/82	CZ.2681/2	5X/4082	—	—	—	—	—	
	6	4	—	—	—	—	—	—	—	—	—	—	—	—	—	—	
	7	3	—	—	—	—	—	CZ.2107	5X/83	CZ.2107/2	5X/4083	—	—	—	—	—	
	10	3	—	—	—	—	—	—	—	—	—	—	—	—	—	—	
	12	—	—	—	—	—	—	CZ.2104	5X/84	CZ.2104/2	5X/4084	CZ.50369	5X/6186	2CZ.111425	5X/7168	508/1,06451	5X/9223
	12	2	—	—	—	—	—	CZ.2100	5X/85	CZ.2100/2	5X/4085	CZ.28198	5X/6092	2CZ.111426	5X/7169	508/1,06452	5X/9224
	16	—	—	—	—	—	—	CZ.2673	5X/86	CZ.2673/2	5X/4086	—	—	—	—	—	
	—	6	—	—	—	—	—	—	—	—	—	CZ.28199	5X/6097	2CZ.111427	—	508/1,06453	5X/9225
—	—	4	—	—	—	—	CZ.10710	5X/87	CZ.10710/2	5X/4087	CZ.28200	5X/6102	2CZ.111428	5X/7170	508/1,06454	5X/9226	

STAGE 1

STAGE 2

STAGE 3

STAGE 4

STAGE 5

TABLE 4 *continued*

Shell size	Contacts						Part No.	Ref. No.	Part No.	Ref. No.	Part No.	Ref. No.	Part No.	Ref. No.	Part No.	Ref. No.
	7	19	37	64	7sp	19sp										
	2	2	4	—	—	—	—	—	—	CZ.28201	5X/6107	2CZ.111429	—	508/1/06455	5X/9227	
	4	—	—	2	—	—	CZ.2756	5X/88	CZ.2756/2	5X/4088	CZ.56069	5X/6346	2CZ.111434	5X/7377	508/1/06460	5X/9232
	4	6	—	—	—	—	—	—	—	—	—	—	—	—	—	
	4	7	2	—	—	—	—	—	—	CZ.28202	5X/6112	2CZ.111430	5X/8555	508/1/06456	5X/9228	
	6	2	2	—	—	—	—	—	—	CZ.28203	5X/6117	2CZ.111431	5X/7448	508/1/06457	5X/9229	
	7	7	2	—	—	—	CZ.12378	5X/89	CZ.12378/2	5X/4089	—	—	—	—	—	
	8	4	—	—	—	—	—	—	—	—	—	—	—	—	—	
	8	—	3	—	—	—	CZ.2106	5X/90	CZ.2106/2	5X/4090	—	—	—	—	—	
D	9	4	3	—	—	—	—	—	—	—	—	—	—	—	—	
	11	—	—	2	—	—	—	—	—	—	—	—	—	—	—	
	11	6	2	—	—	—	—	—	—	—	—	—	—	—	—	
	12	4	—	—	—	—	CZ.2675	5X/91	CZ.2675/2	5X/4091	CZ.28205	5X/6127	2CZ.111432	—	508/1/06458	5X/9230
	13	—	3	—	—	—	—	—	—	—	—	—	—	—	—	
	20	—	—	—	—	—	CZ.12367	5X/92	CZ.12367/2	5X/4092	—	—	—	—	—	
	24	2	—	—	—	—	CZ.22794	5X/2128	CZ.22982	5X/2181	CZ.50370	5X/6265	2CZ.111433	5X/7171	508/1/06459	5X/9231
	—	—	—	3	—	—	—	—	—	—	—	—	—	—	—	
	9	16	—	—	—	—	—	—	—	—	—	—	—	—	—	
	20	4	3	—	—	—	CZ.22796	5X/2129	CZ.22983	5X/2182	CZ.50371	5X/6347	2CZ.111435	5X/7633	508/1/06461	5X/9233
	—	—	—	—	—	1	—	—	—	—	—	—	—	—	—	
	—	—	—	—	—	1	—	—	—	—	—	—	—	—	—	
	—	—	—	—	—	1	—	—	—	—	—	—	—	—	—	
	—	—	—	—	—	1	CZ.1077	5X/93	—	—	—	—	—	—	—	
E	—	—	2	2	—	—	—	—	—	—	—	—	—	—	—	
	—	—	—	—	—	1	—	—	—	—	—	—	—	—	—	
	—	—	—	—	—	1	—	—	—	—	—	—	—	—	—	
	—	—	—	—	—	1	—	—	—	—	—	—	—	—	—	
	—	—	—	—	—	1	—	—	—	—	—	—	—	—	—	
	—	—	—	—	—	1	—	—	—	—	—	—	—	—	—	
	—	—	—	—	—	1	—	—	—	—	—	—	—	—	—	
	—	—	—	—	—	3	CZ.12379	5X/94	—	—	—	—	—	—	—	
	—	—	—	—	—	3	—	—	—	—	—	—	—	—	—	
	—	—	—	—	—	3	—	—	—	—	—	—	—	—	—	
	—	—	—	—	—	3	—	—	—	—	—	—	—	—	—	
F	—	—	—	—	—	3	—	—	—	—	—	—	—	—	—	
	—	—	—	—	—	3	—	—	—	—	—	—	—	—	—	
	—	—	—	—	—	3	—	—	—	—	—	—	—	—	—	
	—	—	—	—	—	3	—	—	—	—	—	—	—	—	—	
	—	—	—	—	—	3	—	—	—	—	—	—	—	—	—	
	—	—	—	—	—	3	—	—	—	—	—	—	—	—	—	

STAGE 1

STAGE 2

STAGE 3

STAGE 4

STAGE 5

TABLE 5
Pressurized Bulkhead Unit (Aluminium fig. 12)

Shell size	Contacts						Part No.	Ref. No.	Part No.	Ref. No.	Part No.	Ref. No.	Part No.	Ref. No.	
	7	19	37	64	7sp	19sp									200
A	2	—	—	—	—	—	CZ.28031	5X/6003	—	—	2CZ.138097	—	508/1/11431	5X/9506	
	3	—	—	—	—	—	—	—	—	—	—	—	—	—	
	3	—	—	—	1	—	CZ.28032	5X/6008	—	—	2CZ.138099	—	508/1/11432	5X/9508	
	—	1	—	—	—	—	CZ.28033	5X/6013	—	—	2CZ.138096	—	508/1/11433	5X/9505	
Z	5	—	—	—	—	—	CZ.28034	5X/6018	—	—	2CZ.138104	—	508/1/11434	5X/9513	
	7	—	—	—	—	—	—	—	—	—	—	—	—	—	
	—	2	—	—	—	—	CZ.28036	5X/6028	—	—	2CZ.138098	5X/8551	508/1/11435	5X/9507	
	2	2	—	—	—	—	CZ.28037	5X/6033	—	—	2CZ.138100	—	508/1/11436	5X/9509	
B	5	—	—	—	—	—	—	—	—	—	—	—	—	—	
	7	—	—	—	—	—	CZ.28044	5X/6068	—	—	—	—	—	—	
	9	—	—	—	—	—	CZ.28038	5X/6038	—	—	2CZ.138246	—	508/1/11437	5X/9519	
	10	—	—	—	—	—	CZ.28141	5X/6153	—	—	—	—	—	—	
	12	—	—	—	—	—	—	—	—	—	—	—	—	—	
	1	3	—	—	—	—	—	—	—	—	—	—	—	—	
	1	4	—	—	—	—	—	—	—	—	—	—	—	—	
	2	2	—	—	—	—	—	—	—	—	—	—	—	—	
	2	4	—	—	—	—	—	CZ.28039	5X/6043	—	—	2CZ.138106	—	508/1/11438	5X/9515
	3	2	—	—	—	—	—	—	—	—	—	—	—	—	
	10	1	—	—	—	—	—	—	—	—	—	—	—	—	
	7	2	—	—	—	—	—	CZ.57212	5X/6422	—	—	2CZ.138247	—	508/1/11453	5X/9520
C	—	2	—	—	—	—	—	—	—	—	—	—	—	—	
	—	4	—	—	—	—	CZ.28042	5X/6058	—	—	2CZ.138101	—	508/1/11439	5X/9510	
	—	5	—	—	—	—	CZ.28043	5X/6063	—	—	2CZ.138105	—	—	—	
	1	—	3	—	—	—	—	—	—	—	—	—	—	—	
	—	—	3	—	—	—	—	—	—	—	—	—	—	—	
	1	—	3	—	—	—	CZ.28046	5X/6078	—	—	2CZ.138102	—	508/1/11441	5X/9511	
	3	—	3	—	—	—	—	—	—	—	—	—	—	—	
	5	3	—	—	—	—	—	—	—	—	—	—	—	—	
	6	4	—	—	—	—	—	—	—	—	—	—	—	—	
	7	3	—	—	—	—	—	—	—	—	—	—	—	—	
10	3	—	—	—	—	—	—	—	—	—	—	—	—		
12	—	—	—	—	—	—	CZ.28048	5X/6088	—	—	2CZ.138111	5X/8557	508/1/11442	5X/9522	
12	2	—	—	—	—	—	CZ.28049	5X/6093	—	—	2CZ.138113	5X/8558	508/1/11443	5X/9524	
16	—	—	—	—	—	—	—	—	—	—	—	—	—		
—	6	—	—	—	—	—	CZ.28050	5X/6098	—	—	2CZ.138107	5X/8049	508/1/11444	5X/9516	
—	—	4	—	—	—	—	CZ.28051	5X/6103	—	—	2CZ.138103	—	508/1/11445	5X/9512	

← STAGE 1 →

STAGE 2

TABLE 5 continued

Shell size	Contacts							Part No.	Ref. No.	Part No.	Ref. No.	Part No.	Ref. No.	Part No.	Ref. No.	
	7	19	37	64	7sp	19sp	200									
D	2	2	4	—	—	—	—	CZ.28052	5X/6108	—	—	2CZ.138109	5X/7646	508/1/11446	5X/9518	
	4	—	—	2	—	—	—	CZ.57216	5X/6310	—	—	2CZ.138108	—	508/1/11451	5X/9517	
	4	6	—	—	—	—	—	—	—	—	—	—	—	—	—	
	4	7	2	—	—	—	—	CZ.28053	5X/6113	—	—	2CZ.138112	—	—	—	—
	6	2	2	—	—	—	—	CZ.28054	5X/6118	—	—	2CZ.138110	5X/8095	508/1/11448	5X/9521	
	7	7	2	—	—	—	—	—	—	—	—	—	—	508/1/11447	5X/9523	
	8	4	—	—	—	—	—	—	—	—	—	—	—	—	—	
	8	—	3	—	—	—	—	—	—	—	—	—	—	—	—	
	9	4	3	—	—	—	—	—	—	—	—	—	—	—	—	
	11	—	—	2	—	—	—	—	—	—	—	—	—	—	—	
	11	6	2	—	—	—	—	—	—	—	—	—	—	—	—	
	12	4	—	—	—	—	—	CZ.28056	5X/6128	CZ.71906	5X/6649	2CZ.138114	—	508/1/11449	5X/9525	
	13	—	3	—	—	—	—	—	—	—	—	—	—	—	—	
	20	—	—	—	—	—	—	—	—	—	—	—	—	—	—	
	24	2	—	—	—	—	—	CZ.28057	5X/6133	CZ.71733	5X/6634	2CZ.138115	5X/8556	508/1/11450	5X/9526	
	—	—	—	3	—	—	—	CZ.28058	5X/6138	—	—	—	—	—	—	
E	9	16	—	—	—	—	—	—	—	—	—	—	—	—	—	
	20	4	3	—	—	—	CZ.28059	5X/6143	—	—	2CZ.138116	—	508/1/11452	5X/9527		
	—	—	—	—	—	1	2	—	—	—	—	—	—	—		
	—	—	—	—	—	1	2	—	—	—	—	—	—	—		
	—	—	—	—	—	1	2	—	—	—	—	—	—	—		
	—	—	—	—	—	1	2	—	—	—	—	—	—	—		
	—	—	2	2	—	—	—	—	—	—	—	—	—	—		
	—	—	—	—	—	1	2	—	—	—	—	—	—	—		
	—	—	—	—	—	1	2	—	—	—	—	—	—	—		
	—	—	—	—	—	1	2	—	—	—	—	—	—	—		
F	—	—	—	—	—	—	3	—	—	—	—	—	—	—		
	—	—	—	—	—	—	3	—	—	—	—	—	—	—		
	—	—	—	—	—	—	3	—	—	—	—	—	—	—		
	—	—	—	—	—	—	3	—	—	—	—	—	—	—		
	—	—	—	—	—	—	3	—	—	—	—	—	—	—		
	—	—	—	—	—	—	3	—	—	—	—	—	—	—		
	—	—	—	—	—	—	3	—	—	—	—	—	—	—		
	—	—	—	—	—	—	3	—	—	—	—	—	—	—		

← STAGE 1 →

STAGE 2

TABLE 6
Fixed Unit (Brass and Steel fig. 5)

Shell size	Contacts							Part No.	BRASS				STEEL									
	7	19	37	64	7 sp	19sp	200		Ref. No.	Part No.	Ref. No.	Part No.	Ref. No.	Part No.	Ref. No.	Part No.	Ref. No.	Part No.	Ref. No.	Part No.		
A	2	—	—	—	—	—	—	CZ.27561	—	CZ.50310	—	—	—	—	CZ.28090	5X/6001	—	—	2CZ.108908	5X/7108	508/1/06416	5X/9188
	3	—	—	—	—	—	—	CZ.28343	—	—	—	—	—	—	—	—	—	—	—	—	—	
	3	—	—	—	1	—	—	CZ.27563	—	CZ.50311	—	—	—	—	CZ.28091	5X/6006	—	—	2CZ.84870	5X/7030	508/1/06417	5X/9189
	—	1	—	—	—	—	—	CZ.27564	—	CZ.50312	—	—	—	—	CZ.50372	5X/6302	—	—	2CZ.108907	5X/7050	508/1/06418	5X/9190
Z	5	—	—	—	—	—	—	CZ.27565	—	CZ.50313	—	—	—	—	CZ.28093	5X/6016	CZ.50622	—	2CZ.83945	5X/7032	508/1/06419	5X/9191
	7	—	—	—	—	—	—	—	—	—	—	—	—	—	—	—	—	—	—	—	—	
	—	2	—	—	—	—	—	CZ.27567	—	CZ.50314	—	—	—	—	CZ.50373	5X/6297	—	—	2CZ.108908	5X/7109	508/1/06420	5X/9192
	2	2	—	—	—	—	—	CZ.27568	—	CZ.50315	—	—	—	—	CZ.28096	5X/6031	—	—	2CZ.108909	5X/7110	508/1/06421	5X/9193
	5	—	—	—	—	—	—	CZ.26519	—	—	—	—	—	—	—	—	—	—	—	—	—	
	7	—	—	—	—	—	—	—	—	—	—	—	—	—	CZ.28103	5X/6066	—	—	—	—	—	
	9	—	—	—	—	—	—	CZ.27571	—	CZ.50316	—	—	—	—	CZ.28097	5X/6036	—	—	2CZ.84871	5X/7033	508/1/06422	5X/9194
	10	—	—	—	—	—	—	—	—	—	—	—	—	—	—	—	—	—	—	—	—	
	12	—	—	—	—	—	—	—	—	—	—	—	—	—	—	—	—	—	—	—	—	
	1	3	—	—	—	—	—	—	—	—	—	—	—	—	CZ.28099	5X/6046	—	—	—	—	—	
	1	4	—	—	—	—	—	—	—	—	—	—	—	—	—	—	—	—	—	—	—	
	2	2	—	—	—	—	—	—	—	—	—	—	—	—	—	—	—	—	—	—	—	
B	2	4	—	—	—	—	—	CZ.27577	—	CZ.50317	—	—	—	—	CZ.28098	5X/6041	—	—	2CZ.108910	5X/7111	508/1/06423	5X/9195
	3	2	—	—	—	—	—	—	—	—	—	—	—	—	—	—	—	—	—	—	—	
	10	1	—	—	—	—	—	—	—	—	—	—	—	—	—	—	—	—	—	—	—	
	7	2	—	—	—	—	—	CZ.57209	—	CZ.57210	—	—	—	—	CZ.56077	5X/6313	—	—	2CZ.108913	5X/7034	508/1/06426	5X/9198
	—	2	—	—	—	—	—	—	—	—	—	—	—	—	—	—	—	—	—	—	—	
	—	4	—	—	—	—	—	CZ.27582	—	CZ.50318	—	—	—	—	CZ.28101	5X/6056	—	—	2CZ.108911	5X/7112	508/1/06424	5X/9196
	—	5	—	—	—	—	—	CZ.27583	—	CZ.50319	—	—	—	—	CZ.28102	5X/6061	—	—	2CZ.108912	5X/7113	508/1/06425	5X/9197
	1	—	3	—	—	—	—	—	—	—	—	—	—	—	—	—	—	—	—	—	—	
	—	—	3	—	—	—	—	—	—	—	—	—	—	—	—	—	—	—	—	—	—	
	1	—	3	—	—	—	—	CZ.27585	—	CZ.50320	—	CZ.60489	—	—	CZ.28105	5X/6076	CZ.60478	5X/6337	2CZ.108914	5X/7031	508/1/06427	5X/9199
	3	—	3	—	—	—	—	—	—	—	—	—	—	—	—	—	—	—	—	—	—	
	5	3	—	—	—	—	—	—	—	—	—	—	—	—	—	—	—	—	—	—	—	
	6	4	—	—	—	—	—	CZ.27588	—	—	—	—	—	—	—	—	—	—	—	—	—	
	7	3	—	—	—	—	—	—	—	—	—	—	—	—	—	—	—	—	—	—	—	
C	10	3	—	—	—	—	—	—	—	—	—	—	—	—	—	—	—	—	—	—	—	
	12	—	—	—	—	—	—	CZ.27591	—	CZ.50321	—	—	—	—	CZ.28107	5X/6086	—	—	2CZ.108915	5X/7035	508/1/06428	5X/9200
	12	2	—	—	—	—	—	CZ.27592	—	CZ.50322	—	—	—	—	CZ.50377	5X/6207	—	—	2CZ.108916	5X/7036	508/1/06429	5X/9201
	16	—	—	—	—	—	—	CZ.27593	—	CZ.28353	—	—	—	—	CZ.64214	—	—	—	—	—	—	
	—	6	—	—	—	—	—	CZ.27594	—	CZ.50323	—	—	—	—	CZ.50378	5X/6761	—	—	2CZ.108917	5X/7114	508/1/06430	5X/9202
	—	—	4	—	—	—	—	CZ.50675	—	CZ.50324	—	CZ.60490	—	—	CZ.50379	—	CZ.60477	5X/6717	2CZ.108918	5X/7115	508/1/06431	5X/9203

STAGE 2 ← STAGE 3 → STAGE 4 STAGE 5

TABLE 7
Normal Free Unit (Brass and Steel fig. 8)

Shell size	← BRASS →					← STEEL →																	
	7	19	37	64	7sp 15sp 200	Part No.	Ref. No.	Part No.	Ref. No.	Part No.	Ref. No.	Part No.	Ref. No.	Part No.	Ref. No.	Part No.	Ref. No.	Part No.	Ref. No.	Part No.	Ref. No.		
A	2	—	—	—	—	CZ.27501	—	CZ.30442	—			CZ.27900	5X/6004	—	—	CZ.56085	5X/6374	2CZ.111692	5X/6374/B	2CZ.84872	5X/7038	508/1/03986	5X/9120
	3	—	—	—	—	CZ.27502	—	CZ.54982	—														
	3	—	—	1	—	—	—	CZ.50443	—			CZ.27901	5X/6009	CZ.62422	—	CZ.56089	5X/6375	2CZ.111693	5X/6375/B	2CZ.84873	5X/7039	508/1/03987	5X/9121
	—	1	—	—	—	—	—	CZ.50444	—			CZ.50416	5X/6421	—	—	CZ.71758	5X/6929	2CZ.111694	5X/6929/B	2CZ.108943	5X/7127	508/1/03988	5X/9122
Z	5	—	—	—	—	—	—	CZ.50445	—			CZ.27903	5X/6019	—	—	CZ.56093	5X/6376	2CZ.111695	5X/6376/B	2CZ.84874	5X/7128	508/1/03989	5X/9123
	7	—	—	—	—	—	—	—	—														
	—	2	—	—	—	—	—	CZ.50446	—			CZ.50417	5X/6298	—	—	CZ.64772	5X/6378	2CZ.111696	5X/6378/B	2CZ.108944	5X/7044	508/1/03990	5X/9124
	2	2	—	—	—	—	—	CZ.50447	—			CZ.27906	5X/6034	—	—	CZ.56097	5X/6377	2CZ.111697	5X/6377/B	2CZ.108945	5X/7042	508/1/03991	5X/9125
	5	—	—	—	—	—	—	—	—														
	7	—	—	—	—	—	—	—	—			CZ.27913	5X/6069	—	—								
	9	—	—	—	—	CZ.27511	—	CZ.50448	—			CZ.27907	5X/6039	—	—	CZ.56101	5X/6379	2CZ.111698	5X/6379/B	2CZ.84875	5X/7045	508/1/03992	5X/9126
	10	—	—	—	—	—	—	—	—			CZ.28137	5X/6154	—	—								
	12	—	—	—	—	—	—	—	—														
	1	3	—	—	—	—	—	—	—			CZ.27989	5X/6050	—	—								
	1	4	—	—	—	—	—	—	—														
	2	2	—	—	—	—	—	—	—														
B	2	4	—	—	—	—	—	CZ.50449	—			CZ.27908	5X/6044	—	—	CZ.56105	5X/6380	2CZ.111699	5X/6380/B	2CZ.108946	5X/7129	508/1/03993	5X/9127
	3	2	—	—	—	—	—	2CZ.83489	—														
	10	1	—	—	—	—	—	—	—														
	7	2	—	—	—	CZ.27922	—	CZ.57205	—			CZ.56078	5X/6321	—	—	CZ.64771	5X/6383	2CZ.111702	5X/6383/B	2CZ.108949	5X/7046	508/1/03996	5X/9130
	—	2	—	—	—	—	—	2CZ.83490	—														
	—	4	—	—	—	—	—	CZ.50450	—			CZ.27911	5X/6059	—	—	CZ.56109	5X/6381	2CZ.111700	5X/6381/B	2CZ.108947	5X/7040	508/1/03994	5X/9128
	—	5	—	—	—	—	—	CZ.50451	—			CZ.27912	5X/6064	—	—	CZ.64770	5X/6382	2CZ.111701	5X/6382/B	2CZ.108948	5X/7043	508/1/03995	5X/9129
	1	3	—	—	—	—	—	—	—			CZ.27909	5X/6049	—	—								
	—	3	—	—	—	—	—	—	—														
	1	3	—	—	—	CZ.50452	—	CZ.60521	—			CZ.27915	5X/6079	CZ.60498	5X/6359	CZ.73359	5X/6608	2CZ.111703	5X/6608/B	2CZ.108950	5X/7041	508/1/03997	5X/9131
	3	3	—	—	—	—	—	—	—														
	5	3	—	—	—	—	—	—	—														
	6	4	—	—	—	CZ.27531	—	—	—														
	7	3	—	—	—	—	—	—	—														
	10	3	—	—	—	—	—	—	—														
	12	—	—	—	—	—	—	CZ.50453	—			CZ.27917	5X/6089	—	—	CZ.56113	5X/6384	2CZ.111704	5X/6384/B	2CZ.84876	5X/7047	508/1/03998	5X/9132
	12	2	—	—	—	—	—	CZ.50454	—			CZ.50421	5X/6201	—	—	CZ.64517	5X/6385	2CZ.111705	5X/6385/B	2CZ.84877	5X/7048	508/1/03999	5X/9133
	16	—	—	—	—	CZ.27536	—	—	—														
	—	6	—	—	—	—	—	CZ.50455	—			CZ.50422	—	—	—	CZ.66956	5X/6962	2CZ.111706	5X/6962/B	2CZ.108951	5X/7130	508/1/04000	5X/9134
	—	4	—	—	—	—	—	CZ.60518	—			CZ.50423	—	CZ.73360	5X/6695	CZ.60501	5X/6873	2CZ.111707	5X/6873/B	2CZ.108952	5X/7131	508/1/04001	5X/9135

STAGE 2

STAGE 3

← STAGE 3 →

STAGE 4

STAGE 5

STAGE 6

STAGE 7

TABLE 7 continued

Shell size	CONTACTS						PARTS																		
	7	19	37	64	7sp	19sp	200	Part No.	Ref. No.	Part No.	Ref. No.	Part No.	Ref. No.	Part No.	Ref. No.	Part No.	Ref. No.	Part No.	Ref. No.	Part No.	Ref. No.				
	2	2	4	—	—	—	—	CZ.50457	—	CZ.60516	—			CZ.50424	—	CZ.73361	—	CZ.60503	5X/7384	2CZ.111708	—	2CZ.108953	5X/8506	508/1/04002	5X/9136
	4	—	—	2	—	—	—	—	—	CZ.57207	—			CZ.56067	5X/6299	—	—	CZ.71764	5X/6611	2CZ.111713	5X/6611/B	2CZ.108957	5X/7335	508/1/04007	5X/9141
	4	6	—	—	—	—	—	—	—	—	—			—	—	—	—	—	—	—	—	—	—	—	—
	4	7	2	—	—	—	—	CZ.50458	—	CZ.60514	—			CZ.50425	—	CZ.73362	—	CZ.60505	5X/6963	2CZ.111709	5X/6963/B	2CZ.108954	5X/7132	508/1/04003	5X/9137
	6	2	2	—	—	—	—	CZ.50459	—	CZ.60517	—			CZ.50426	5X/6306	CZ.73363	—	CZ.60502	—	2CZ.111710	—	2CZ.108955	5X/7904	508/1/04004	5X/9138
	7	7	2	—	—	—	—	—	—	—	—			—	—	—	—	—	—	—	—	—	—	—	—
	8	4	—	—	—	—	—	—	—	—	—			—	—	—	—	—	—	—	—	—	—	—	—
D	8	—	3	—	—	—	—	—	—	—	—			—	—	—	—	—	—	—	—	—	—	—	—
	9	4	3	—	—	—	—	—	—	—	—			—	—	—	—	—	—	—	—	—	—	—	—
	11	—	—	2	—	—	—	—	—	—	—			—	—	—	—	—	—	—	—	—	—	—	—
	11	6	2	—	—	—	—	—	—	—	—			—	—	—	—	—	—	—	—	—	—	—	—
	12	4	—	—	—	—	—	—	—	CZ.50460	—			CZ.50427	5X/6307	—	—	CZ.64773	5X/6386	2CZ.111711	5X/6386/B	2CZ.108956	5X/7446	508/1/04005	5X/9139
	13	—	3	—	—	—	—	—	—	—	—			—	—	—	—	—	—	—	—	—	—	—	—
	20	—	—	—	—	—	—	—	—	—	—			—	—	—	—	—	—	—	—	—	—	—	—
	24	2	—	—	—	—	—	—	—	CZ.50461	—			CZ.27926	5X/6134	—	—	CZ.71763	5X/6615	2CZ.111712	5X/6615/B	2CZ.84878	5X/7049	508/1/04006	5X/9140
	—	—	—	3	—	—	—	—	—	—	—			CZ.27927	5X/6139	—	—	—	—	—	—	—	—	—	—
	9	16	—	—	—	—	—	—	—	—	—			—	—	—	—	—	—	—	—	—	—	—	—
	20	4	3	—	—	—	—	CZ.50463	—	CZ.60511	—			CZ.27928	5X/6144	CZ.60508	5X/6360	CZ.71756	5X/6617	2CZ.111714	5X/6617/B	2CZ.108942	5X/7589	508/1/04008	5X/9142
	—	—	—	—	—	—	—	—	—	—	—			—	—	—	—	—	—	—	—	—	—	—	—
	—	—	—	—	—	—	—	—	—	—	—			—	—	—	—	—	—	—	—	—	—	—	—
	—	—	—	—	—	—	—	—	—	—	—			—	—	—	—	—	—	—	—	—	—	—	—
	—	—	—	—	—	—	—	—	—	—	—			—	—	—	—	—	—	—	—	—	—	—	—
E	—	—	2	2	—	—	—	—	—	—	—			—	—	—	—	—	—	—	—	—	—	—	—
	—	—	—	—	—	—	—	—	—	—	—			—	—	—	—	—	—	—	—	—	—	—	—
	—	—	—	—	—	—	—	—	—	—	—			—	—	—	—	—	—	—	—	—	—	—	—
	—	—	—	—	—	—	—	—	—	—	—			—	—	—	—	—	—	—	—	—	—	—	—
	—	—	—	—	—	—	—	—	—	—	—			—	—	—	—	—	—	—	—	—	—	—	—
	—	—	—	—	—	—	—	—	—	—	—			—	—	—	—	—	—	—	—	—	—	—	—
	—	—	—	—	—	—	—	—	—	—	—			—	—	—	—	—	—	—	—	—	—	—	—
	—	—	—	—	—	—	—	—	—	—	—			—	—	—	—	—	—	—	—	—	—	—	—
	—	—	—	—	—	—	—	—	—	—	—			—	—	—	—	—	—	—	—	—	—	—	—
F	—	—	—	—	—	—	—	—	—	—	—			—	—	—	—	—	—	—	—	—	—	—	—
	—	—	—	—	—	—	—	—	—	—	—			—	—	—	—	—	—	—	—	—	—	—	—
	—	—	—	—	—	—	—	—	—	—	—			—	—	—	—	—	—	—	—	—	—	—	—
	—	—	—	—	—	—	—	—	—	—	—			—	—	—	—	—	—	—	—	—	—	—	—
	—	—	—	—	—	—	—	—	—	—	—			—	—	—	—	—	—	—	—	—	—	—	—
	—	—	—	—	—	—	—	—	—	—	—			—	—	—	—	—	—	—	—	—	—	—	—
	—	—	—	—	—	—	—	—	—	—	—			—	—	—	—	—	—	—	—	—	—	—	—
	—	—	—	—	—	—	—	—	—	—	—			—	—	—	—	—	—	—	—	—	—	—	—
	—	—	—	—	—	—	—	—	—	—	—			—	—	—	—	—	—	—	—	—	—	—	—
	—	—	—	—	—	—	—	—	—	—	—			—	—	—	—	—	—	—	—	—	—	—	—
	—	—	—	—	—	—	—	—	—	—	—			—	—	—	—	—	—	—	—	—	—	—	—

STAGE 2 STAGE 3 ← STAGE 3 → STAGE 4 STAGE 5 STAGE 6 STAGE

TABLE 8 continued

Shell size	CONTACTS					BRASS				STEEL														
	7	19	37	64	7sp 19sp 200	Part No.	Ref. No.	Part No.	Ref. No.	Part No.	Ref. No.	Part No.	Ref. No.	Part No.	Ref. No.	Part No.	Ref. No.	Part No.	Ref. No.	Part No.	Ref. No.			
	2	2	4			CZ-50478		CZ-60515					CZ-50437		CZ-60504		CZ-71789		2CZ-111731		2CZ-108969		508/1,04024	5X/9158
	4		2			CZ-57208							CZ-56072	5X/6372			CZ-71794	5X/6612	2CZ-111736	5X/6612/B	2CZ-108973	5X/8734	508/1,04029	5X/9163
	4	6																						
	4	7	2			CZ-50479		CZ-60513					CZ-50438		CZ-60506		CZ-71790		2CZ-111732		2CZ-108970		508/1,04025	5X/9159
	6	2	2			CZ-50480		CZ-60512					CZ-50439		CZ-60507		CZ-71791		2CZ-111733		2CZ-108971		508/1,04026	5X/9160
	7	7	2																					
	8	4																						
	8		3																					
D	9	4	3																					
	11		2																					
	11	6	2																					
	12	4				CZ-50481							CZ-50440	5X/6625			CZ-71792	5X/6930	2CZ-111734	5X/6930/B	2CZ-108972		508/1,04027	5X/9161
	13		3																					
	20																							
	24	2				CZ-50482							CZ-28006	5X/6135			CZ-71793	5X/6616	2CZ-111735	5X/6616/B	2CZ-108974	5X/7039	508/1,04028	5X/9162
			3										CZ-28007	5X/6140										
	9	16																						
	20	4	3			CZ-50484		CZ-60510					CZ-28008	5X/6145	CZ-60509	5X/6373	CZ-71795	5X/6618	2CZ-111737	5X/6618/B	2CZ-108974	5X/7449	508/1,04030	5X/9164

TABLE 9

Bulkhead Unit (Brass and Steel fig. 10)

Shell size	BRASS							STEEL									
	7	19	37	64	7sp	19sp	200	Part No.	Ref. No.	Part No.	Ref. No.	Part No.	Ref. No.	Part No.	Ref. No.		
A	2	—	—	—	—	—	—	CZ.50332	—	—	—	CZ.28180	5X/6002	2CZ.84864	5X/7021	508/1/06462	5X/9234
	3	—	—	—	—	—	—	—	—	—	—	—	—	—	—	—	—
	3	—	—	—	1	—	—	CZ.50333	—	—	—	CZ.28181	5X/6007	2CZ.84865	5X/7022	508/1/06463	5X/9235
Z	—	1	—	—	—	—	—	CZ.50334	—	—	—	CZ.50385	5X/6968	2CZ.108925	5X/7119	508/1/06464	5X/9236
	5	—	—	—	—	—	—	CZ.50335	—	—	—	CZ.28183	5X/6017	2CZ.108926	5X/7120	508/1/06465	5X/9237
	7	—	—	—	—	—	—	—	—	—	—	—	—	—	—	—	—
	—	2	—	—	—	—	—	CZ.50336	—	—	—	CZ.50386	5X/6925	2CZ.108927	5X/7121	508/1/06466	5X/9238
	2	2	—	—	—	—	—	CZ.50337	—	—	—	CZ.28186	5X/6032	2CZ.108928	5X/7122	508/1/06467	5X/9239
	5	—	—	—	—	—	—	—	—	—	—	—	—	—	—	—	—
B	7	—	—	—	—	—	—	—	—	—	—	CZ.28193	5X/6067	—	—	—	—
	9	—	—	—	—	—	—	CZ.50338	—	—	—	CZ.28187	5X/6037	2CZ.84866	5X/7025	508/1/06468	5X/9240
	10	—	—	—	—	—	—	—	—	—	—	CZ.28140	5X/6152	—	—	—	—
	12	—	—	—	—	—	—	—	—	—	—	—	—	—	—	—	—
	1	3	—	—	—	—	—	—	—	—	—	—	—	—	—	—	—
	1	4	—	—	—	—	—	—	—	—	—	—	—	—	—	—	—
	2	2	—	—	—	—	—	—	—	—	—	—	—	—	—	—	—
	2	4	—	—	—	—	—	CZ.50339	—	—	—	CZ.28188	5X/6042	2CZ.108929	5X/7123	508/1/06469	5X/9241
	3	2	—	—	—	—	—	—	—	—	—	—	—	—	—	—	—
	10	1	—	—	—	—	—	—	—	—	—	—	—	—	—	—	—
	7	2	—	—	—	—	—	CZ.57211	—	—	—	CZ.56079	5X/6348	2CZ.108932	5X/7026	508/1/06472	5X/9244
	—	2	—	—	—	—	—	—	—	—	—	—	—	—	—	—	—
C	—	4	—	—	—	—	—	CZ.50340	—	—	—	CZ.28191	5X/6057	2CZ.108930	5X/7023	508/1/06470	5X/9242
	—	5	—	—	—	—	—	CZ.50341	—	—	—	CZ.28192	5X/6062	2CZ.108931	5X/7124	508/1/06471	5X/9243
	1	—	3	—	—	—	—	—	—	—	—	—	—	—	—	—	—
	—	—	3	—	—	—	—	—	—	—	—	—	—	—	—	—	—
	1	—	3	—	—	—	—	CZ.50342	—	—	—	CZ.28195	5X/6077	2CZ.108933	5X/7024	508/1/06473	5X/9245
	3	—	3	—	—	—	—	—	—	—	—	—	—	—	—	—	—
	5	3	—	—	—	—	—	—	—	—	—	—	—	—	—	—	—
	6	4	—	—	—	—	—	—	—	—	—	—	—	—	—	—	—
	7	3	—	—	—	—	—	—	—	—	—	—	—	—	—	—	—
	10	3	—	—	—	—	—	—	—	—	—	—	—	—	—	—	—
	12	—	—	—	—	—	—	CZ.50343	—	—	—	CZ.28197	5X/6087	2CZ.84867	5X/7027	508/1/06474	5X/9246
	12	2	—	—	—	—	—	CZ.50344	—	—	—	CZ.50390	5X/6291	2CZ.84868	5X/7028	508/1/06475	5X/9247
16	—	—	—	—	—	—	—	—	—	—	—	—	—	—	—	—	
—	6	—	—	—	—	—	CZ.50345	—	—	—	CZ.50391	5X/6420	2CZ.108934	—	508/1/06476	5X/9248	
—	—	4	—	—	—	—	CZ.50346	—	—	—	CZ.50392	5X/6871	2CZ.108935	5X/7125	508/1/06477	5X/9249	

STAGE 3

STAGE 3

STAGE 4

STAGE 5

TABLE 10
Fixed Unit (Detachable Leads fig. 13)

	"A" SIZE	ALUMINIUM		STEEL	
		Plessey Part No.	Ref. No.	Plessey Part No.	Ref. No.
STAGE 1	A 2/0/0	CZ.22238	5X/2183		
STAGE 2	A 2/0/0	CZ.76498	5X/6720	2CZ.111486	
STAGE 3	A 2/0/0	2CZ.140052		2CZ.140053	

TABLE 11
Free Unit (Short Reach fig. 14)

	"A" SIZE	ALUMINIUM		STEEL	
		Part No.	Ref. No.	Part No.	Ref. No.
STAGE 1	A 2/0/0	CZ.27004	5X/2928		
	A 4/0/0	CZ.50951	5X/6156		
STAGE 2	A 2/0/0	CZ.140462			
	A 4/0/0	CZ 140461			
STAGE 3	A 2/0/0	508/1/11507	5X/8747	508/1/11509	5X/7573
	A 4/0/0	508/1/11508	5X/7642	508/1/11510	

TABLE 12
Heavy-Duty Pressurized Bulkhead Connector Block (fig. 15)

Connections	Part. No.	Ref. No.	Dimensions (in.)			Weight (oz.)	Cover	
			A	B Dia.	C		Part No.	Ref. No.
Three 200A	CZ.51091	5H/112	3-62	3-62	1-937	19-6	Z 51094	5H/111
Two 200A	CZ.51097	5H/110	3-62	3-62	1-937	18-2	Z 51094	5H/111
One 19A								

Add .125 in to each end of dimension "A" if covers are used.

TABLE 13
Quick-Release Fixed and Free Units (fig. 16)

"B" SIZE	ALUMINIUM		STEEL	
	Plessey Part No.	Ref. No.	Plessey Part No.	Ref. No.
FIXED UNIT				
B 0/5/0	CZ.12353	5X/95		
B 0/4/0	CZ.19147	5X/3157		
B 1/3/0	CZ.19145	5X/3158		
B 7/2/0	CZ.51390	5X/6158		
B 7/2/0 Bulkhead	CZ.53206	5X/6651		
STAGE 1				
FREE UNIT				
B 0/5/0	CZ.10348			
B 0/4/0	CZ.19148	5X/3159		
B 1/3/0	CZ.19146	5X/3160		
B 7/2/0	CZ.51395	5X/6159		
FIXED UNIT				
B 7/2/0			CZ.70185	5X/6470
STAGE 2				
FREE UNIT				
B 7/2/0			CZ.70186	5X/6471
STAGE 3				
FREE UNIT				
B 7/2/0			CZ.83851	5X/6847

TABLE 14
Thermocouple unit

Shell size and Contact Arrangement	Code	Thermo-couple Contacts						Shell	Climatic Proof Fixed Unit	Bulkhead Unit	Pressurized Bulkhead Unit	Normal Free Unit	Reverse Free Unit
		Contact Designation see fig. 20	Current Rating (Amps.)	Material	Contact Designation see fig. 20	Current Rating (Amps.)	Material						
A 2/0/0	1	A	7	Constantan	B	7	Brass	Alum.	2CZ.139864	—	2CZ.139865	2CZ.139866	2CZ.139867
A 2/0/0	1	A	7	Constantan	B	7	Brass	Steel	2CZ.139868	2CZ.139869	—	2CZ.139870	2CZ.139871
A 2/0/0	1	A	7	Chromel	B	7	Alumel	Steel	—	2CZ.139872	—	2CZ.139873	2CZ.139874
Z 0/2/0	5	1	19	Constantan	2	19	Brass	Steel	2CZ.139875	—	—	2CZ.139876	—
Z 0/2/0	5	1	19	Chromel	2	19	Alumel	Alum.	2CZ.139877	—	2CZ.139878	2CZ.139879	2CZ.139880
Z 0/2/0	5	1	19	Chromel	2	19	Alumel	Steel	2CZ.139881	2CZ.139882	—	2CZ.139883	2CZ.139913
Z 5/0/0	4	A, C, E	7	Chromel	B, D	7	Alumel	Steel	2CZ.139884	2CZ.139885	—	2CZ.139886	2CZ.139887
B 7/2/0	11	1	19	Chromel	2	19	Alumel	Steel	2CZ.139888	—	—	2CZ.139889	—
		A, B, C, D, E, F, G	7	Brass									
B 0/4/0	9	1, 3	19	Constantan	2, 4	19	Brass	Steel	2CZ.139890	2CZ.139891	—	2CZ.139892	2CZ.139893
B 0/4/0	9	1, 3	19	Chromel	2, 4	19	Alumel	Steel	2CZ.139894	2CZ.139895	—	2CZ.139896	2CZ.139897
B 0/4/0	9	1, 3	19	Constantan	2, 4	19	Brass	Alum.	—	2CZ.139898	2CZ.139899	2CZ.139900	2CZ.139901
C 0/0/4	16	1, 3	37	Chromel	2, 4	37	Alumel	Steel	2CZ.139902	2CZ.139903	—	2CZ.139904	2CZ.139905
C 12/0/0	13	A, C, E, G, J, L	7	Constantan	B, D, F, H, K, M	7	Brass	Alum.	2CZ.139906	2CZ.139907	2CZ.139908	2CZ.139909	2CZ.139910
E 20/4/3	23	M, O, Q, S, U, D	7	Constantan	A, B, C, E, F, G, H, J, K, L, N, P, R, T	7	Brass	Steel	2CZ.139911	—	—	2CZ.139912	—
		1, 2, 3, 4	19		5, 6, 7	37	Brass Brass Brass						

* These codes represent the various contact arrangements that are illustrated on fig. 20.

TABLE 15
Contacts (fig. 21)
Socket contacts

Type A (used in stages 1, 2 and 3 of the free unit)

Contacts	Part No.	Ref. No.
7A	Z.27330	5X/3237
7A (special)	Z.28143	5X/3239
19A	Z.28144	5X/3241

Type B (used in stages 1, 2, 3, 4 and 5 of the free unit; is obsolete and must not now be used)

Contact	Part No.	Ref. No.
37A	Z.60366	5X/6951
64A	CZ.56408	5X/6400

Type C (used in stages 4 and 5 of the free unit; is obsolete and must not now be used)

Contact	Part No.	Ref. No.
7A	Z.56404	5X/6924
7A (special)	Z.56480	5X/6949
19A	Z.56405	5X/6950

Type D (used in stages 6, 7 of the free unit and in stages 1, 2, 3, if the front and rear insulators are the same as in stage 6 or 7)

Contact	Part No.	Ref. No.
7A	508/1/11188	5X/7516
7A (special)	508/1/11189	5X/7517

Type D (used in stages 6, 7 of the free unit and in stages 1, 2, 3, 4, 5, if the front and rear insulators are the same as in stage 6 or 7)

Contact	Part No.	Ref. No.
19A	508/1/11190	5X/7331

Type D (used in stages 4, 5, 6 and 7 of the free unit)

Contact	Part No.	Ref. No.
37A	508/1/11191	5X/7514
64A	508/1/11192	5X/7520

TABLE 15 *continued*

Type E (used in stages 4, 5, 6 and 7 of the free unit)

Contact	Part No.	Ref. No.
19A	508/1/11190	5X/7331
37A	508/1/11191	5X/7514
64A	508/1/11192	5X/7520

Pin contacts

Contact	Part No.	
	Fixed unit	Bulkhead unit
7A	508/2/11245	508/2/11250
7A (special)	508/2/11246	508/2/11251
19A	508/2/11247	508/2/11252
37A	508/2/11248	508/2/11253
64A	508/2/11249	508/2/11254

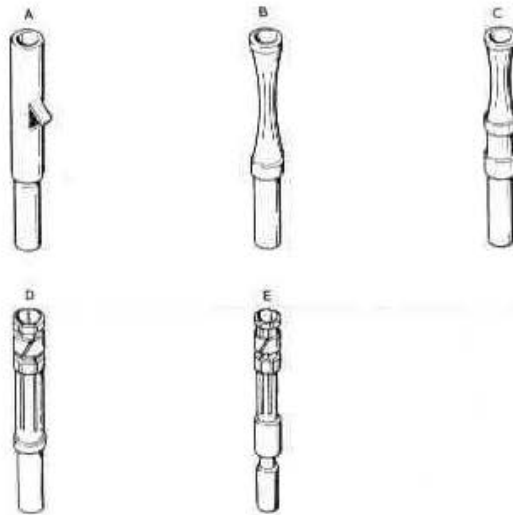

Fig. 21. Contacts

TABLE 16
Dimensions and Panel Piercing Details—(Fixed Unit) (fig. 22)

Shell size	Dimensions (in.)						Fixing holes
	A	B	C	D	E	F	
A	0.941	1.384	0.497	0.781	0.937	0.720	6 B.A.
Z	0.941	1.509	0.679	0.934	1.125	0.875	6 B.A.
B	0.941	1.509	0.897	1.153	1.250	1.000	6 B.A.
C	0.941	1.509	1.047	1.341	1.437	1.187	6 B.A.
D	0.941	1.509	1.416	1.715	1.750	1.469	6 B.A.
E	0.941	1.509	1.672	1.965	2.000	1.687	4 B.A.

Shell size	Dimensions (in.)					recommended minimum distance between centres of similar size units (in.)
	G	H	J	K	L	
A	0.797	0.720	0.120	0.957	0.625	1.125
Z	0.953	0.875	0.120	1.125	0.687	1.250
B	1.171	1.000	0.120	1.250	0.812	1.500
C	1.359	1.187	0.120	1.437	0.875	1.625
D	1.734	1.469	0.120	1.750	1.062	2.000
E	1.984	1.687	0.152	2.000	1.187	2.250

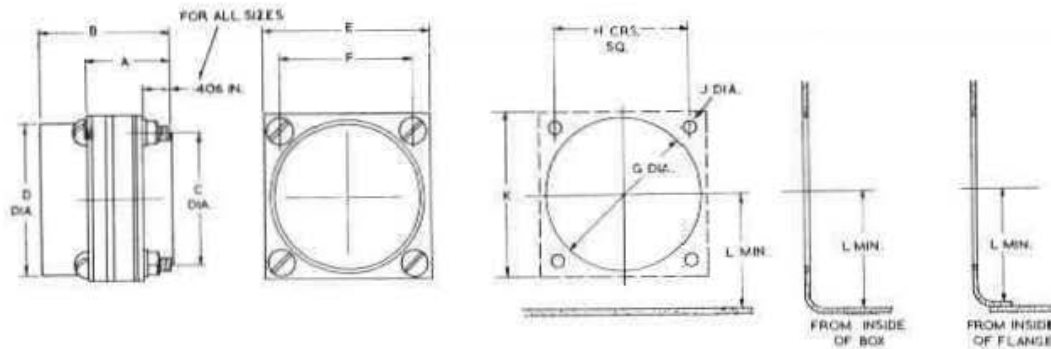

Fig. 22. Panel piercing details, fixed unit

TABLE 17
Dimensions and Panel Piercing Details—(Bulkhead Unit) (fig. 23)

Shell size	Dimensions (in.)					Fixing holes
	A	B	C	D	E	
A	1.182	1.625	0.937	0.781	0.720	6 B.A.
Z	1.307	1.875	1.125	0.934	0.875	6 B.A.
B	1.307	1.875	1.250	1.153	1.000	6 B.A.
C	1.307	1.875	1.437	1.341	1.187	6 B.A.
D	1.307	1.875	1.750	1.715	1.469	6 B.A.
E	1.307	1.875	2.000	1.965	1.687	4 B.A.

Shell size	Dimensions (in.)					recommended minimum distance between centres of similar size units (in.)
	G	H	J	K	L	
A	0.797	0.720	0.120	0.957	0.625	1.125
Z	0.953	0.875	0.120	1.125	0.687	1.250
B	1.171	1.000	0.120	1.250	0.812	1.500
C	1.359	1.187	0.120	1.437	0.875	1.625
D	1.734	1.469	0.120	1.750	1.062	2.000
E	1.984	1.687	0.152	2.000	1.187	2.250

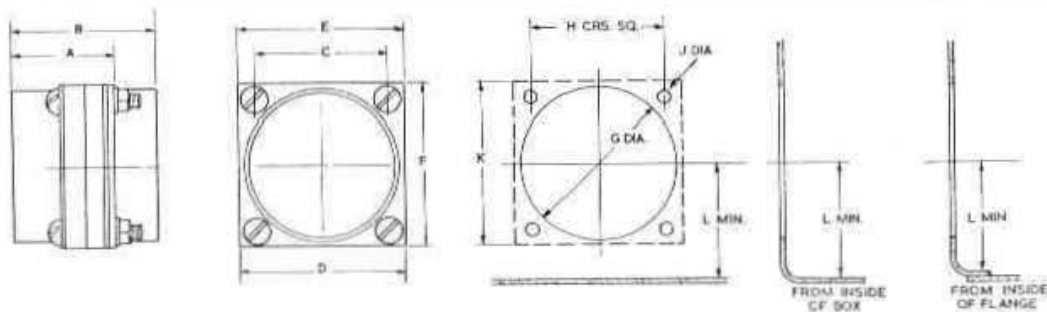

Fig. 23. Panel piercing details, bulkhead unit

TABLE 18

Dimensions and panel piercing details—(pressurized bulkhead unit) (fig. 24)

Shell size	Dimensions (in.)						Fixing holes	Holes No. off
	A	B	C	D	E	F		
A	1.201	1.763	1.572	0.781	90°	1.018	6 B.A.	4
Z	1.327	2.036	1.812	0.934	90°	1.237	6 B.A.	4
B	1.327	2.036	2.000	1.153	45°	1.414	6 B.A.	8
C	1.327	2.036	2.312	1.341	45°	1.678	6 B.A.	8
D	1.327	2.036	2.687	1.715	45°	2.076	6 B.A.	8
E	1.327	2.036	3.062	1.965	45°	2.386	4 B.A.	8

Shell size	Dimensions (in.)			recommended minimum distance between centres of similar size units (in.)
	G	H	J	
A	0.797	1.018	0.120	1.625
Z	0.953	1.237	0.120	1.875
B	1.171	1.414	0.120	2.062
C	1.359	1.678	0.120	2.375
D	1.734	2.076	0.120	2.750
E	1.984	2.386	0.152	3.125

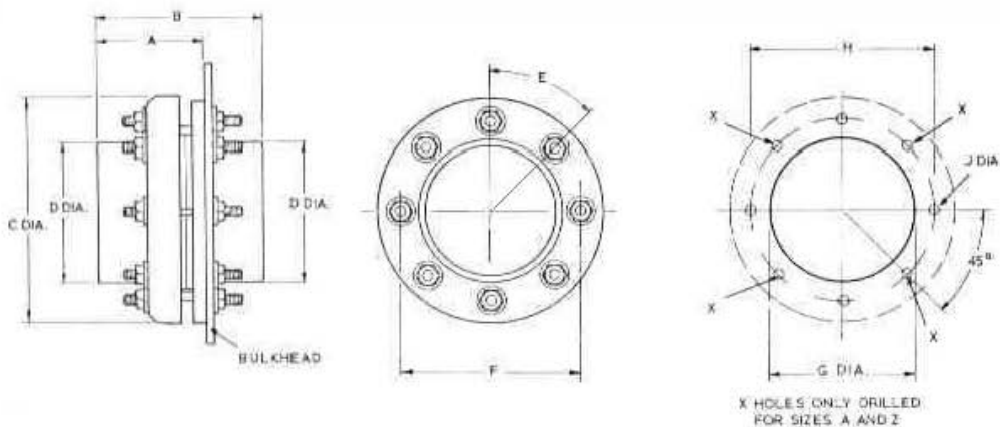

Fig. 24. Panel piercing details, pressurized unit

TABLE 19
Dimensions and Panel Piercing Details—Heavy-duty Bulkhead Unit (fig. 25)

Connections	Dimensions (in.)			
	A	B	C	D
3 × 200A	3.62	3.62	0.937	2.25
2 × 200A	3.62	3.62	0.937	2.25
1 × 19A				

Dimensions (in.)			Recommended minimum distance between centres of similar size units (in.)
G	H	J	
2.38	3.062	0.152	3.687

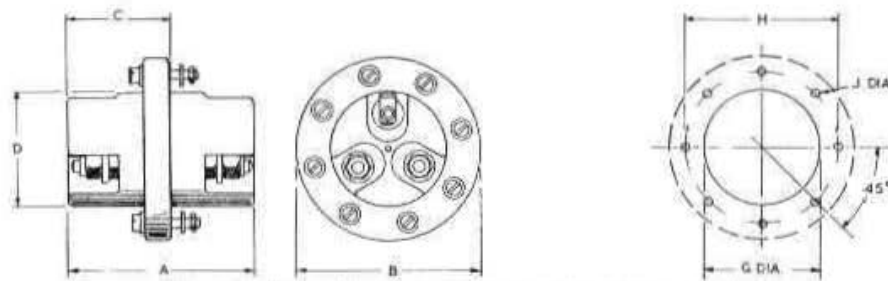

Fig. 25. Panel piercing details, heavy duty bulkhead unit

TABLE 20
Dimensions and Panel Piercing Details—Quick-Release Unit (fig. 26)

Shell size	Mated Pair Dimensions (in.)						
	A	B	C	D	E	F	G
B	4.75	1.59	1.180	4.30	2.20	1.70	2.23

Shell size	Free Unit Dimensions (in.)	
	H	J
B	1.766	1.187

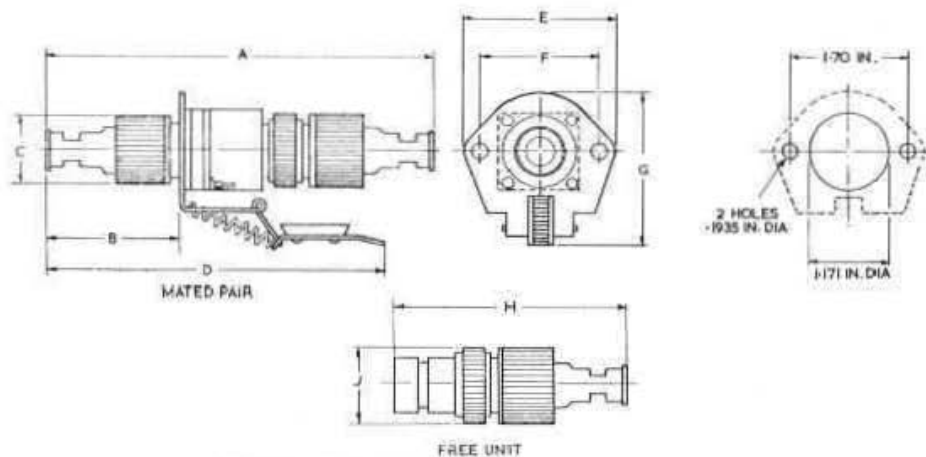

Fig. 26. Panel piercing details, quick release unit

TABLE 21
Dimensions—Fixed Unit (Detachable Leads fig. 27)

Shell size	Dimensions (in.)		
	A	B	C
A	1.019	0.784	0.937

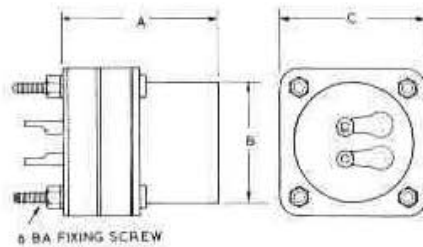

Fig. 27. Dimensions fixed unit detachable leads

TABLE 22
Dimensions—Free Unit (fig. 28)

Shell size	Dimensions (in.)			
	A	B	C	D
A	0.610	1.750	0.885	0.692 24 T.P.I.
Z	0.735	1.750	1.050	0.875 20 T.P.I.
B	0.735	1.812	1.250	1.062 20 T.P.I.
C	0.735	1.812	1.435	1.250 20 T.P.I.
D	0.735	2.375	1.810	1.625 20 T.P.I.
E	0.735	2.394	1.995	1.875 20 T.P.I.

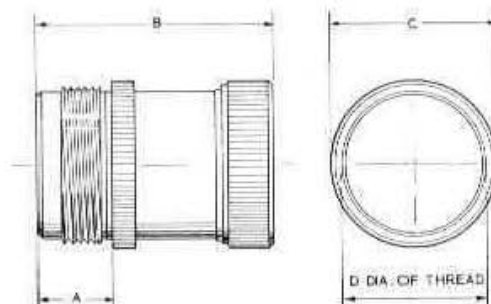

Fig. 28. Dimensions free unit

TABLE 23
Dimensions—Short-reach Free Unit (fig. 29)

Shell size	Dimensions (in.)					
	A	B	C	D	E	F
A	1.715	0.609	0.692	1.120	1.332	0.692

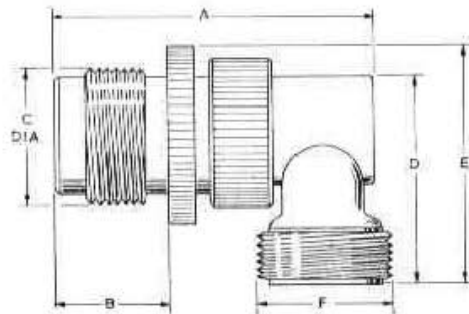

Fig. 29. Dimensions short reach free unit

TABLE 24
Spares and Replacements (Up-rated Versions)

Description	Material	Part Numbers					
		A	Z	B	C	D	E
Fixed or Bulkhead Unit Shell	Aluminium	508/2/11330	/11355	/11334	/11936	/11337	/11338
	Steel	508/2/11339	/11331* /11341 /11340*	/11333* /11343 /11342*	/11335* /11345 /11344*	/11346	/11347
Fixed or Bulkhead Unit Shell Gasket	Asbestos Fibre	508/4/06069/001	/002	/003	/004	/005	/006
Fixed or Bulkhead Unit Insulator Gasket	Asbestos Fibre	508/4/11290/001	/002	/003	/004	/005	/006
Fixed or Bulkhead Unit Seating Gasket	Silicone Rubber	508/4/11288/001	/002	/003	/004	/005	/006
Bulkhead Unit Reverse Seating Gasket	Silicone Rubber	508/4/11289/001	/002	/003	/004	/005	/006
Free Unit Shell	Aluminium	508/2/11354	/11331	/11356	/11357	/11358	/11359
	Steel	508/2/11360	/11361	/11362	/11363	/11364	/11365
Circlip	Steel	2Z.110344	2Z.110343	2Z.110345	2Z.110346	2Z.110347	2Z.111197
Insulating Ring	Glass Fibre (P.T.F.E. Coated)	508/4/11293	/11294	/11295	/11296	/11297	/11298
Insulating Sleeve	Glass Fibre (P.T.F.E. Coated)	508/4/11300	/11301	/11302	/11303	/11304	/11305
Free Unit Ferrule Gasket	Asbestos Fibre	508/4/11291/001	/002	/003	/004	/005	/006
Free Unit Sealing Gasket†	Synthetic Rubber	508/4/11292/001	/002	/003	/004	/005	/006
Thrust Washer	Steel	508/2/11299/001	/002	/003	/004	/005	/006
Packing Cap Fixed or Bulkhead Unit	Polythene	099/4/00032/018	/021	/023	/025	/029	/032
Packing Cap Free Unit	Polythene	999/4/00032/015	/019	/022	/024	/028	/031

* Required on fixed units containing all 7 amp. pins (codes 4, 7 and 13).

† A Free Unit Sealing Gasket is supplied with each free unit to enable it to mate with an early version of fixed or bulkhead unit. When mating units are both of the up-rated version, the gasket should be discarded.

TABLE 25
Fixed Unit Sealing Cap (fig. 30)

Size	Part No.	Ref. No.	A (in.)	Weight (oz.)
A	508/4/11180	5X/1963	0.250	0.11
Z	508/4/11181	5X/1964	0.250	0.16
B	508/4/11182	5X/1965	0.250	0.22
C	508/4/11183	5X/1966	0.250	0.25
D	508/4/11184	5X/1967	0.250	0.39
E	508/4/11185	5X/2185	0.250	0.48

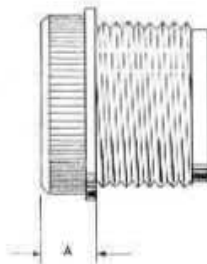

Fig. 30. Fixed unit sealing cap

TABLE 26
Fixed Unit Screening Cap (fig. 31)

Size	Part No.	Ref. No.	A (in.)	Weight (oz.)
A	Z.13031	5X/1097	0.250	0.20
Z	Z.13106	5X/1088	0.250	0.29
B	Z.13032	5X/1089	0.250	0.37
C	Z.13033	5X/1575	0.250	0.46

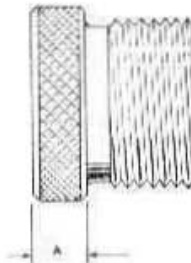

Fig. 31. Fixed unit screening cap

TABLE 27
Coupling Unit (fig. 32)

Size	ALUMINIUM			STEEL (Nickel Plated)			Dimensions	
	Part No.	Ref. No.	Weight (oz.)	Part No.	Ref. No.	Weight (oz.)	A (in.)	B (in.)
A	508/2/11410	5X/6312	0.11	508/2/11416	5X/6301	0.34	0.692 × 24 T.P.I.	0.585
Z	508/2/11411	5X/6500	0.18	508/2/11417	5X/6293	0.53	0.875 × 20 T.P.I.	0.723
B	508/2/11412	5X/6405	0.21	508/2/11418	5X/6294	0.65	1.062 × 20 T.P.I.	0.877
C	508/2/11413	5X/6424	0.26	508/2/11419	5X/6295	0.78	1.250 × 20 T.P.I.	1.022
D	508/2/11414	5X/6425	0.33	508/2/11420	5X/6296	0.99	1.625 × 20 T.P.I.	1.440
E	508/2/11415	5X/6820	0.42	508/2/11421	5X/6325	1.27	1.875 × 20 T.P.I.	1.567

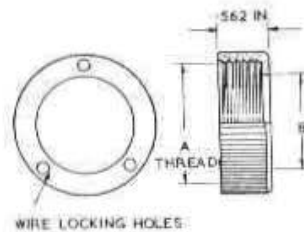

Fig. 32. Coupling unit

TABLE 28
Fixed Unit Shroud (fig. 33)

Size	ALUMINIUM			STEEL (Nickel plated)			A (in.)
	Part No.	Ref. No.	Wt. (oz.)	Part No.	Ref. No.	Wt. (oz.)	
A	508/2/11203	5X/282	0.2	508/2/11209/006	5X/	0.3	0.750
Z	508/2/11204	5X/283	0.3	508/2/11210/006	—	0.8	0.750
B	508/2/11205	5X/284	0.3	508/3/11226/006	—	0.9	0.750
C	508/2/11206	5X/285	0.4	508/2/11227/006	—	1.3	0.750
D	508/2/11207	5X/286	0.6	508/2/11228/006	—	1.7	0.750
E	508/2/11208	5X/287	0.8	508/2/11229/006	—	2.3	1.375

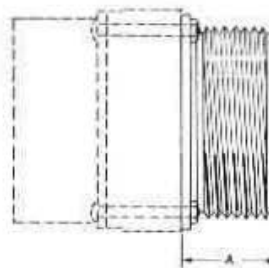

Fig. 33. Fixed unit shroud

TABLE 29
 Ferrule Plate Assembly (fig. 34)

Size	Part No.	Ref. No.	Ferrule size	Tubing size	A	B	Wt. (oz.)	Clamp ring Part No.	Ref. No.
A	CZ.24626	5X/6850	A	$\frac{3}{8}$	0.722	1.000	0.27	508/2/11407/100	5X/1529
	CZ.24628	5X/6631	Z	$\frac{1}{4}$	0.909	1.000	0.45	508/2/11407/002	5X/6440
Z	CZ.24632	5X/6603	Z	$\frac{1}{4}$	0.722	1.187	0.35	508/2/11407/002	5X/6440
	CZ.24634	5X/6797	B	$\frac{3}{8}$	0.909	1.187	0.54	508/2/11407/003	5X/6488
B	CZ.24636	—	Z	$\frac{1}{4}$	0.909	1.312	0.39	508/2/11407/002	5X/6440
	CZ.24638	5X/6604	B	$\frac{3}{8}$	0.722	1.312	0.42	508/2/11407/003	5X/6488
	CZ.24640	5X/6605	C	$\frac{1}{2}$	0.909	1.312	0.73	508/2/11407/004	5X/6489
C	CZ.24642	—	B	$\frac{3}{8}$	0.909	1.500	0.46	508/2/11407/003	5X/6488
	CZ.24644	5X/6177	C	$\frac{1}{2}$	0.722	1.500	0.83	508/2/11407/004	5X/6489
	CZ.24646	5X/6178	D	1	1.026	1.500	1.00	508/2/11407/005	5X/3143
D	CZ.24648	5X/6628	C	$\frac{1}{2}$	0.909	1.812	0.60	508/2/11407/004	5X/6489
	CZ.24650	5X/6180	D	1	0.839	1.812	1.35	508/2/11407/005	5X/3143
	CZ.24652	—	E	$1\frac{1}{4}$	1.026	1.812	1.12	508/2/11407/006	5X/6490
E	CZ.24654	—	D	1	1.026	2.06	2.0	508/2/11407/005	5X/3143
	CZ.24656	5X/6606	E	$1\frac{1}{4}$	0.839	2.06	1.6	508/2/11407/006	5X/6490
	CZ.24658	—	dia. 1.525	$1\frac{1}{2}$	1.151	2.06	1.75	508/2/11407/007	—

Panel piercing details are shown on Table 16. Dimension "A" Tolerance ± 0.064 in. All these assemblies are electro-tin finish except CZ.24634 and CZ.24640 which are dull nickel plate.

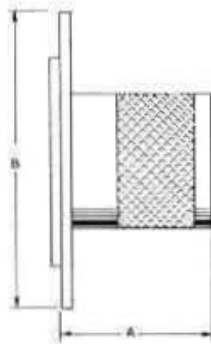

Fig. 34. Ferrule plate assembly

TABLE 30
Clamp Rings (fig. 35)

Size	PLAIN TYPE /BRASS) (Cadmium Plated)			SCREW TYPE (STEEL) (Cadmium Plated)		
	Part No.	Ref. No.	Wt. (oz.)	Part No.	Ref. No.	Wt. (oz.)
A	508/2/11407/100	5X/1529	0.04	—	—	—
Z	508/2/11407/200	5X/1530	0.07	CZ.23144/Z	5X/6440	0.24
B	508/2/11407/300	5X/1531	0.07	CZ.23144/B	5X/6488	0.25
C	508/2/11407/400	5X/1532	0.09	CZ.23144/C	5X/6489	0.26
D	508/2/11407/500	5X/1533	0.14	CZ.23144/D	5X/3143	0.30
E	508/2/11407/600	5X/1534	0.18	CZ.23144/E	5X/6490	0.35
Dia. 1.525 (in.)	508/2/11407/700	5X/1535	0.23	CZ.23144/F	—	0.38

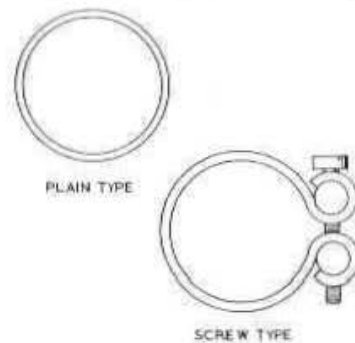

Fig. 35. Clamp rings

TABLE 31
Inner and Outer Ferrules (fig. 36)

Size	INNER					OUTER				
	Part No.	Ref. No.	A (in.)	B (in.)	Wt. (oz.)	Part No.	Ref. No.	A (in.)	B (in.)	Wt. (oz.)
A	508/2/11422/100	5X/-	0.250	0.628	0.04	508/2/11423/106	5X/-	0.256	0.628	0.04
Z	508/2/11422/200	—	0.325	0.800	0.07	508/2/11423/206	—	0.325	0.800	0.07
B	508/2/11422/300	—	0.360	0.990	0.10	508/2/11423/306	—	0.360	0.990	0.11
C	508/2/11422/400	—	0.395	1.175	0.14	508/2/11423/406	—	0.395	1.175	0.15
D	508/2/11422/500	—	0.450	1.547	0.23	508/2/11423/506	—	0.450	1.547	0.25
E	508/2/11422/600	—	0.562	1.795	0.37	508/2/11423/606	—	0.562	1.795	0.39

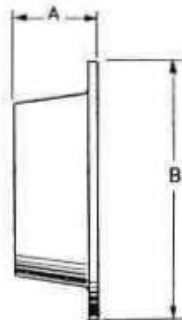

Fig. 36. Inner and outer ferrules

TABLE 32
Ferrules for Plastic Tubing (fig. 37)

Size	Part No.	STANDARD Tubing					Part No.	OVERSIZE Tubing				
		Ref. No.	Size I/D (in.)	A (in.)	B (in.)	Wt. (oz.)		Ref. No.	Size I/D (in.)	A (in.)	B (in.)	Wt. (oz.)
A	508/2/11405/100	5X/1522	0-375	0-750	0-628	0-14	508/2/11406/100	5X/1546	0-500	0-937	0-628	0-20
Z	508/2/11405/200	5X/1523	0-500	0-750	0-800	0-19	508/2/11406/200	5X/1547	0-625	0-937	0-800	0-21
B	508/2/11405/300	5X/1524	0-625	0-750	0-990	0-22	508/2/11406/300	5X/1548	0-750	0-937	0-990	0-34
C	508/2/11405/400	5X/1525	0-750	0-750	1-175	0-30	508/2/11406/400	5X/1549	1-000	1-062	1-175	0-53
D	508/2/11405/500	5X/1526	1-000	0-875	1-547	0-58	508/2/11406/500	5X/1550	1-250	1-062	1-547	0-77
E	508/2/11405/600	5X/1527	1-250	0-875	1-795	0-81	508/2/11406/600	5X/2187	1-500	1-062	1-795	0-96

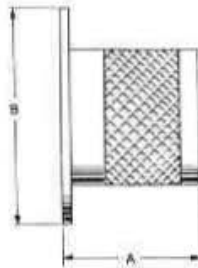

Fig. 37. Ferrules for plastic tubing

TABLE 33
Conduit Ferrule Type "H" (fig. 38)

Size	Conduit Size (in.)	ALUMINIUM			BRASS (Nickel Plated)			DIMENSIONS			
		Part No.	Ref. No.	Wt. (oz.)	Part No.	Ref. No.	Wt. (oz.)	A (in.)	B (in.)	C (in.)	D (in.)
A	1/2	508/2/11366/001	5X/1570	0-04	508/2/11782/016	5X/-	0-09	0-250	0-447	0-437	0-628
		508/2/11366/019	5X/1344	0-04	508/2/11424/006	—	0-11	0-375	0-572	0-437	0-628
Z	3/8	508/2/11366/018	5X/1571	0-05	508/2/11782/126	—	0-13	0-375	0-572	0-437	0-800
		508/2/11366/017	5X/1343	0-05	508/2/11782/116	—	0-14	0-500	0-697	0-437	0-800
B	1/2	508/2/11366/016	5X/1074	0-06	508/2/11782/026	—	0-21	0-375	0-572	0-437	0-990
		508/2/11366/009	5X/1327	0-07	508/2/11782/046	—	0-21	0-625	0-828	0-500	0-990
C	3/4	508/2/11366/011	5X/1328	0-07	508/2/11782/096	—	0-19	0-500	0-697	0-437	0-990
		508/2/11366/004	5X/1325	0-09	508/2/11782/106	5X/-	0-26	0-625	0-828	0-500	1-175
D	1	508/2/11366/003	5X/909	0-08	508/2/11782/056	—	0-24	0-750	0-982	0-500	1-175
		508/2/11366/012	5X/1329	0-13	508/2/11782/146	—	0-30	0-750	0-982	0-500	1-574
E	1 1/2	508/2/21366/013	5X/912	0-15	508/2/11782/166	—	0-45	1-000	1-267	0-562	1-574
		508/2/11366/015	5X/1330	0-19	508/2/11782/066	—	0-50	1-000	1-267	0-625	1-800

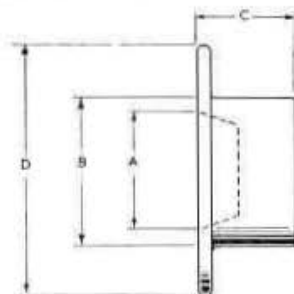

Fig. 38. Conduit ferrule Type H

TABLE 34
Conduit Ferrule Type G (fig. 39)

Conduit Size (in.)	ALUMINIUM			BRASS (Nickel Plated)			Dimensions		
	Part No.	Ref. No.	Wt. (oz.)	Part No.	Ref. No.	Wt. (oz.)	A (in.)	B (in.)	C (in.)
3/8	Z.1431	5X/2073	0.03	2Z.139938	5X/-	—	0.375	0.572	0.437
	Z.1432	5X/2074	0.04	2Z.139939	—	0.12	0.500	0.697	0.437
	Z.1433	5X/1342	0.05	2Z.139940	—	0.14	0.625	0.828	0.437
	Z.1434	5X/2075	0.07	2Z.139941	—	—	0.750	0.982	0.500
1	Z.1435	5X/2076	0.11	2Z.139942	—	0.30	1.000	1.267	0.625
1 1/4	Z.1450	5X/2077	0.11	—	—	—	1.250	1.522	0.625

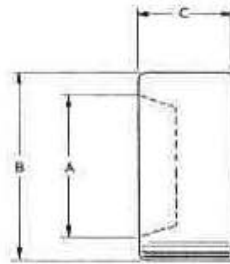

Fig. 39. Conduit ferrule Type G

TABLE 35
Elbow Assembly (fig. 40)

Size	Part No.	Ref. No.	A (in.)	B (in.)	Wt. (oz.)
A	508/1/11456	5X/-	0.70	0.81	1.20
Z	508/1/11457	—	0.72	0.93	1.42
B	508/1/11458	—	0.84	1.02	1.80
C	508/1/11459	—	0.94	1.02	2.56
D	508/1/11460	—	1.12	1.31	4.18
E	508/1/11461	—	1.18	1.50	5.24

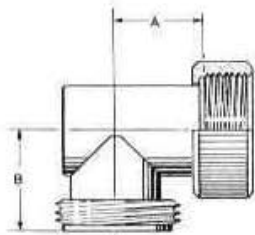

Fig. 40. Elbow assembly

TABLE 36
Tee Connector

Size	Part No.	A (in.)	B (in.)	Wt. (oz.)
A	2CZ.139950	2.02	0.81	1.09
Z	2CZ.139951	2.24	0.93	2.12
B	2CZ.139952	2.50	1.02	3.34
C	2CZ.139953	2.74	1.02	3.55
D	2CZ.139954	3.00	1.31	6.86
E	2CZ.139955	3.25	1.50	6.96

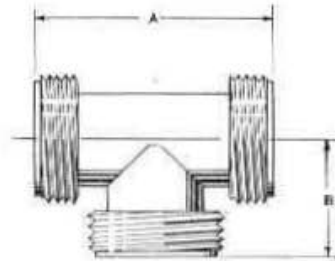

Fig. 41. Tee connector

TABLE 37
Cut Ferrule (Round Base) (fig. 42)

Size	Part No.	Ref. No.	Wt. (oz.)	A (in.)	B (in.)	C (in.)	D (in.)	E (in.)
A	508/2/...../006	5X/						
	07871	8668	0.22	0.275	0.375	0.625	0.036	0.625
	07872	8724	0.21	0.355	0.500	0.687	0.036	0.625
	07873	8718	0.23	0.405	0.468	0.625	0.036	0.625
	07874	8959	0.23	0.442	0.500	0.687	0.020	0.625
Z	508/2/...../006	5X/						
	15485	8708	0.33	0.355	0.437	0.750	0.036	0.800
	15486	8961	0.33	0.505	0.625	0.687	0.020	0.800
B	508/2/...../006	5X/						
	07878	8962	0.42	0.355	0.500	1.000	0.048	0.990
	07879	8963	0.35	0.405	0.593	1.187	0.036	0.990
	07880	8964	0.40	0.505	0.650	1.187	0.036	0.990
	07881	8965	0.40	0.605	0.725	0.687	0.020	0.990
	07882	8966	0.43	0.723	0.812	0.687	0.020	0.990
	07883	8967	0.43	0.755	0.812	0.687	0.020	0.990
C	508/2/...../006	5X/						
	15487	8968	0.54	0.405	0.593	1.187	0.048	1.175
	15488	8489	0.50	0.605	0.781	1.187	0.036	1.175
	15489	8665	0.56	0.705	0.906	1.187	0.036	1.175
	15490	8974	0.46	0.905	1.000	0.875	0.036	1.175
D	508/2/...../006	5X/						
	15491	8669	0.68	0.805	1.000	1.125	0.036	1.550
	15492	8709	0.78	1.005	1.281	1.125	0.036	1.550
E	508/2/...../006	5X/						
	15493	8974	0.95	1.205	1.500	1.125	0.036	1.800
	15494	8490	0.94	1.255	1.537	0.875	0.036	1.800

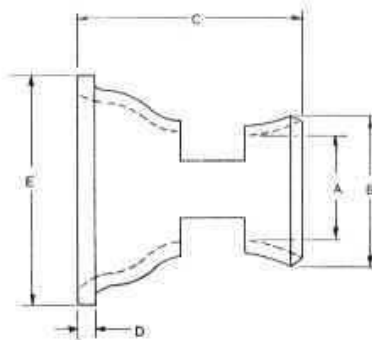

Fig. 42. Cut ferrule round base

TABLE 38
Cut Ferrule (Square Base) (fig. 43)

Size	Part No.	Ref. No.	Wt. (oz.)	A (in.)	B (in.)	C (in.)	D (in.)	E (in.)
A	508/2/.....	5X/						
	15495	10163	0.47	0.320	0.406	0.875	0.036	0.937
	15496	10164	0.48	0.405	0.468	0.875	0.036	0.937
	15497	10165	0.56	0.405	0.500	0.750	0.036	0.937
Z	508/2/15498	5X/ 10166	0.56	0.500	0.562	1.187	0.036	1.125
B	508/2/.....	5X1						
	15499	10167	0.56	0.500	0.593	1.187	0.036	1.250
	15500	10168	0.56	0.505	0.625	1.187	0.036	1.250
	15501	10169	0.56	0.600	0.687	1.187	0.036	1.250
	15502	10170	0.58	0.687	0.750	1.187	0.036	1.250
	15503	10171	0.64	0.705	0.906	1.187	0.036	1.250
15504	10172	0.68	0.905	1.000	0.875	0.036	1.250	
C	508/2/15505	5X/ 10173	0.75	0.750	0.812	1.187	0.036	1.437
D	508/2/15506	5X/ 10174	0.82	0.805	0.875	1.375	0.036	1.750
	508/2/15507	10175	0.84	1.000	1.062	1.500	0.036	1.750

Note: Panel piercing details are shown on Table 16.

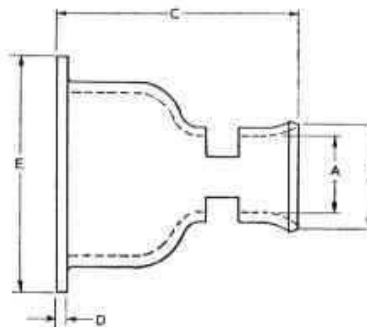

Fig. 43. Cut ferrule square base

TABLE 39
Ejector Tool (fig. 19)

Tool to fit contact size	Part No.	Ref. No.
7A (special)	CZ.23294	5X/2236
7A	CZ.23306	5X/2237
19A	CZ.23300	5X/2238
37A	CZ.23295	5X/2239
64A	CZ.23291	5X/2240