

EN - For pricing and availability in your local country please visit one of the below links:

DE - Informationen zu Preisen und Verfügbarkeit in Ihrem Land erhalten Sie über die unten aufgeführten Links:

FR - Pour connaître les tarifs et la disponibilité dans votre pays, cliquez sur l'un des liens suivants:

[00-8016-038-000-001](#)

[00-8016-056-000-001](#)

[00-8016-038-000-007](#)

[60-8017-0513-00-339](#)

[00-8016-020-000-001](#)

EN

This Datasheet is presented by the manufacturer

DE

Dieses Datenblatt wird vom Hersteller bereitgestellt

FR

Cette fiche technique est présentée par le fabricant

AVXX
A KYOCERA GROUP COMPANY



ELCO
Varicon™ Input/Output
Rack and Panel Connectors

Contents

- The Varicon Range 2
- Introduction to Varicon 3
- Input/Output Rack and Panel Connectors**
 - Series 8014 6
 - Series 8016 12
 - Varilok® Loose Contacts – Connector Polarization 22
 - Series 8026 24
 - Series 8223 28
- In-line Two Piece Plug and Receptacles**
 - Series 8020 30
 - Series 8022 31
- Two Piece Printed Circuit Board Plug and Receptacles**
 - Series 8218 32
 - Series 8219 34
 - Series 7008 36
 - Series 7022 38
 - Series 7023 39
 - Series 7024 40
 - Series 7038 42
- Contact Strips**
 - Series 7000 44
 - Series 5101 45
 - Series 5203 46
 - Series 5204 47
 - Series 5208 48
 - Series 5301 49
 - Series 5304 50
- Installation Equipment 51

The Varicon Range



Pitch	Number of Contacts	Body Style	Termination Types	Current Rating (Amps)	Series Number
0.050"	2 to 152	Plugs and Receptacles	Staggered, Fixed: Solder, Eyelet	5	8218
0.050"	18, 30, 36, 42, 54, 72	Plugs and Receptacles	Staggered, Fixed: Straight & Right Angle Solder, Eyelet	5	8219
0.075" x 0.130" & 0.075" x 0.150"	20, 38, 56, 90, 120	Plugs and Receptacles	Staggered, Removable: Taper Tab, Eyelet, Wire Wrap, Crimp	8	8016
0.100"	17, 23, 29, 35, 41	Receptacles	As Series 7024	8	7008
0.100"	17, 23, 29, 35, 41, 47	Plugs	Staggered, Fixed: Solder	6	7022
0.100"	17, 23, 29, 35, 41, 47	Receptacles	Staggered, Fixed: Solder	6	7023
0.100"	17, 23, 29, 35, 41	Receptacles	Staggered, Fixed: Solder, Taper Tab, Eyelet, Wire Wrap, Bus Line	8	7024
0.100"	17, 23, 29, 35, 41, 47	Receptacles	Staggered, Removable: Taper Tab, Eyelet, Wire Wrap, Crimp	8	7038
0.100"	33, 75, 117, 165	Plugs and Receptacles	Wire Wrap, Crimp	5	8026
0.100"	24, 48, 72, 96	Plugs and Receptacles	Square Grid Dual Row, Fixed: Straight and Right Angle Solder, Eyelet, Wire Wrap, Crimp Wrappable Removable	5	8223
4mm	50, 64	Plug and Receptacle	Crimp	2	8014
0.200"	2, 3	Plugs and Receptacles	In-line Fixed: Solder Crimp	8.5	8020
0.200"	3	Plug and Receptacle	In-line Fixed: Solder Crimp	8.5	8022

Introduction

Elco's Varicon product range is available as two-piece input / output and board level connectors (intermateable plugs and receptacles). Varicon contacts are also available in strips, on disposable carriers, ready for staking to p.c. cards. They all use the famous, fork-like Varicon® (fixed) or Varilok® (insertable / removable) hermaphroditic contact design.

Elco's range conforms to MIL-E-5400, MIL-E-8189 and MIL-T-21200. Varicon® (fixed contact) conforms to MIL-C-21097, Varilok® (insertable / removable) under MIL-C-28731, and Mini-Varilok® under MIL-C-55302.

VARICON DESIGN ADVANTAGES

Elco's hermaphroditic Varicon contact utilizes a fork-like design incorporating four large mating surfaces that are coined to achieve exceptional hardness and smoothness. The mating surfaces are wedged together by the spring-like design of the contact and by the innate properties of the contact material. The Varicon contact has proven its reliability in innumerable applications and with over one-million contacts being produced daily, billions of successful, trouble-free operating hours have been logged.

FEATURES

- Four intimate contact areas, electrically parallel
- High current carrying capability, excellent heat dissipation
- Self-cleaning, wiping action burnishes contacting surfaces reducing constrictive resistance
- Low contact resistance 3 to 4 milliohms
- Stable in vibration and adverse environments
- High contact normal pressure achieved at low stress levels

HIGH RELIABILITY

The mating surfaces provide a gas-tight connection and resists corrosion caused by adverse environments. This seal is made possible by the spring-like properties of the Varicon contact and by the smoothness of the coined mating surfaces. After being mated for years, the contacts still retain clean, unoxidized mating surfaces.

LOW RESISTANCE

Because of the spring-like properties of the Varicon contact, both sides of the contact are always under considerable pressure when mated. Their sliding and wiping action burnishes the surfaces in a self-cleaning action reducing any constrictive resistance. The low contact resistance remains a permanent feature of the Varicon contact even after thousands of mating and unmating cycles.

HIGH CURRENT CAPACITY

The low contact resistance contributes substantially to Varicon's high current-carrying capacitor. Also, its heat-dissipating characteristics are enhanced by its flat configuration.



SHOCK AND VIBRATION RESISTANCE

Should external forces cause any decrease in contact pressure between two of the four mating surfaces, it is automatically compensated by redistributing the contact pressure between the other two mating surfaces.

ECONOMY

Varicon contacts are stamped from sheet stock instead of screw-machined. Consequently, this production method not only increases the production capacity but decreases production cost as there is little waste.

VERSATILITY

The Varicon concept can be used in a card-mounted plug that mates with a receptacle, or Varicon contacts can be staked directly to a pc board and soldered into place. This latter method eliminates the need for a conventional plug reducing the cost of the connection system while retaining the proven reliability of the Varicon interconnection.

CONTACT TYPES

Two basic sizes of our Varicon contact are available: standard and miniature Varicon. And each size has two major variations: the fixed Varicon contact and the Varilok insertable / removable version. The standard size is rated at 8 amps and has a withdrawal force range of 2 to 16 ounces per contact. The miniature size is specifically for high density applications and is rated at 5 amps with a withdrawal force of 2 to 8 ounces per contact. (For exact specifications, check the individual series listing.)



Miniature Varicon®

Approx. 2X Actual Size



Standard Varicon®

Introduction

CONTACT MATERIAL

The primary contact material used is phosphor bronze. The electrical conductivity of copper alloys are extremely good. Within the Varicon concept, the contacts must also perform as springs and these alloys offer the elastic properties and the endurance required by today's rugged applications.

CONTACT PLATING

A nickel underplate of 50 to 100 microinches, followed by a minimum of 10 microinches of gold plate is Elco's standard contact plating. The gold plate prevents the formation of insulating oxide films while the nickel plate provides a hard backing. It, in turn, reduces wear on the gold and prevents diffusion between the gold and base metal. Other plating thicknesses, such as those required by military specifications, can be supplied on request.

VARILOK CRIMP-AND-INSERT CONTACTS

The crimp-termination, insertable / removable Varilok contact offers a solderless connection between wire and contact as well as strain relief for the wire. This contact snaps into the insulator quickly and easily. With our simple tool it can be removed without difficulty, yet it locks securely into place and cannot twist or bend out of alignment.



Loose Varilok Contacts



Reel-Mounted Varilok Contacts

Varilok contacts also are available with wire-wrappable, solder and taper-tab tail configurations. Available loose for small scale production and replacement purposes, the Varilok contact is also supplied on reels for use with fast, economical automatic crimping machines reducing man-hour requirements and production costs in medium and large-scale production runs. Because the contact can be crimped to the wire and installed into the insulator at any point during the manufacturing operation, it offers the user convenience and flexibility. Reels contain 1800 standard contacts or 3000 miniature contacts.

Introduction

MINI-VARILOK

The Mini-Varilok is half the size of the standard Varilok contact. It's designed for hand or machine crimping to solid or stranded AWG #22 to #30 wire. Its basic features are identical to the standard Varilok however it also incorporates a decreased insertion force and is used for high density applications. Production methods for the Mini-Varilok are the same as the standard Varilok.

CONTACT RETENTION

The Varilok contact, after undergoing five insertion / extraction cycles and being subjected to the vibration and shock tests of MIL-C-28731, still withstands an axial load in excess of 10 pounds (6 for mini-varilok).

WIRE SIZE

The Varilok contact with its open crimp barrel conforms to practically all specifications written for screw-machined contacts with closed crimp barrels. The crimp barrel of the Varilok contact is designed to accommodate wire sizes AWG #18 to #26. It's also possible to crimp together two stranded #22 or smaller wires. The Mini-Varilok accommodates wire sizes AWG #22 to #30. Table I lists the various sizes of wire to which Varilok contacts can be crimped, and indicates the minimum conductor diameter and the maximum insulator diameter that can be accommodated by the contacts. The crimp barrel is also crimped to the wire's insulation for strain relief and the large, overlapping ears of the barrel accommodate a wide range of wire insulation sizes (Table I). For an optimum crimp connection, the insulation is stripped one-eighth inch from the end of the conductor.

**Table I
Wire Sizes
(AWG)**

(Ref: MIL-W-16878/4 – Type E wire)

Single Wire	Varilok	Mini-Varilok	Conductor Diameter (Nominal)	Insulator Diameter (Max. Overall)
#18	Yes	No	.048	.074
#20	Yes	No	.038	.062
#22	Yes	Yes	.030	.054
#24	Yes	Yes	.024	.048
#26	Yes	Yes	.019	.043
#28	No	Yes	.015	.039
#30 (Stranded)	No	Yes	.012	.036

CRIMP CHARACTERISTICS

The illustration shows an enlarged cross-section of a typical Varilok crimp on a #22 stranded wire. No significant voids are visible. The complete deformation of the wire strands indicates optimum contact between the contact barrel and the conductors.

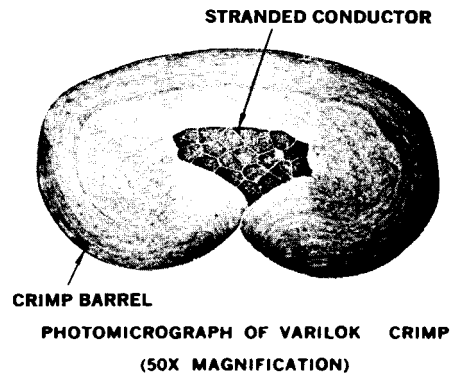

TENSILE STRENGTH

Table II lists the values, in pounds, of tensile strength (wire pull-out force) for Varilok and Mini-Varilok contacts crimped to stranded AWG #18 to #30 wires.

**Table II
Tensile Strength
(In Pounds)**

Wire Size (AWG)	#18	#20	#22	#24	#26	#28	#30
Stranded Wire	40	25	15	10	5	3	1.5

CRIMPING EQUIPMENT

All equipment needed to crimp Varilok and Mini-Varilok contacts is normally available from stock. Crimping equipment for production crimping as well as hand-operated crimping pliers are designed to realize the full electrical, mechanical and economical advantages of the Varilok and Mini-Varilok contact.

Series 8014

Elco has introduced a new, metric version of the famous Varicon connector. The wire to board 8014 series is available in 50 or 64 positions and suitable for use in a VME front plate.

The Varicon contact is well known for high reliability and durability under all conditions. Contacts are specified at 2 amps and low contact resistance. In the 8014 series, the familiar hermaphroditic contact is shrouded on both sides to protect and guide the contact to a perfect mating. Board termination is right angle or vertical to plated through holes. The connectors have actuating screws to assist mating and unmating and to provide secure attachment. The covers have integral cable clamps. The 50 position cover is plastic and 64 position is die cast aluminum.

TECHNICAL SPECIFICATIONS

Number of Contacts: 50, 64	Dielectric Withstanding Voltage: 2000V rms/min.
Contact Spacing: 4.0mm	Durability: 200 cycle
Current Rating: 2Amp/pin	Applicable Wire Size: AWG #18~#26
Voltage Rating: 125V	Operating Temperature: -55~+105°C

MATERIAL / FINISH

Insulator: Plug PBT Rec. PBT	Hardware: see individual drawing
Contact: Phosphor Bronze Finish / Gold over Nickel	

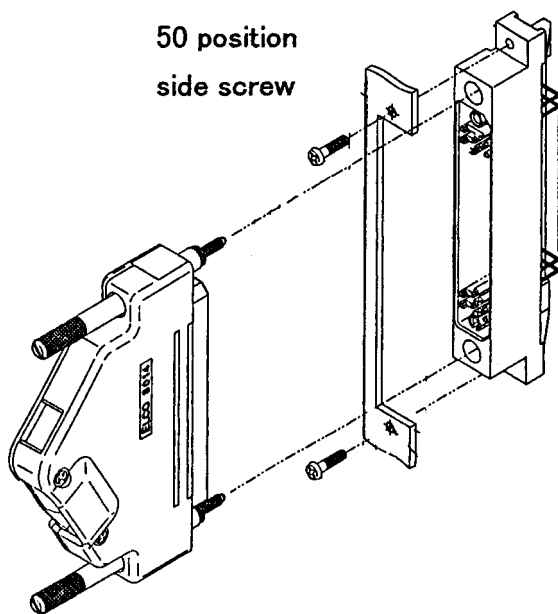

64 position
center screw
EMI shield

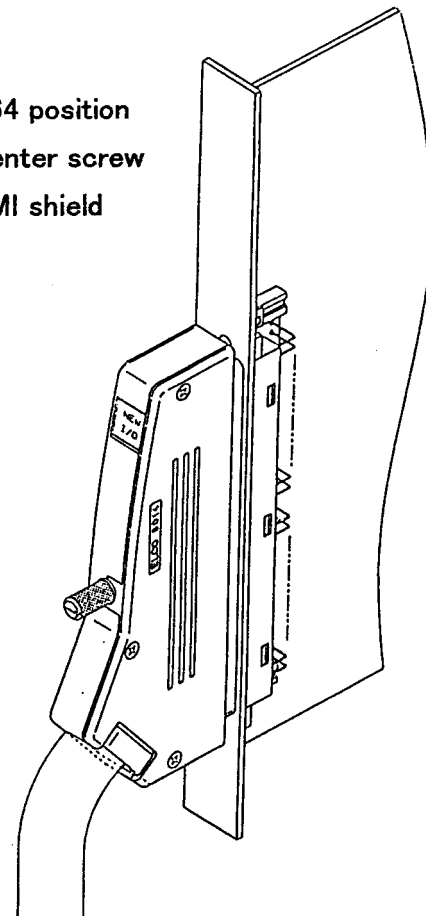

ORDERING CODE (64 pos. Center-Screw Type Plug)

10

8014

264

XXX

XXX

Variation 1 / Contact Code

- 000 = No contact loaded
- 100 = Wire crimp contact (loose pieces attached)
- 200 = Straight through hole

Variation 2 / Finish, Color

- 000 = without cover, center-screw, green insulator
- 100 = with cover, center-screw, green insulator

10 8014 264 100 100

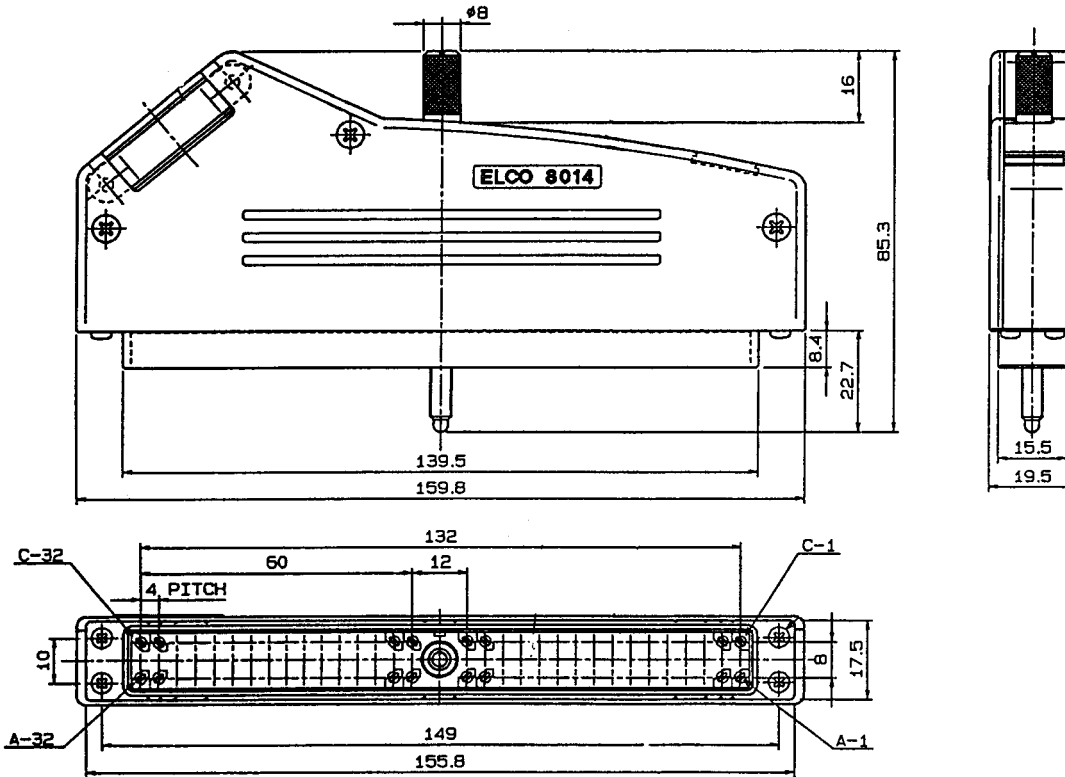

10 8014 264 200 000

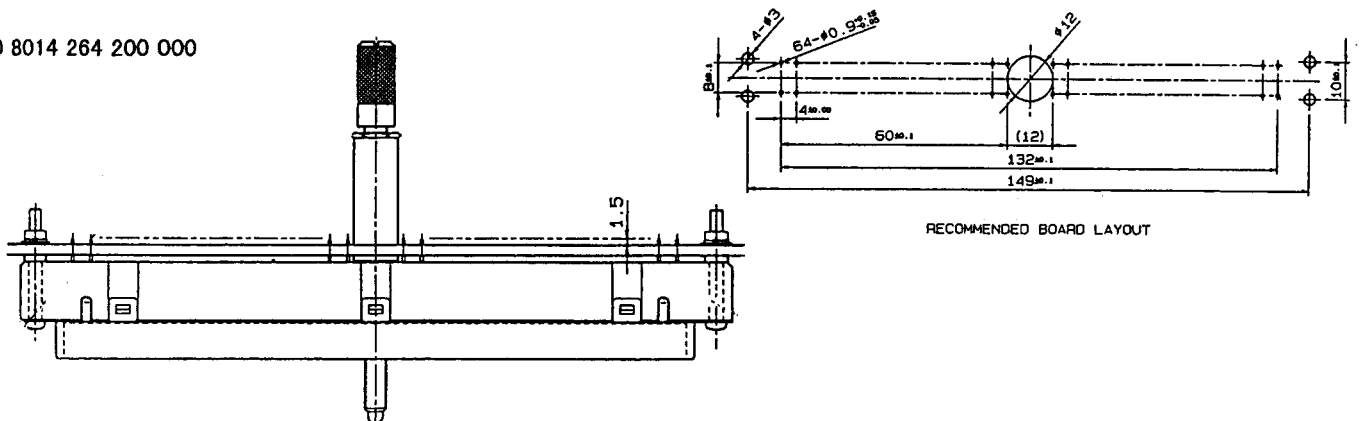

ORDERING CODE (64 pos. Center-Screw Type Receptacle)

20

8014

264

XXX

XXX

Variation 1 / Contact Code

- 000 = No contact loaded
- 100 = Wire crimp contact (loose pieces attached)
- 200 = Straight through hole
- 999 = Right angle through hole

Variation 2 / Finish, Color

- 000 = R/A through hole, center lock nut, green insulator
- 100 = ST through hole, center lock nut, green insulator

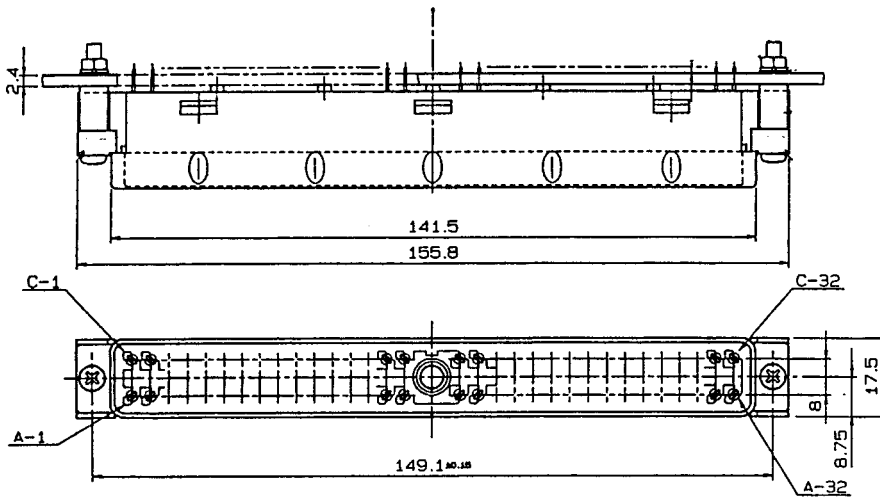

20 8014 264 200 100

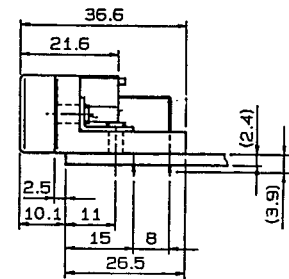
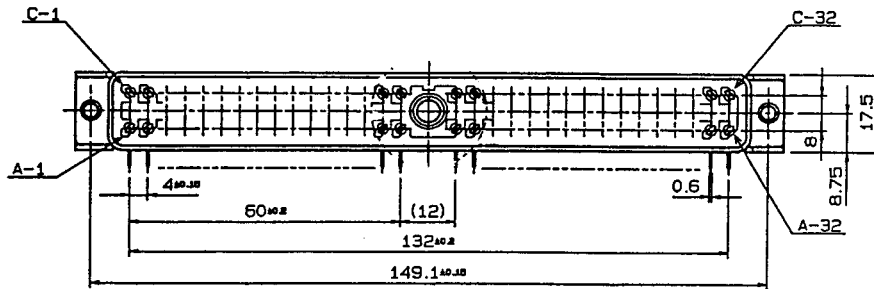
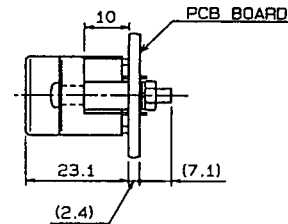

20 8014 264 999 000

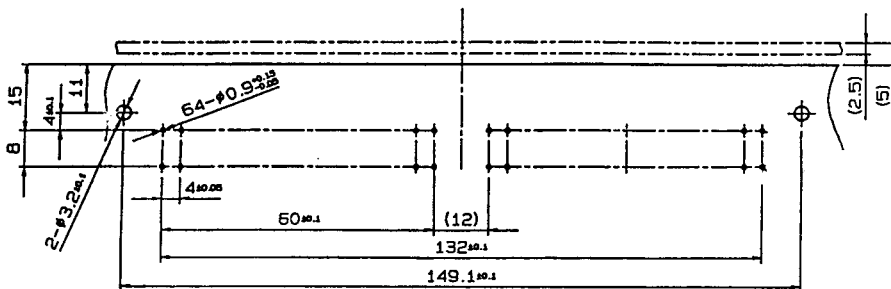

RECOMMENDED BOARD LAYOUT t=2.4

ORDERING CODE (50 pos. Side-Screw, Plug)

10

8014

350

XXX

XXX

Variation 1 / Contact Code

- 000 = No contact loaded
- 100 = Wire crimp contact (loose pieces attached)
- 200 = Straight through hole

Variation 2 / Finish, Color

- 028 = Side-screw, gray insulator
- 128 = Side-screw, gray insulator with cover
- (038 = Side-short-screw, gray insulator. . . . special)

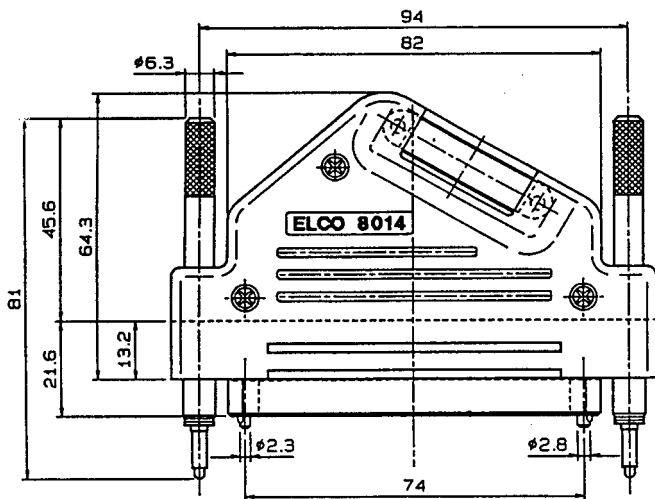

10 8014 350 100 128

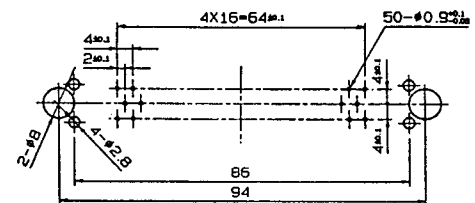
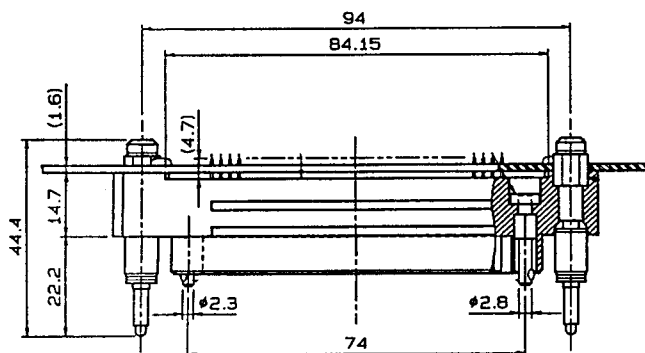
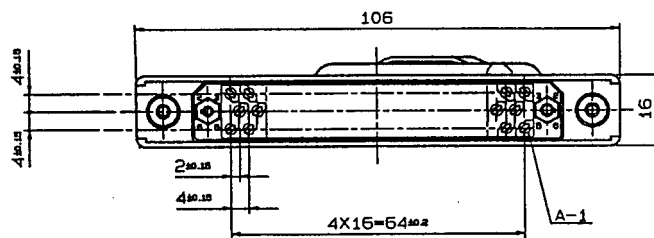
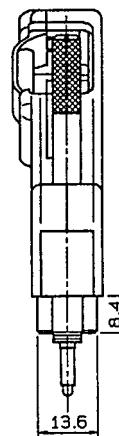

RECOMMENDED BOARD LAYOUT

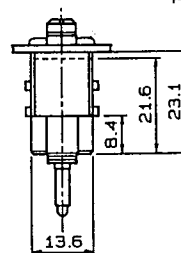

10 8014 350 200 038

ORDERING CODE (50 pos. Side-Screw Receptacle)

20

8014

350

999

028

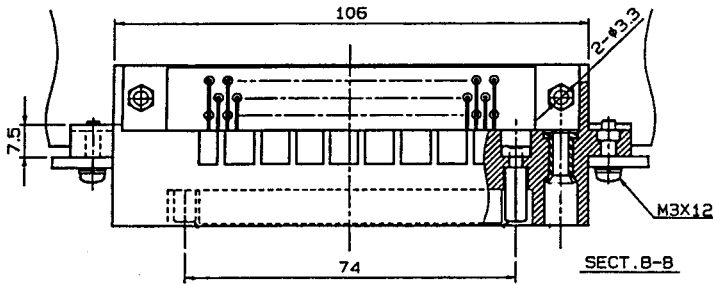

Variation 1 / Contact Code
999 = Right angle through hole

Variation 2 / Finish, Color
028 = Side-screw, gray insulator

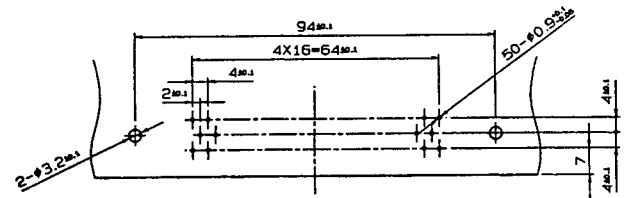

RECOMMENDED BOARD LAYOUT

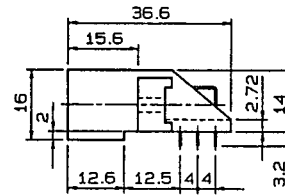
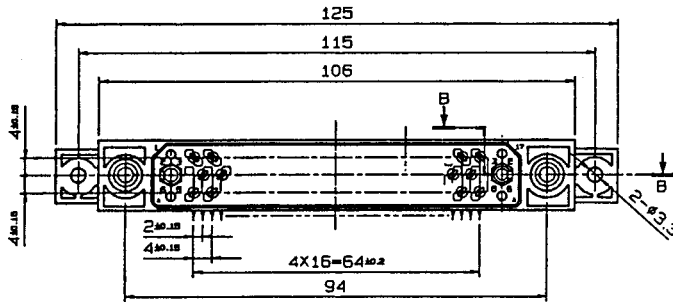

ORDERING CODE (Crimp Contact)

70

8014

000

000

858

Finish Code
858 = 10 microinches Gold over Nickel Plate

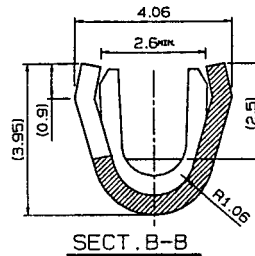
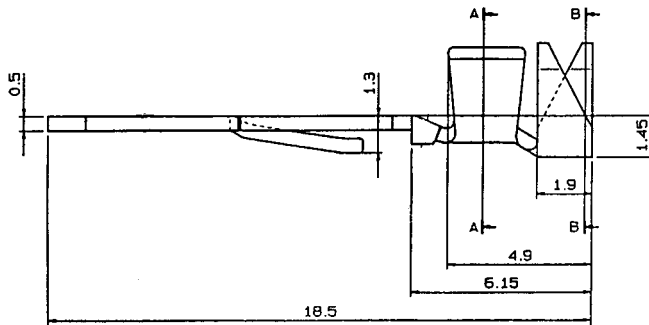
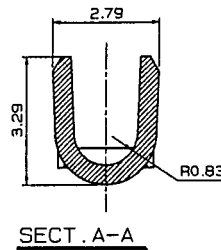
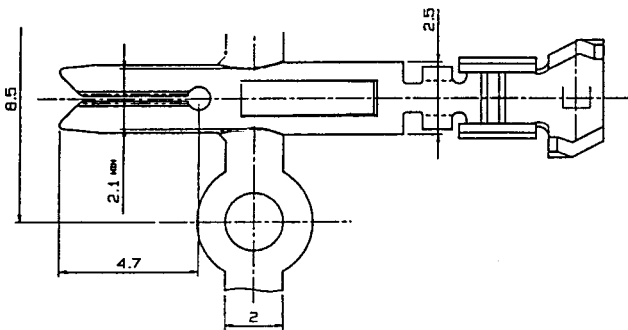

ORDERING CODE (Cover, 64 pos. Center-Screw, Aluminum Die Cast)

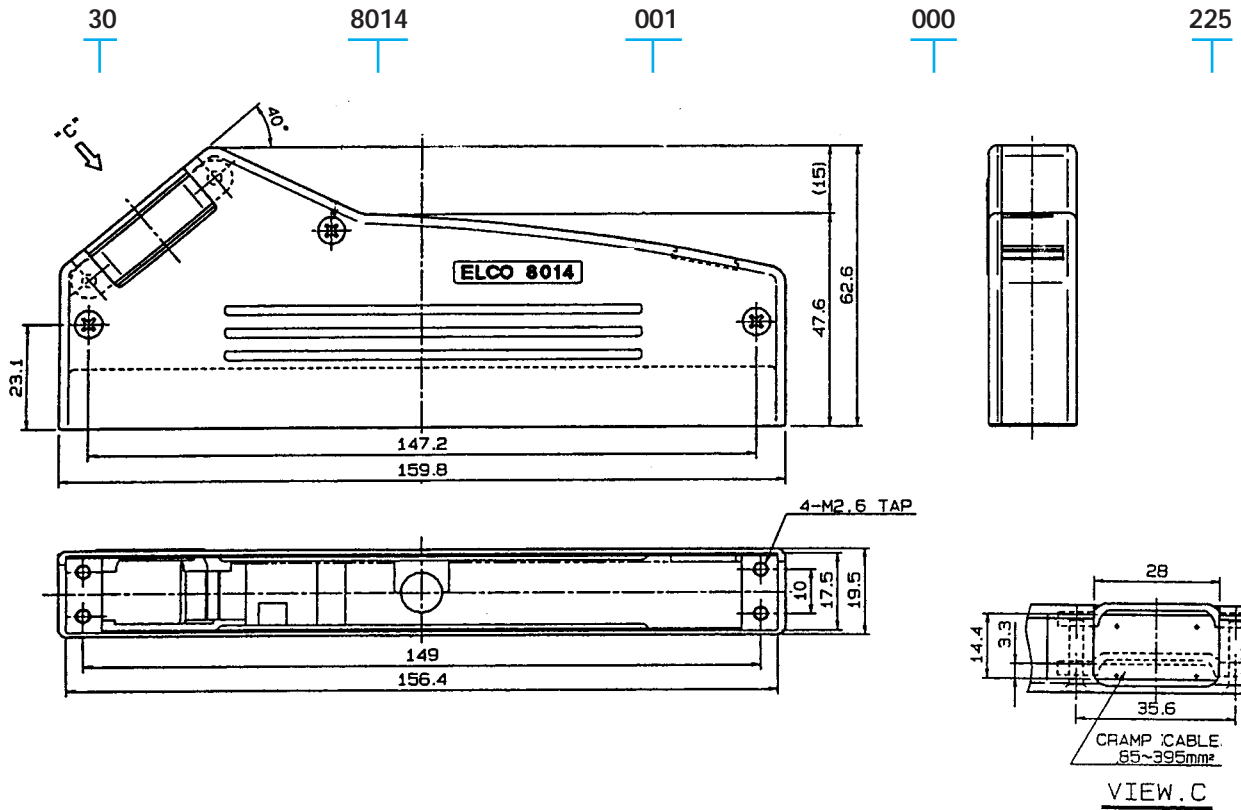

ORDERING CODE (50 pos. Side-Screw, Plastic (gray))

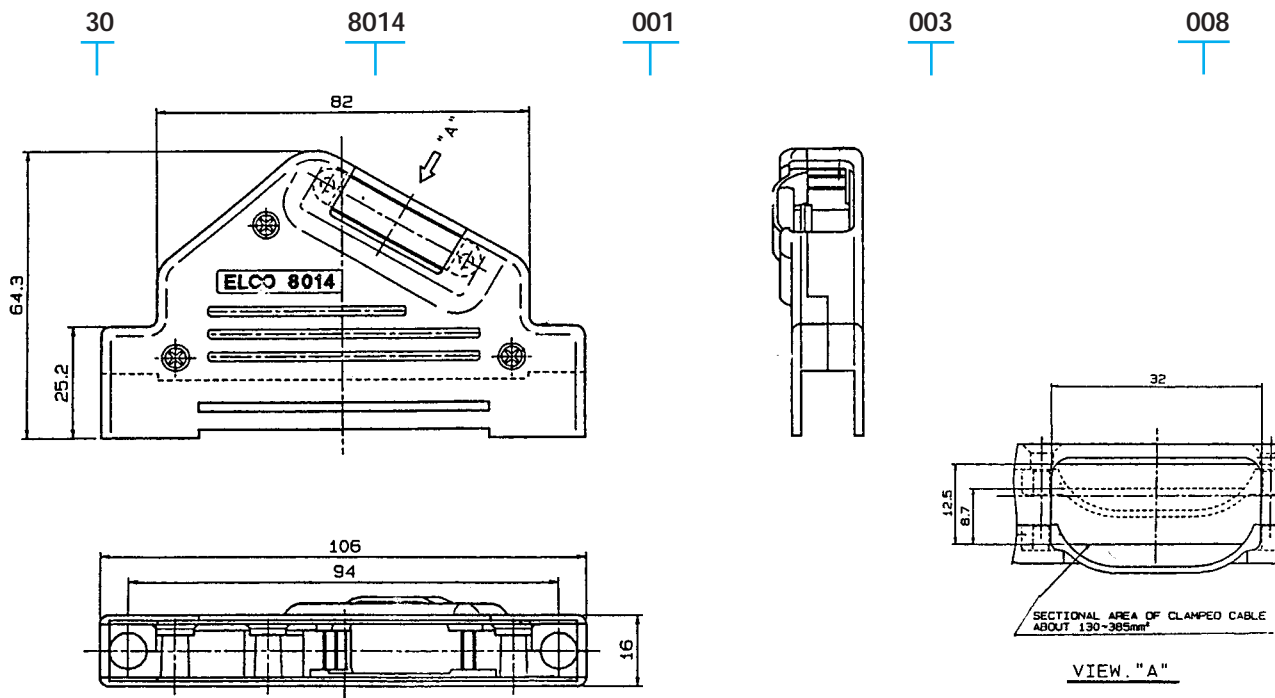

Series 8016 – Rectangular Connector – 20 Way

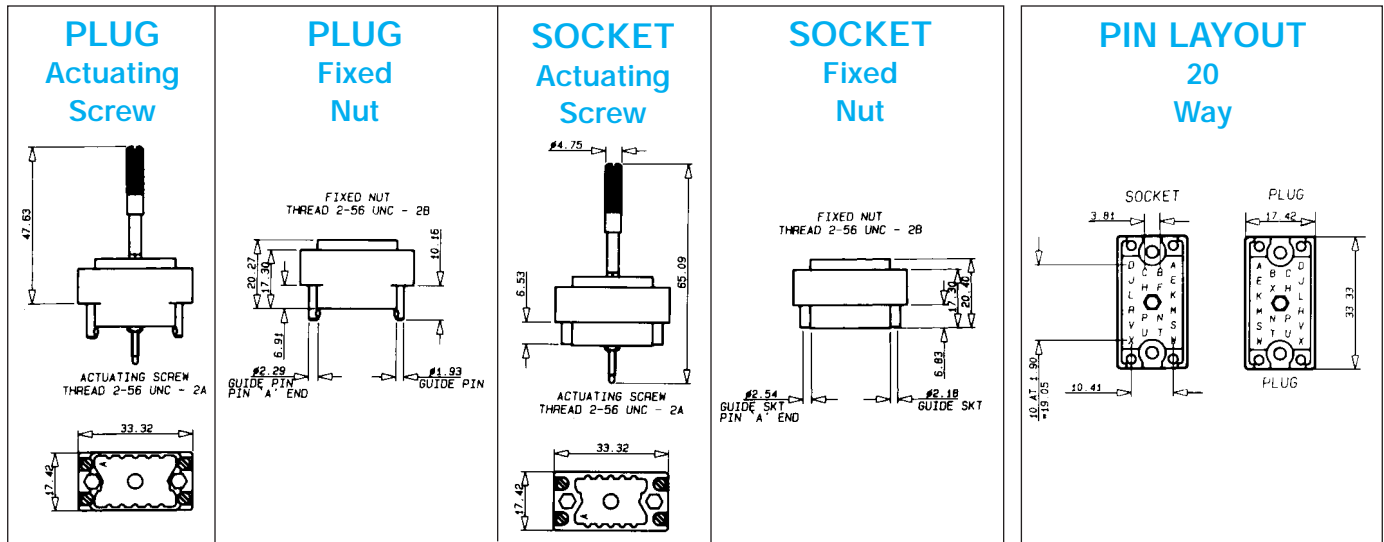

ORDERING CODE



Contact Termination

*000 = Contacts not fitted and ordered separately, see page 22 for full list of options

217 = Solder 0.098" x 2.49mm

218 = Wire Wrap –
0.025 x 0.050 x 0.567" / 0.64 x 1.27 x 14.4mm

296 = Wire Wrap –
0.025 x 0.026 x 0.579" / 0.64 x 1.27 x 19.3mm

504 = Solder Tail –

750 = Wire Wrap –
0.025 x 0.050 x 0.760" / 0.64 x 1.27 x 19.3mm

*Crimp contacts always ordered separately. See page 22 for details.

CONNECTOR PLUG AND RECEPTACLE COMBINATIONS

Plug	Receptacle	007/507/607	008/508/608			909/509/609	910/510/610	911/511/611	912/512/612		
		001/501/601	<input checked="" type="checkbox"/>								
002/502/602		<input checked="" type="checkbox"/>									
903/503/603		<input checked="" type="checkbox"/>									
904/504/604		<input checked="" type="checkbox"/>									
905/505/605			<input checked="" type="checkbox"/>								
906/506/606			<input checked="" type="checkbox"/>								

Select variation code combinations marked with square in the table.

VARIATION CODE

Insulator Body Type	European Version		USA Versions				Cover and Cable Entrance	Actuating Screw	Fixed Nut
	Grey Polyester		Grey Polyester		Green Polyester				
	Aluminum Cover	No Cover	Cover	No Cover	Cover	No Cover			
Male (Exposed Contacts)	—	001	—	501	—	601	None	Yes	No
	903	002	—	502	—	602	None	No	Yes
	904	—	503	—	603	—	Top*	Yes	No
	905	—	504	—	604	—	Side*	Yes	No
	906	—	505	—	605	—	Top*	No	Yes
Female (Recessed Contacts)	—	007	—	507	—	607	None	No	Yes
	909	008	—	508	—	608	None	Yes	No
	910	—	509	—	609	—	Top*	Yes	No
	911	—	510	—	610	—	Side*	Yes	No
	912	—	511	—	611	—	Top*	No	Yes
	—	—	512	—	612	—	Side*	No	Yes

*These covers should only be used with crimp contacts.

Series 8016 – Rectangular Connector – 20 Way

CLAMPING AND COVER DIMENSIONS

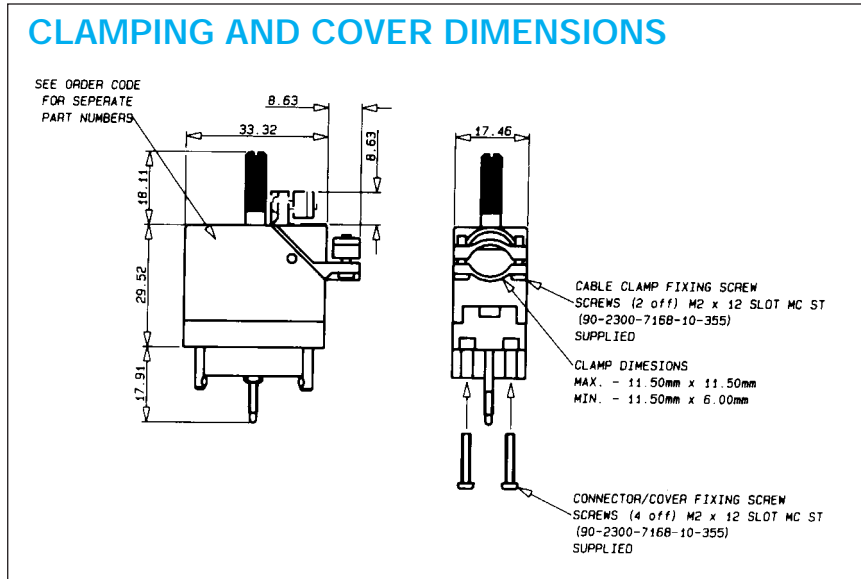

RECOMMENDED LAYOUT FOR FRONT CHASSIS MOUNTING

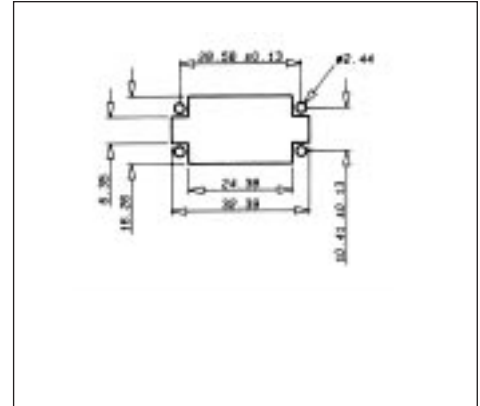

STANDARD COVERS

Cover Part Number		Number of Contacts	Cable Entrance	Clamp	
European Version	USA Version			Description	Size mm (inches)
30-8016-9829-20-000	30-8016-9829-00-0000	20	Side	Standard	11.53 (0.454) Dia.
30-8016-9831-20-000	30-8016-9831-00-0000	20	Top	Standard	11.53 (0.454) Dia.

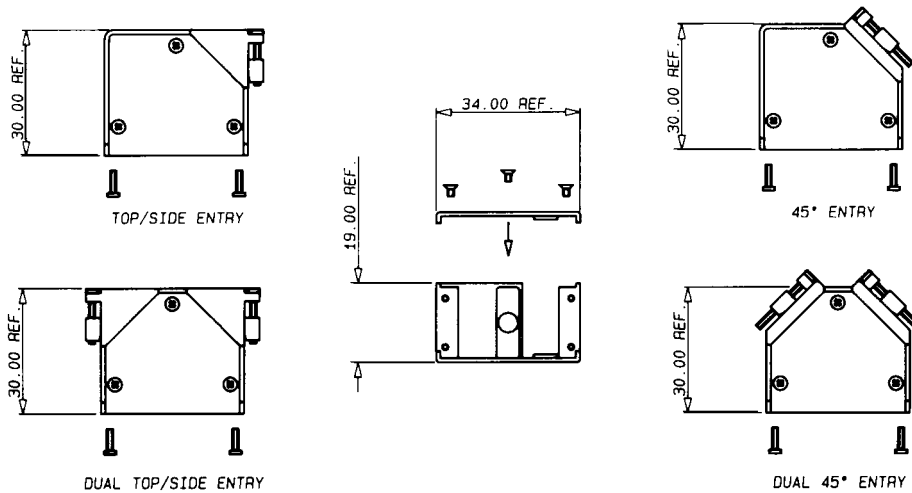

REMOVABLE SIDE PLATE COVERS

millimeters (inches)

Cover Part Number	Number of Contacts	Cable Entrance	Clamp		
			Description	Minimum Size	Maximum Size
30-8016-020-000-413	20	Side/Top	Standard	5 x 10 (0.197 x 0.394)	10 x 10 (0.394 x 0.394)
30-8016-020-000-415	20	45°	Standard	5 x 10 (0.197 x 0.394)	10 x 10 (0.394 x 0.394)
30-8016-020-000-423	20	Dual 90° Side/Top	Special	2 - 5 x 10 (0.197 x 0.394)	2 - 10 x 10 (0.394 x 0.394)
30-8016-020-000-425	20	Dual 45° Entry	Special	2 - 5 x 10 (0.197 x 0.394)	2 - 10 x 10 (0.394 x 0.394)

Series 8016 – Rectangular Connector – 38 Way

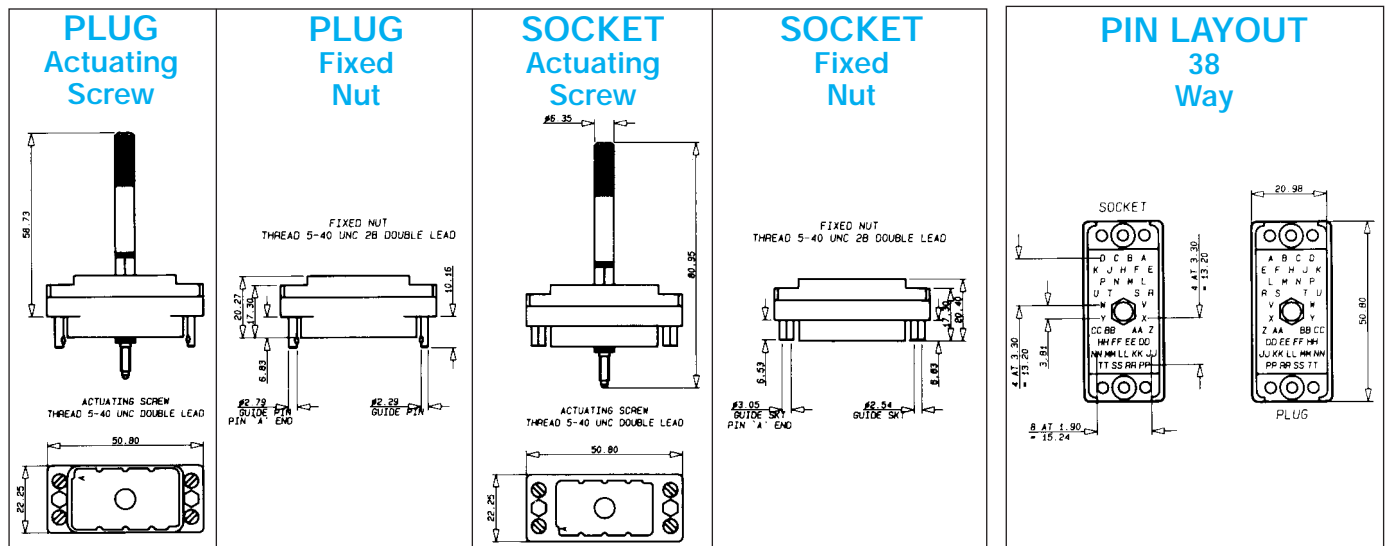

ORDERING CODE



Contact Termination	
*000 = Contacts not fitted and ordered separately, see page 22 for full list of options	
217 = Solder 0.098" x 2.49mm	
218 = Wire Wrap – 0.025 x 0.050 x 0.567" / 0.64 x 1.27 x 14.4mm	
296 = Wire Wrap – 0.025 x 0.026 x 0.579" / 0.64 x 1.27 x 19.3mm	
504 = Solder Tail –	
750 = Wire Wrap – 0.025 x 0.050 x 0.760" / 0.64 x 1.27 x 19.3mm	

*Crimp contacts always ordered separately. See page 22 for details.

CONNECTOR PLUG AND RECEPTACLE COMBINATIONS

Plug	Receptacle													
	007/507/607	008/508/608	909/509/609	910/510/610	911/511/611	912/512/612	923/523/623	924/524/624	925/525/625	926/526/626	935/535/635	936/536/636	937/537/637	938/538/638
001/501/601														
002/502/602														
903/503/603														
904/504/604														
905/505/605														
906/506/606														
919/519/619														
920/520/620														
921/521/621														
922/522/622														
931/531/631														
932/532/632														
933/533/633														
934/534/634														

Select variation code combinations marked with square in the table.

VARIATION CODE

Insulator Body Type	European Version				USA ONLY Versions								Cover & Cable Entrance	Actuating Screw	Fixed Nut
	Grey Polyester				Grey Polyester				Green Polyester						
	Aluminum Cover		No Cover		Aluminum Cover		No Cover		Aluminum Cover		No Cover				
Male (Exposed Contacts)	Std. Clamp	Large Clamp	Ex-Large Clamp	001	Std. Clamp	Large Clamp	Ex-Large Clamp	501	Std. Clamp	Large Clamp	Ex-Large Clamp	601	None	Yes	No
	—	—	—	002	—	—	—	502	—	—	—	602			
	903	919	931	—	503	519	531	—	603	619	631	—			
	904	920	932	—	504	520	532	—	604	620	632	—			
	905	921	933	—	505	521	533	—	605	621	633	—			
	906	922	934	—	506	522	534	—	606	622	634	—			
Female (Recessed Contacts)	—	—	—	007	—	—	—	507	—	—	—	607	None	No	Yes
	—	—	—	008	—	—	—	508	—	—	—	608			
	909	923	935	—	509	523	535	—	609	623	635	—			
	910	924	936	—	510	524	536	—	610	624	636	—			
	911	925	937	—	511	525	537	—	611	625	637	—			
	912	926	938	—	512	526	538	—	612	626	638	—			

CLAMPING AND COVER DIMENSIONS

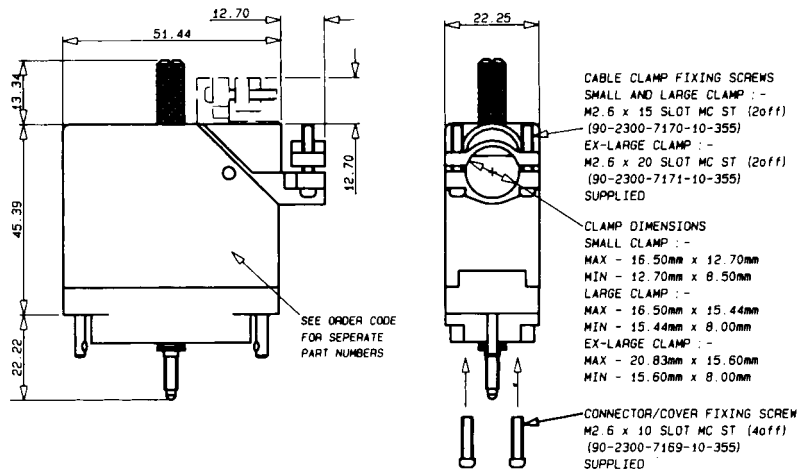

RECOMMENDED LAYOUT FOR FRONT CHASSIS MOUNTING

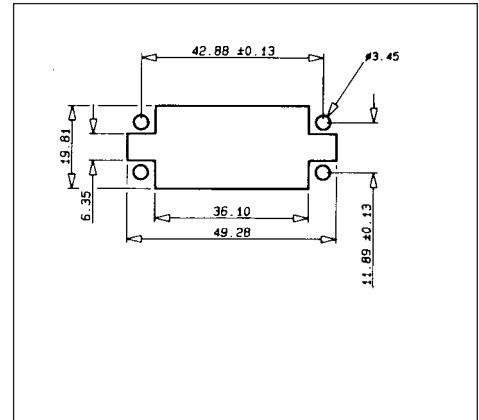

STANDARD COVERS

European Version	Cover Part Number	USA Version	Number of Contacts	Cable Entrance	Clamp	
					Description	Size mm (inches)
	30-8016-9821-20-000	30-8016-9821-00-0000	38	Side	Standard	16.51 X 12.70 (0.650 x 0.500)
	30-8016-9822-20-000	30-8016-9822-00-0000	38	Top	Standard	16.51 X 12.70 (0.650 x 0.500)
	30-8016-9825-20-000	30-8016-9825-00-0000	38	Side	Large	16.51 X 15.44 (0.650 x 0.608)
	30-8016-9826-20-000	30-8016-9826-00-0000	38	Top	Large	16.51 X 15.44 (0.650 x 0.608)
	30-8016-9838-20-000	30-8016-9838-00-0000	38	Side	Extra-Large	20.83 X 15.60 (0.820 x 0.614)
	30-8016-9839-20-000	30-8016-9839-00-0000	38	Top	Extra-Large	20.83 X 15.60 (0.820 x 0.614)

OPTIONAL REMOVABLE SIDE PLATE COVER

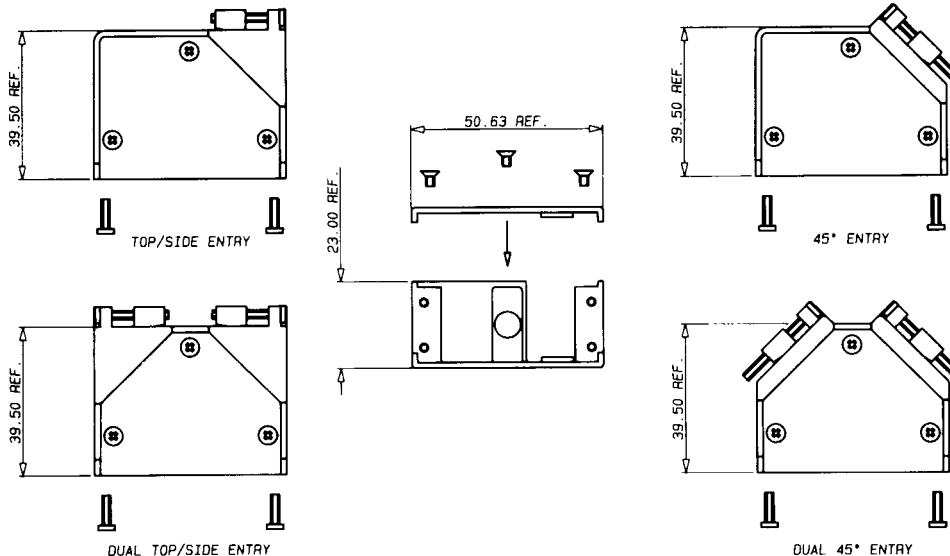

REMOVABLE SIDE PLATE ENTRY COVERS

millimeters (inches)

Cover Part Number	Number of Contacts	Cable Entrance	Description	Clamp	
				Minimum Size	Maximum Size
30-8016-038-000-413	38	Side/Top	Standard	6 x 14 (0.236 x 0.551)	17 x 14 (0.669 x 0.551)
30-8016-038-000-415	38	45°	Standard	6 x 14 (0.236 x 0.551)	17 x 14 (0.669 x 0.551)
30-8016-038-000-423	38	Dual 90° Side/Top	Special	2 - 6 x 14 (0.236 x 0.551)	2 - 17 x 14 (0.669 x 0.551)
30-8016-038-000-425	38	Dual 45° Entry	Special	2 - 6 x 14 (0.236 x 0.551)	2 - 17 x 14 (0.669 x 0.551)

Series 8016 – Rectangular Connector – 56 Way

CLAMPING AND COVER DIMENSIONS

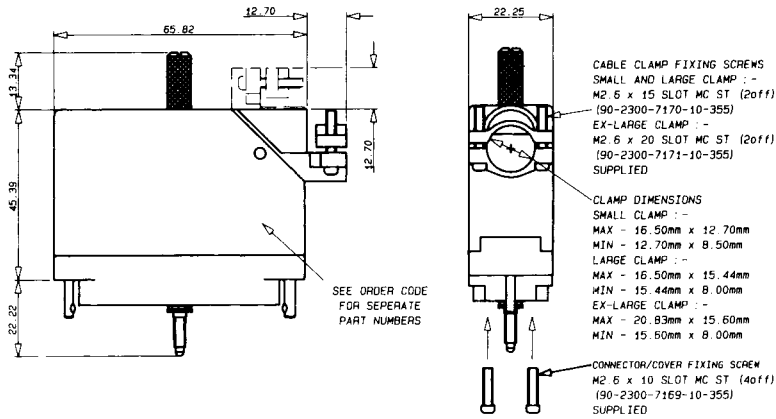

RECOMMENDED LAYOUT FOR FRONT CHASSIS MOUNTING

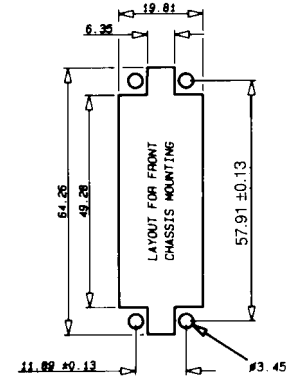

STANDARD COVERS

European Version	Cover Part Number	USA Version	Number of Contacts	Cable Entrance	Clamp	
					Description	Size mm (inches)
	30-8016-9823-20-000	30-8016-9823-00-0000	56	Side	Standard	16.51 X 12.70 (0.650 x 0.500)
	30-8016-9824-20-000	30-8016-9824-00-0000	56	Top	Standard	16.51 X 12.70 (0.650 x 0.500)
	30-8016-9827-20-000	30-8016-9827-00-0000	56	Side	Large	16.51 X 15.44 (0.650 x 0.608)
	30-8016-9828-20-000	30-8016-9828-00-0000	56	Top	Large	16.51 X 15.44 (0.650 x 0.608)
	30-8016-9840-20-000	30-8016-9840-00-0000	56	Side	Extra-Large	20.83 X 15.60 (0.820 x 0.614)
	30-8016-9842-20-000	30-8016-9842-00-0000	56	Top	Extra-Large	20.83 X 15.60 (0.820 x 0.614)

OPTIONAL REMOVABLE SIDE PLATE COVER

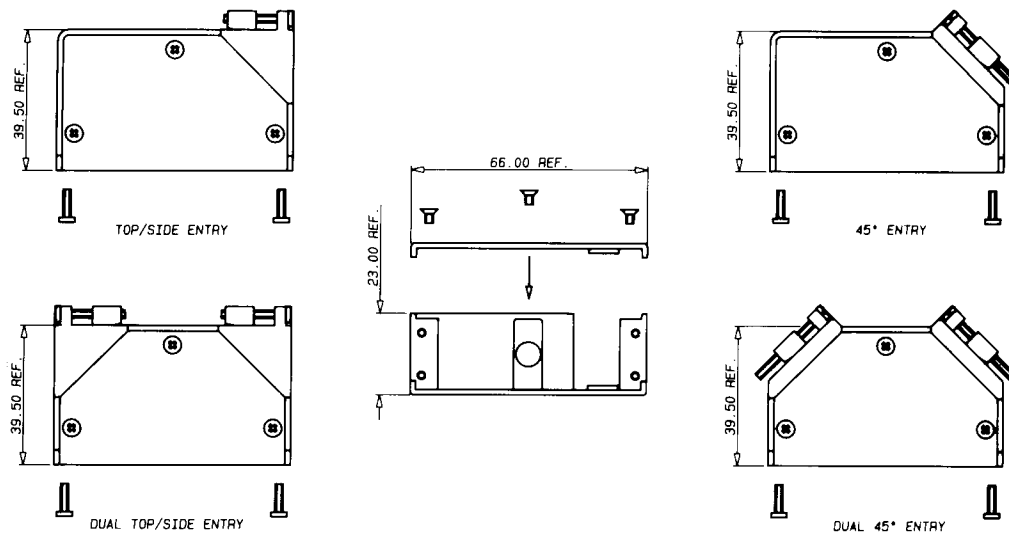

REMOVABLE SIDE PLATE COVERS

millimeters (inches)

Cover Part Number	Number of Contacts	Cable Entrance	Description	Clamp	
				Minimum Size	Maximum Size
30-8016-056-000-413	56	Side/Top	Standard	6 x 14 (0.236 x 0.551)	17 x 14 (0.669 x 0.551)
30-8016-056-000-415	56	45°	Standard	6 x 14 (0.236 x 0.551)	17 x 14 (0.669 x 0.551)
30-8016-056-000-423	56	Dual 90° Side/Top	Special	2 - 6 x 14 (0.236 x 0.551)	2 - 17 x 14 (0.669 x 0.551)
30-8016-056-000-425	56	Dual 45° Entry	Special	2 - 6 x 14 (0.236 x 0.551)	2 - 17 x 14 (0.669 x 0.551)

Series 8016 – Rectangular Connector – 90 Way

CLAMPING AND COVER DIMENSIONS

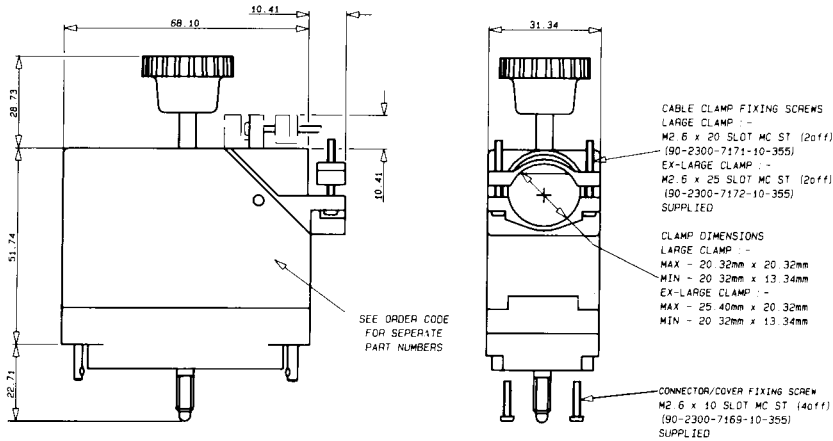

RECOMMENDED LAYOUT FOR FRONT CHASSIS MOUNTING

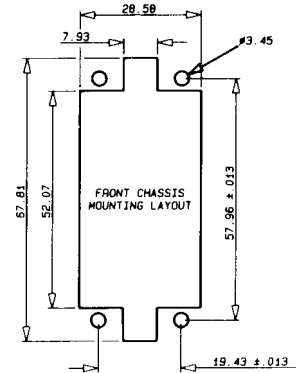

STANDARD COVERS

Cover Part Number		Number of Contacts	Cable Entrance	Clamp	
European Version	USA Version			Description	Size mm (inches)
30-8016-9832-20-000	30-8016-9832-00-0000	90	Side	Large	20.32 (0.800) Dia.
30-8016-9833-20-000	30-8016-9833-00-0000	90	Top	Large	20.32 (0.800) Dia.
30-8016-9843-20-000	30-8016-9843-00-0000	90	Side	Extra-Large	25.40 x 20.32 (1.00 x 0.008)
30-8016-9844-20-000	30-8016-9844-00-0000	90	Top	Extra-Large	25.40 x 20.32 (1.00 x 0.008)

OPTIONAL REMOVABLE SIDE PLATE COVER

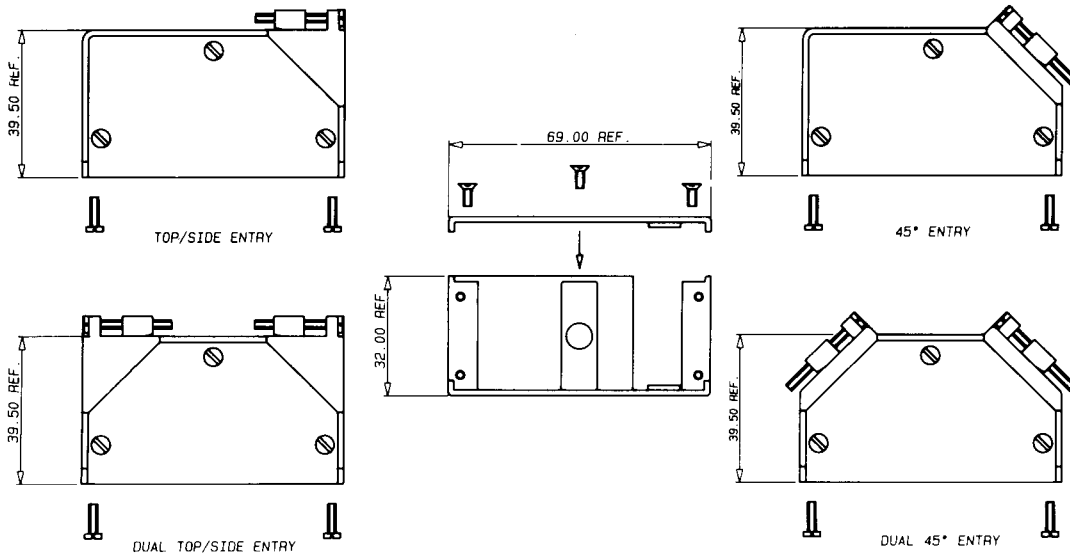

REMOVABLE SIDE PLATE COVERS

millimeters (inches)

Cover Part Number	Number of Contacts	Cable Entrance	Clamp		
			Description	Minimum Size	Maximum Size
30-8016-090-000-413	90	Side/Top	Standard	7 x 21 (0.276)	21 x 21 (0.827 x 0.827)
30-8016-090-000-415	90	45°	Standard	7 x 21 (0.276)	21 x 21 (0.827 x 0.827)
30-8016-090-000-423	90	Dual 90° Side/Top	Special	2 - 7 x 21 (0.276)	2 - 21 x 21 (0.827 x 0.827)
30-8016-090-000-425	90	Dual 45° Entry	Special	2 - 7 x 21 (0.276)	2 - 21 x 21 (0.827 x 0.827)

Series 8016 – Rectangular Connector – 120 Way

CLAMPING AND COVER DIMENSIONS

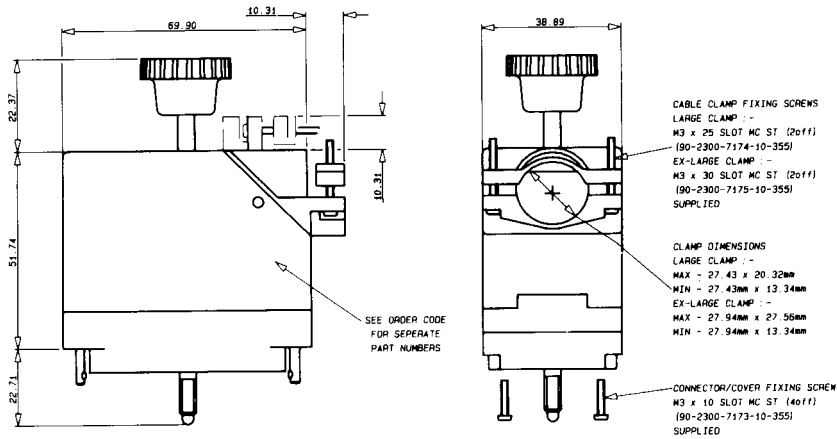

RECOMMENDED LAYOUT FOR FRONT CHASSIS MOUNTING

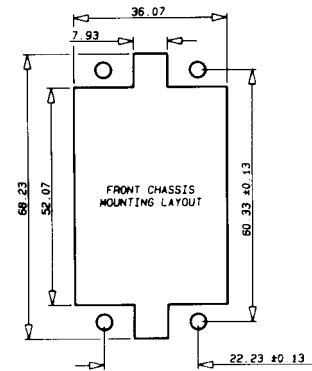

STANDARD COVERS

Cover Part Number		Number of Contacts	Cable Entrance	Clamp	
European Version	USA Version			Description	Size mm (inches)
30-8016-9834-20-000	30-8016-9834-00-0000	120	Side	Large	20.32 x 27.43 (0.800 x 1.080)
30-8016-9835-20-000	30-8016-9835-00-0000	120	Top	Large	20.32 x 27.43 (0.800 x 1.080)
30-8016-9845-20-000	30-8016-9845-00-0000	120	Side	Extra-Large	27.94 x 27.56 (1.100 x 1.085)
30-8016-9846-20-000	30-8016-9846-00-0000	120	Top	Extra-Large	27.94 x 27.56 (1.100 x 1.085)

NB: There are no removable side plate covers for the 120 Way version.

Loose Contacts

Varilok® connectors can be specified as either fully loaded, to include the connector body and a variety of pre-loaded contact termination types or the empty body and a selection

of separately specified and ordered contacts. The table below details the various loose contacts available.

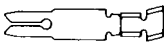
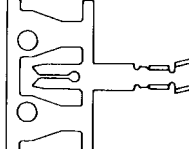
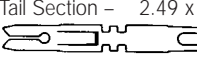
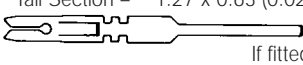
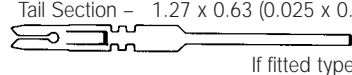
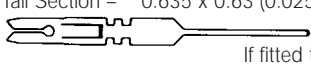
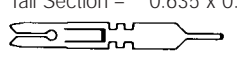
Contact Style	Description	Plating Specification	Order Code
 * Ordered separately	Crimp Contact Loose	0.25µM Gold All Over (Standard) 0.25µM Gold Nose & Tail (Optional)	60 8017 0313 00 339 60 8017 0313 00 042
 * Ordered separately	Crimp Contact End Carrier (1800 Contacts per reel)	0.25µM Gold All Over (Standard) 0.25µM Gold Nose & Tail (Optional) 0.25µM Gold All Over (Standard) 0.25µM Gold Nose & Tail (Optional)	60 8017 0323 99 339 60 8017 0323 99 042 60 8017 0323 00 339** 60 8017 0323 00 042**
 * Tail Section – 2.49 x 0.61 (0.098 x 0.024) If fitted type 217	Solder Tag Contact	0.25µM Gold All Over (Standard)	60 8017 0513 00 339
 * Tail Section – 1.27 x 0.63 (0.025 x 0.005) If fitted type 218	14.4mm Maxiwrap Contact	0.25µM Gold All Over (Standard)	60 8017 0613 00 339
 * Tail Section – 1.27 x 0.63 (0.025 x 0.005) If fitted type 750	19.3mm Maxiwrap Contact	0.25µM Gold All Over (Standard)	60 8017 0623 00 339
 * Tail Section – 0.635 x 0.63 (0.025 x 0.005) If fitted type 296	14.0 Miniwrap Contact	0.25µM Gold All Over (Standard)	60 8017 0633 00 339
 * Tail Section – 0.635 x 0.63 (0.025 x 0.005) If fitted type 504	4.3mm PC Solder Contact for ø 1.00 mm P.T.H.	0.25µM Gold All Over (Standard)	60 8017 0663 00 339

* Indicates standard contact

** Order code to be used when purchasing through a USA source.

CONNECTOR POLARIZATION

Varicon® 8016 Series connectors are designed with an integral polarizing system to ensure in high density environments that the correct halves are mated together.

As a factory standard, male plugs are set to the code P-G-1-G-1, with the female receptacles being set to the opposite matching code R-S-1-S-1.

Customers who need to use this facility can either configure the polarization codes themselves, or for an additional charge provide AVX with the required polarization codes for presetting by the factory.

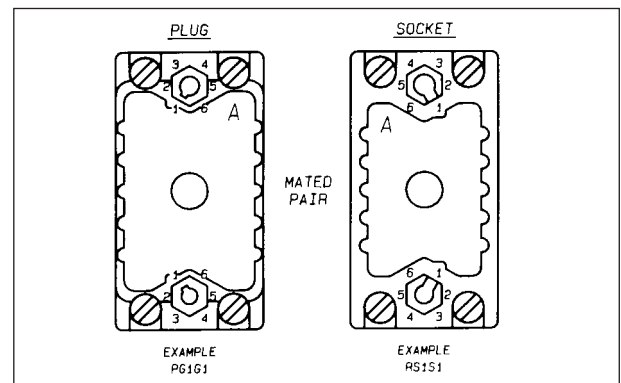

ORDERING CODE

P
Type of Connector Half
Plug = P
Socket = R

G
Location Side
(Large Dia.)
Guide Pin = G
Guide Socket = S

1
Positions
1 through 6

G
Location Side
(Small Dia.)
Guide Pin = G
Guide Socket = S

1
Positions
1 through 6

Tools

CONTACT INSERTION TOOLS

These are small hand tools which provide a positive method for inserting contacts into the rear of the insulator by applying pressure on the contacts directly to the end of the insulation crimp.

Tool	Contact Capability
06 1742 0400 00 000	Varilok®
	No. 60 8017 Family
06 7698 01 000 0000	Mini Varilok®
	No. 60 8216 Family



HAND CRIMP TOOL

This tool is designed for hand crimping of contacts. The tool is well suited for maintenance, model shop, laboratory and small scale production purposes. Two crimping cavities are available; Upper Cavity will crimp wire 18-20 AWG and the Lower Cavity will crimp wire 22-26 AWG.

Part No.	Contact Capability	Wire Type & Size
06 7852 0100 00 000	Varilok®	Stranded AWG
	No. 60 8017 0313	No. 18-26
	Mini Varilok®	Stranded AWG
06 7858 01 000 0000	No. 60 8216 0313	No. 22-30

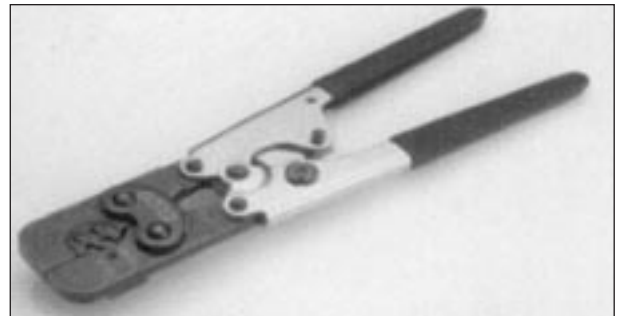

CONTACT EXTRACTION TOOLS

This tool is designed to extract contacts from the front of the insulator quickly and easily, without damage to either contacts or insulator.

Tool	Contact Capability
06 1877 0400 00 000	Varilok®
	No. 60 8017 Family
06 7699 01 000 0000	Mini Varilok®
	No. 60 8216 Family

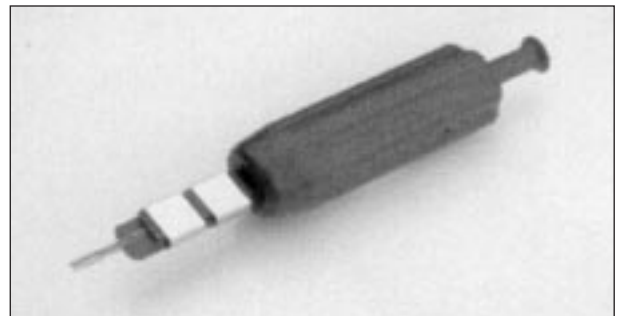

CRIMPING MACHINES

These heavy duty crimping machines are designed for fast and economical production-line crimping of contacts supplied on reels. The machines incorporate the unique DIALMATIC crimp adjustment which permits the machine operator to crimp contacts to wires of different sizes by simply adjusting two knobs.

SPECIFICATIONS

Press Rating: 3 Ton Capacity

Power: 240V AC, 50 Cycles

Part No.	Contact	Wire Size
HR-1 06 1984 0102	Varilok®	AWG No. 18-26

Series 8026 – 0.100" Rectangular Connector

FEATURES

- Economical miniature high-density connectors suitable for high-reliability and military applications.
- 0.100" (2.54mm) square grid rack and panel connectors with male and female insulators are available in four sizes: 33, 75, 117 and 165 contacts.
- Insertable / removable mini-varilok and mini-wrap contacts.
- Crimp and/or solderless wrap terminations.
- Exceptional versatility: all hardware can be mounted on plug or receptacle (see ordering code).
- Actuating screw facilitates mating and unmating; locks mated connectors together.
- Keyed and shrouded insulator design prevents incorrect mating and protects contacts from mishandling.
- Simplified polarizing hardware permits 36 polarization combinations per connector pair.
- Optional covers with top or side cable entry and clamp.
- Optional cable clamps.
- Choice of any combination of hardware — or no hardware.
- U.L. recognized-diallyl phthalate material.
- QPL approved-diallyl phthalate material.



TECHNICAL SPECIFICATIONS CONTACTS

Current Rating:
5 amperes

Contact Resistance:
6 milliohms

Withdrawal Force:
2 to 8 ounces max. per contact

Material:
Phosphor Bronze

Standard Plating:
Gold, 10 microinches min.,
over Nickel,
50-100 microinches

Spacing:
0.100" (2.54mm)

INSULATORS

Insulation Resistance:
5,000 megohms, min.
(diallyl phthalate insulators)
5,000 megohms, min.
(polycarbonate insulators)

Dielectric Withstanding Voltage:
Sea Level: 1,000 Volts rms
Materials:
0.100" (2.54mm) spacing –
diallyl phthalate, glass-filled,
flame resistant

ORDERING CODE

00

8026

033

Number of Contacts
033 = 33
075 = 75
117 = 117
165 = 165

000

Contact Code

Order crimp contacts separately by Part Number. Otherwise specify contact code 491.
000 = Crimp (3000 - contact reel)



Part Number
60 8216 0323 00 339

000 = Crimp (loose contact)
Accepts #22-30 AWG wire



Part Number
60 8216 0313 00 339

491 = Wire wrappable removable contact .025" (.635mm) sq. x .564" (14.33mm) tail



Part Number
60 8216 0413 00 339

803

Variation Code

Add 050 to order alternative keying (Pin & Socket)
i.e. 701 = Standard hermaphroditic keying
751 = Pin and socket keying
Complete a 15 digit assembly number for each mating part, male and female.

Series 8026 – 0.100" Rectangular Connector

VARIATION CODES

33 Contacts
Table 1

Insulator Body Type	Variation Code No.	Actuating Screw	Fixed Nut	Keying Hardware	Cover
Male (Exposed Contacts)	701	Yes	No	Yes	No
	702	Yes	No	No	No
	703	No	Yes	Yes	No
	704	No	Yes	No	No
	733	No	No	Yes	No
	734	No	No	No	No
Female (Recessed Contacts)	801	No	Yes	Yes	No
	802	No	Yes	No	No
	803	Yes	No	Yes	No
	804	Yes	No	No	No
	833	No	No	Yes	No
	834	No	No	No	No

33 Contacts
Table 2

Insulator Body Type	Variation Code No.	Actuating Nut	Fixed Nut	Keying Hardware	Cover
Male (Exposed Contacts)	501	Yes	No	Yes	No
	502	Yes	No	No	No
	503	No	Yes	Yes	No
	504	No	Yes	No	No
	601	No	Yes	Yes	No
Female (Recessed Contacts)	602	No	Yes	No	No
	603	Yes	No	Yes	No
	604	Yes	No	No	No

75, 117 & 165 Contacts
Table 3

Insulator Body Type	Variation Code No.			Cable Entrance	Actuating Screw	Fixed Nut	Keying Hardware	
	Without Cover	Cover Small Clamp	Cover Large Clamp					
Male (Exposed Contacts)	701	—	—	No	Yes	No	Yes	
	702	—	—	No	Yes	No	No	
	703	—	—	No	No	Yes	Yes	
	704	—	—	No	No	Yes	No	
	733	—	—	No	No	No	Yes	
	734	—	—	No	No	No	No	
	—	705	713	Top	Yes	No	Yes	
	—	706	714	Side	Yes	No	Yes	
	—	707	715	Top	Yes	No	No	
	—	708	716	Side	Yes	No	No	
	—	709	717	Top	No	Yes	Yes	
	—	710	718	Side	No	Yes	Yes	
	—	711	719	Top	No	Yes	No	
	—	712	720	Side	No	Yes	No	
	—	735	739	Top	No	No	Yes	
	—	736	740	Side	No	No	Yes	
	—	737	741	Top	No	No	No	
	—	738	742	Side	No	No	No	
	Female (Recessed Contacts)	801	—	—	No	No	Yes	Yes
		802	—	—	No	No	Yes	No
803		—	—	No	Yes	No	Yes	
804		—	—	No	Yes	No	No	
833		—	—	No	No	No	Yes	
834		—	—	No	No	No	No	
—		805	813	Top	No	Yes	Yes	
—		806	814	Side	No	Yes	Yes	
—		807	815	Top	No	Yes	No	
—		808	816	Side	No	Yes	No	
—		809	817	Top	Yes	No	Yes	
—		810	818	Side	Yes	No	Yes	
—		811	819	Top	Yes	No	No	
—		812	820	Side	Yes	No	No	
—		835	839	Top	No	No	Yes	
—		836	840	Side	No	No	Yes	
—		837	841	Top	No	No	No	
—		838	842	Side	No	No	No	

Table 4

Insulator Body Type	Variation Code No.			Cable Entrance	Actuating Nut	Fixed Screw	Keying Hardware
	Without Cover	Cover Small Clamp	Cover Large Clamp				
Male (Exposed Contacts)	501	—	—	No	Yes	No	Yes
	502	—	—	No	Yes	No	No
	503	—	—	No	No	Yes	Yes
	504	—	—	No	No	Yes	No
	—	505	513	Top	Yes	No	Yes
	—	506	514	Side	Yes	No	Yes
	—	507	515	Top	Yes	No	No
	—	508	516	Side	Yes	No	No
	—	509	517	Top	No	Yes	Yes
	—	510	518	Side	No	Yes	Yes
	—	511	519	Top	No	Yes	No
	—	512	520	Side	No	Yes	No
Female (Recessed Contacts)	601	—	—	No	No	Yes	Yes
	602	—	—	No	No	Yes	No
	603	—	—	No	Yes	No	Yes
	604	—	—	No	Yes	No	No
	—	605	613	Top	No	Yes	Yes
	—	606	614	Side	No	Yes	Yes
	—	607	615	Top	No	Yes	No
	—	608	616	Side	No	Yes	No
	—	609	617	Top	Yes	No	Yes
	—	610	618	Side	Yes	No	Yes
	—	611	619	Top	Yes	No	No
	—	612	620	Side	Yes	No	No

Series 8026 – 0.100" Rectangular Connector

33 CONTACTS

Female Plug (Recessed Contacts)
For variation code number

See Table 1
Page 25

See Table 2
Page 25

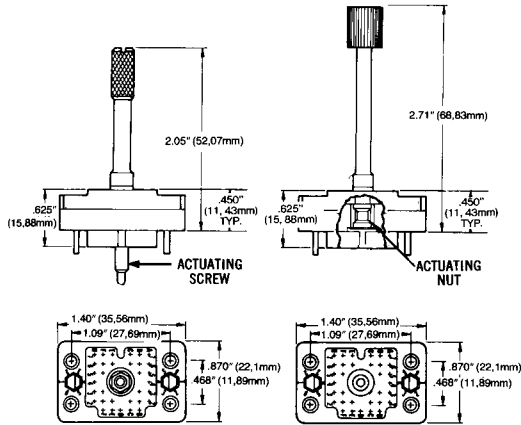

MALE RECEPTACLE (Exposed Contacts)

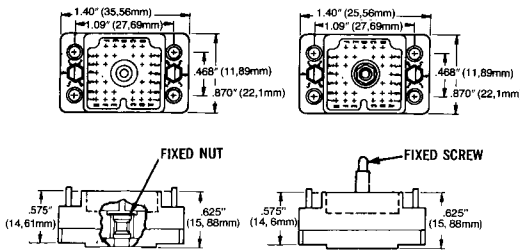

RECOMMENDED CHASSIS LAYOUT

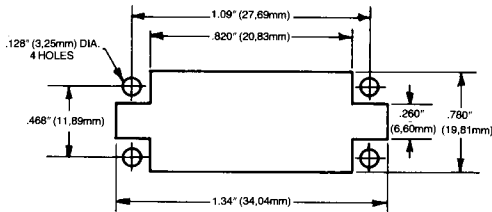

75 CONTACTS

Female Plug (Recessed Contacts)
For variation code number

See Table 3
Page 25

See Table 4
Page 25

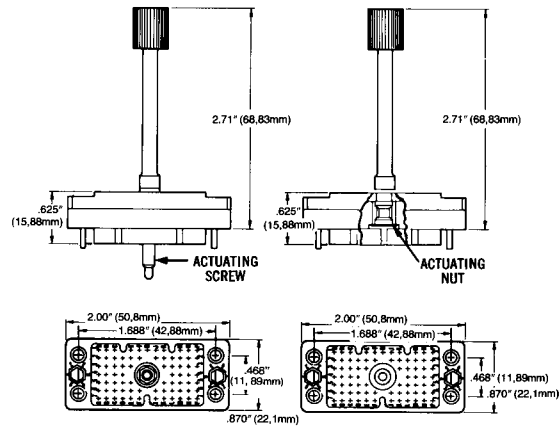

MALE RECEPTACLE (Exposed Contacts)

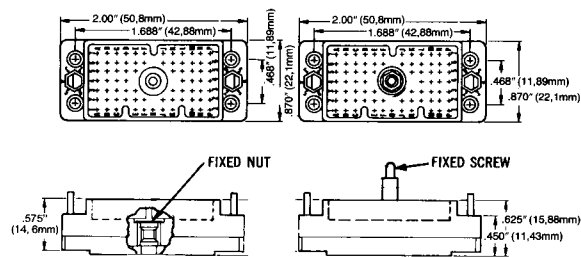

RECOMMENDED CHASSIS LAYOUT

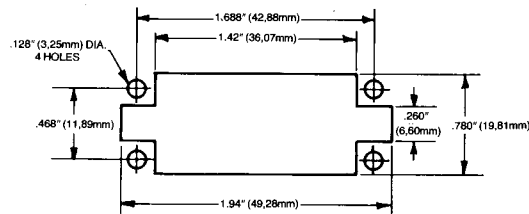

COVER CROSS REFERENCE, FOR DETAILS SEE 8016 CONNECTOR

Cover Number	Cable Entrance	Clamp	
		Description	8026/.100" (2.54mm) sq.
30-8016-9821	Side	Small	75 Pin
30-8016-9822	Top	Small	75 Pin
30-8016-9823	Side	Small	117 Pin
30-8016-9824	Top	Small	117 Pin
30-8016-9825	Side	Large	75 Pin
30-8016-9826	Top	Large	75 Pin
30-8016-9827	Side	Large	117 Pin
30-8016-9828	Top	Large	117 Pin
30-8016-9832	Side	Large	165 Pin

Cover Number	Cable Entrance	Clamp	
		Description	8026/.100" (2.54mm) sq.
30-8016-9833	Top	Large	165 Pin
30-8016-9838	Side	Ex-Large	75 Pin
30-8016-9839	Top	Ex-Large	75 Pin
30-8016-9840	Side	Ex-Large	117 Pin
30-8016-9842	Top	Ex-Large	117 Pin
30-8016-9843	Side	Ex-Large	165 Pin
30-8016-9844	Top	Ex-Large	165 Pin
30-8016-9845	Side	Ex-Large	—
30-8016-9846	Top	Ex-Large	—

Series 8026 – 0.100" Rectangular Connector

117 CONTACTS Female Plug (Recessed Contacts)

For variation code number

See Table 3
Page 25

See Table 4
Page 25

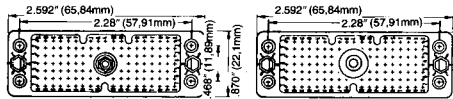
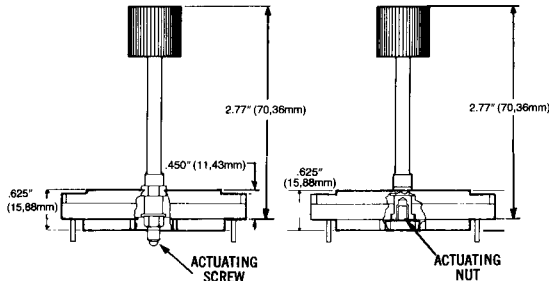

MALE RECEPTACLE (Exposed Contacts)

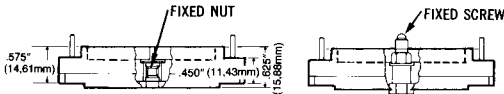
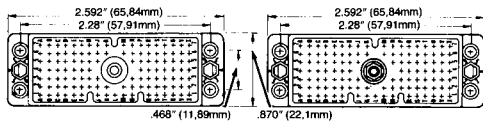

RECOMMENDED CHASSIS LAYOUT

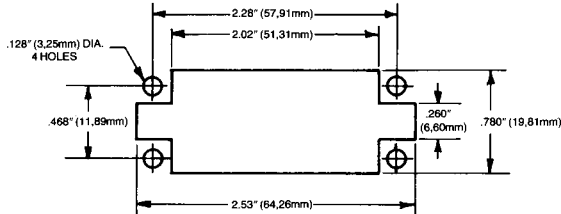

165 CONTACTS Female Plug (Recessed Contacts)

For variation code number

See Table 3
Page 25

See Table 4
Page 25

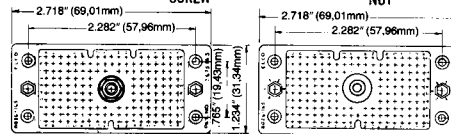
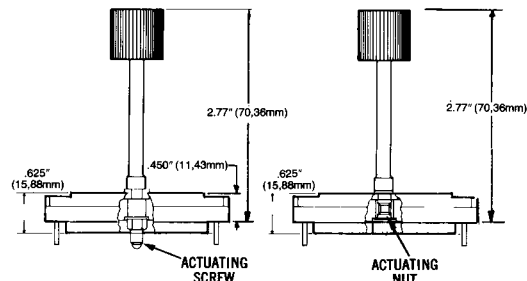

MALE RECEPTACLE (Exposed Contacts)

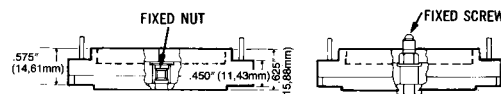
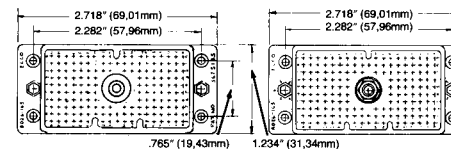

RECOMMENDED CHASSIS LAYOUT

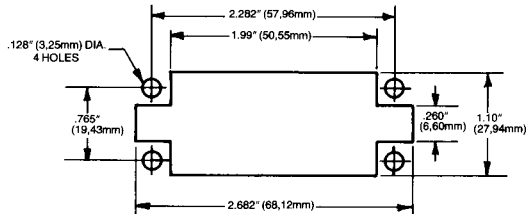

POLARIZATION CODE

Polarizing pins, when desired, are factory set in position #1. Customer can reset as shown below, use tool No. 06 1989 02. To order factory settings other than position #1, fill out

the "Polarization Code" below and submit it along with the completed connector ordering code.

P

Insulator Body Type
P = Male, R = Female

LS

Left Side Pin

5

Left Side Pin Position
1 through 6

RS

Right Side Pin

3

Right Side Pin Position
1 through 6

POLARIZATION / KEYING

EXAMPLE: P-LS-5-RS-3 Mates with R-LS-5-RS-3 as shown below

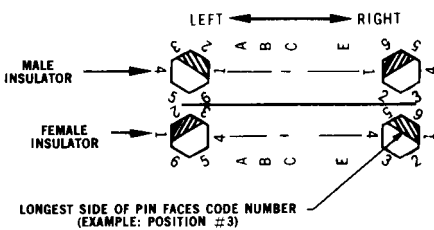

ALTERNATIVE KEYING

EXAMPLE (PIN & SOCKET)

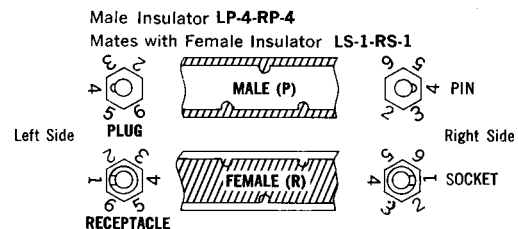

NOTE: Same size of pin and socket keying hardware are used on all existing 8026 connectors (33, 75, 117, 165) – both sides

Series 8223 – 0.100" Dual Row Square Grid

FEATURES

- Wide range of contact terminations including wire wrapping, P.C. solder tail, wire hole, wire crimp
- For 1/16", 3/32" P.C. card
- Polarity and keying are built into the connector body to prevent mismatching
- Perpendicular or parallel connector mounting
- Proven Varicon® contact reliability
- Protected male; recessed female contacts
- Conforms to MIL-C-55302 QPL



TECHNICAL SPECIFICATIONS CONTACTS

Current Rating:
5 amperes with 22 AWG wire

Contact Resistance:
6 milliohms, maximum

Contact Material and Plating:
Phosphor Bronze
Nickel plate, 50 to 100 micro-inches, followed by gold plate.
10 microinches minimum

INSULATORS

Material:
Diallyl Phthalate, glass-filled, flame resistant, per MIL-M-14-F, Type SDGF

Insulation Resistance:
5,000 megohms, minimum

Dielectric Withstanding Voltage:
Sea Level: 1,000 Volts rms

Insertion/Withdrawal Force:
2 to 8 ounces per contact

ORDERING CODE

00

8223

024

000

001

Number of Contacts
024, 048, 072 & 096

Contact Code

Variation Code

Use three digit code number when contacts are to be factory installed. If contacts are to be supplied loose, or contact tails to be formed, use three zeros (000) in contact code section. Note that the wire crimp tail contacts can only be ordered as separate items by part numbers.

Code	Profile	Description	Part No.	H Dim.	Board Thk.	Fig.
000		Coined Tail Formed 90° after installing (Max. 0236 Diag.)	60 8223 0223 60 8223 0213		.080 .062	1
000		Coined Tail Formed 90° after installing (Max. 0236 Diag.)	60 8223 0243 60 8223 0253		.093	1
473		P.C. Tail Coined (Max. 0236 Diag.)	60 8223 0233	.400		2
519		P.C. Tail Coined (Max. 0236 Diag.)	60 8223 0213	.279		2
520		P.C. Tail Coined (Max. 0236 Diag.)	60 8223 0223	.479		2
558		P.C. Tail Coined (Max. 0236 Diag.)	60 8223 0243	.309		2
559		P.C. Tail Coined (Max. 0236 Diag.)	60 8223 0253	.509		2
560		P.C. Tail Coined (Max. 0236 Diag.)	60 8223 0263	.341		2
561		P.C. Tail Coined (Max. 0236 Diag.)	60 8223 0273	.541		2
722		Wire Hole Tail (.032 x .050)	60 8200 1613	.162		3
721		P.C. Tail .020 Sq.	60 8200 1623	.228		4
736		P.C. Tail .020 Sq.	60 8200 1633	.259		4
737		P.C. Tail .020 Sq.	60 8200 1643	.541		4
753		P.C. Tail .020 Sq.	60 8200 1653	.103		4
771		P.C. Tail .020 Sq.	60 8200 1663	.462		4
000		Crimp Contact (Reel 3000) 22-30 AWG	60 8216 0323			5
000		Crimp Contact (Loose) 22-30 AWG	60 8216 0313			5
491		Wrappable/Removable Contact (.025 Sq.)	60 8216 0413	.560		6

Insulator Type	Variation	Contact Style	Accessories					Refer To Figure	Board Thickness	
			Cover	Bracket	Guide Pins Sockets (R)					
					Keying	Threaded Locking	Lkg. Kyg.			
Male (Exposed Contacts)	001	Formed Contact Terminal				X			1	.080 2.03 .062 1.57
	002	PC Terminal				X			2	
		Wire Hole Terminal				X			3	
		PC Straight Terminal				X			4	
	003	Crimp Contact				X			5	
		Wrappable Removable				X			6	
	004	Formed Contact Terminal				X			1	.093 2.36
	006						X		7	
	007	Similar to 001						X	8	
	008						X		7	
	009	Similar to 002						X	8	
	016						X		7	
	017	Similar to 004						X	8	
018						X		7		
019	Similar to 006						X	8		
Female (Exposed Contacts)	901	Formed Contact Terminal				X			1	.080 2.03 .062 1.57
	902	PC Terminal				X			2	
		Wire Hole Terminal				X			3	
		PC Straight Terminal				X			4	
	903	Crimp Contact				X			5	
		Wrappable Removable				X			6	
	904	Formed Contact Terminal				X			1	.093 2.36
	906						X		15	
	907	Similar to 901						X	16	
	908						X		15	
	909							X	16	
	916						X		15	
	917	Similar to 904						X	16	
	918						X		15	
	919	Similar to 905						X	16	

Series 8223 – 0.100" Dual Row Square Grid

MALE INSULATORS

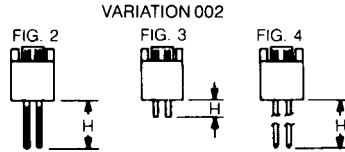
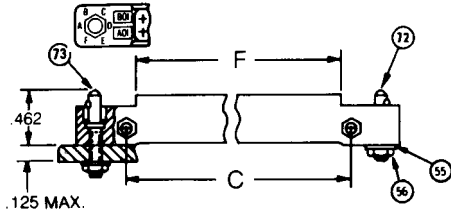
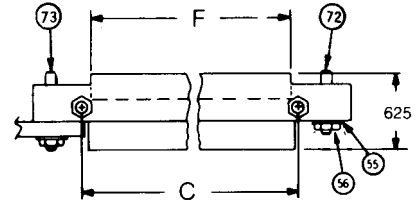
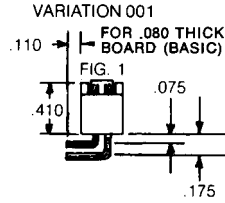
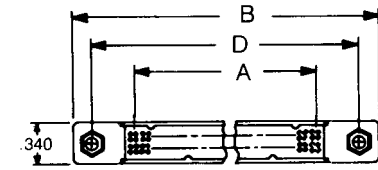

CRIMP TYPE

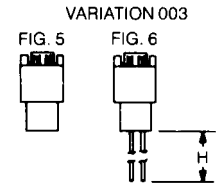

FEMALE INSULATORS

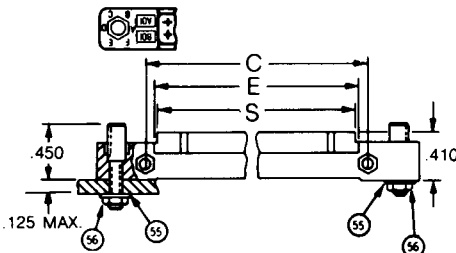

VARIATION 901
FIG. 1

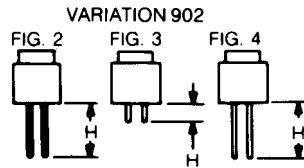
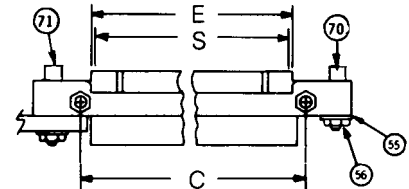
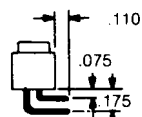

CRIMP TYPE

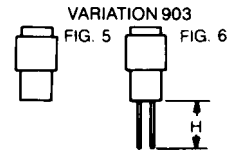

MOUNTING LAYOUT

Panel for Figures 2, 3, & 4

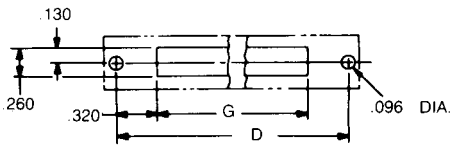

P.C. Board for Figure 1

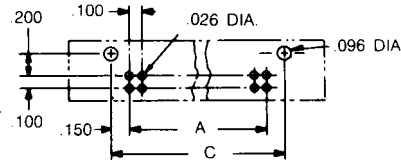

Panel for Figures 5 & 6

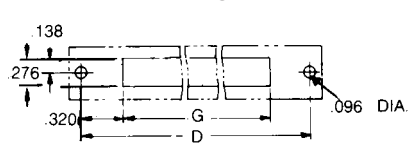

P.C. Board for Figures 2, 3, & 4

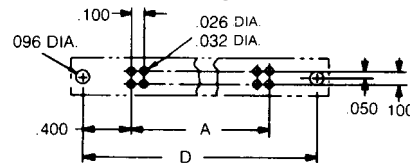

MOUNTING HARDWARE

(See drawings for correct assembly of hardware. Hardware shown is supplied with each connector.)

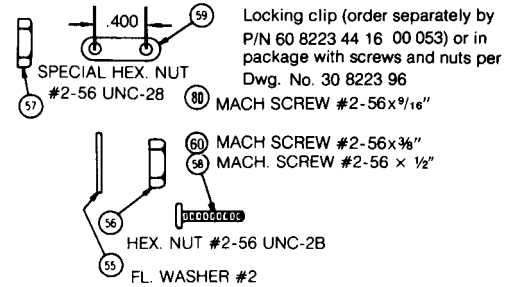

KEY TO DIAGRAMS

No. of Contacts	A	B	C	D	E	F	G	H	S
24	1.1	2.2	1.4	1.9	1.27	1.252	1.26	Pg. 24	1.236
48	2.3	3.4	2.6	3.1	2.47	2.452	2.46	Pg. 24	2.436
72	3.5	4.6	3.8	4.3	3.67	3.652	3.66	Pg. 24	3.636
96	4.7	5.8	5.0	5.5	4.87	4.852	4.86	Pg. 24	4.836

Item	Size	Part # Unified Thread
55	#2	90-0502-0031-11-053
56	#2-5	90-0602-0121-11-053
57	#2-5	90-2137-0185-11-053
58	#2-5	90-0902-0136-11-053
59		60-8223-4416-00-053

Item	Size	Part #
60	#2-5	90-0902-0096-11-053
70	#2-5	60-8223-4562-11-062
71	#2-5	60-8223-4522-11-062
72	#2-5	60-8223-4662-11-062
73	#2-5	60-8223-4662-11-062
80	#2-5	90-0902-0156-11-053

Series 8020 – Cable Connector

APPLICATION

In line connection of 2 or 3 wire of 18-26 AWG, insulation \varnothing 1.03 mm to 1.88 mm.

FEATURES AND BENEFITS

- 2 and 3 position in single row
- Uses identical molding for plug and socket
- Uses identical contact for plug and socket
- Uses standard Varicon 8016 contacts
- Uses standard Varicon Crimping Tools, Contact Extraction Tools and Insertion Tools
- Has combined nylon mounting and locking clip common to both sizes
- Contacts for both solder and crimp termination

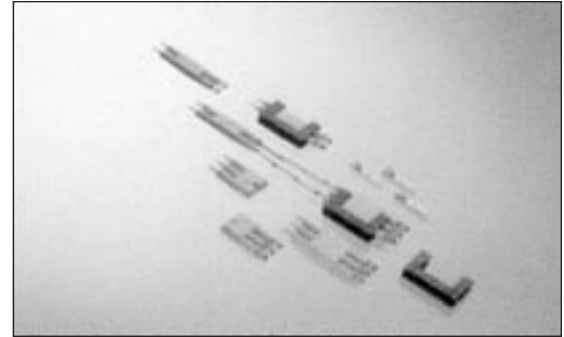

TECHNICAL SPECIFICATIONS

Contact:

Single row of 2 or 3 Varilok contacts

Contact Rating:

8.5 amperes

Insulation Resistance:

5,000 megohms (min)

Configuration:

On a 0.200 inch pitch, 5.08 mm

Contact Resistance:

6 milliohms (max)

Voltage Proof:

2,500 volts R.M.S. Sea Level

CONNECTOR DIMENSIONS (mm)

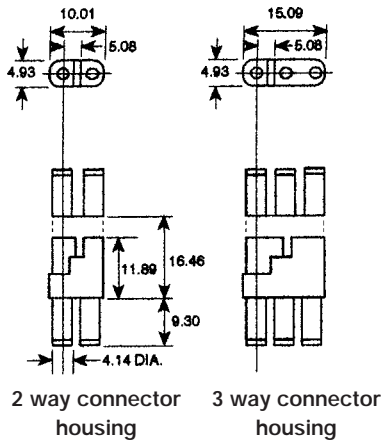

LOCKING CLIP DIMENSIONS (mm)

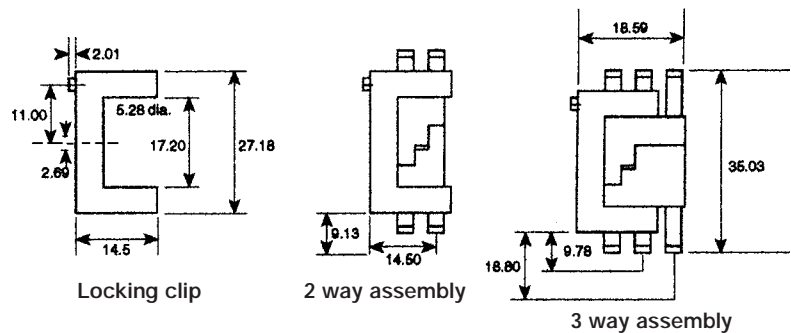

ORDERING CODE

FOR COMPLETE CONNECTORS WITH NON-CRIMP CONTACTS FITTED

00	8020	002	217	001
Prefix	Series Number	Number of Contacts 002 = Two way 003 = Three way	*Contact Termination 217 = Solder Tag 218 = Wire Wrap (0.61 x 1.27 x 14.4mm) 296 = Mini Wire Wrap (0.61 x 0.66 x 4.73mm) 504 = Solder Tail (0.61 x 0.66 x 4.32mm)	Variation Code

*Contact terminations should be insulated because they may protrude from the insulator.

NB: See page 22 for details of contacts.

ORDERING CODE FOR HOUSINGS AND CRIMP CONTACTS

Description	Part Number	Description	Part Number
2 way connector: Housing only	60-8020-3117-00-000	0.25 μ M Gold reeled crimp contacts (gold all over)	60-8017-0323-99-339
3 way connector: Housing only	60-8020-3317-00-000	0.25 μ M Gold reeled crimp contacts (selective)	60-8017-0323-99-042
0.25 μ M Gold loose crimp contacts (gold all over)	60-8017-0313-00-339	NB: See page 22 for details of crimp contacts	
0.25 μ M Gold loose crimp contacts (selective)	60-8017-0313-00-042	Locking clip	60-8020-3210-00-000

Series 8022 – Cable Connector

APPLICATION

In line connection of 3 wires of 18-26 AWG, insulation \varnothing 1.03 mm to 1.88 mm.

FEATURES

- 3 position in single row
- Male insulator incorporates two positive locking arms for up to 1.6 mm thick panel mount
- Uses identical contact for plug and socket
- Uses standard Varicon 8016 contacts (8017 Series)
- Uses standard Varicon Crimping Tools, Contact Extraction Tools and Insertion Tools
- Has mounting and locking clip mechanism
- Contacts for both solder and crimp termination

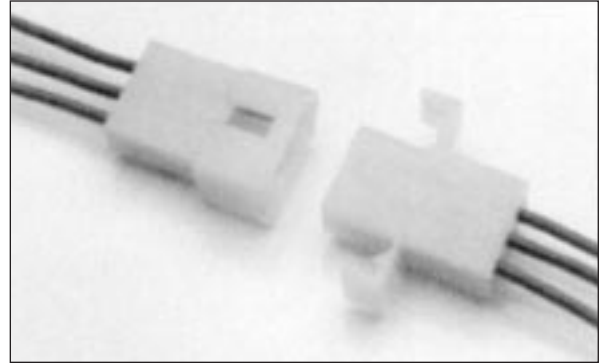

TECHNICAL SPECIFICATIONS

Contact Spacing:
5.08 mm

Contact Rating:
8.5 amperes

Contact Resistance:
6 milliohms (max)

Insulation Resistance:
5K megohms

Voltage Proof:
2.5K volts R.M.S. Sea Level

Operating Temperature:
-55°C to 125°C

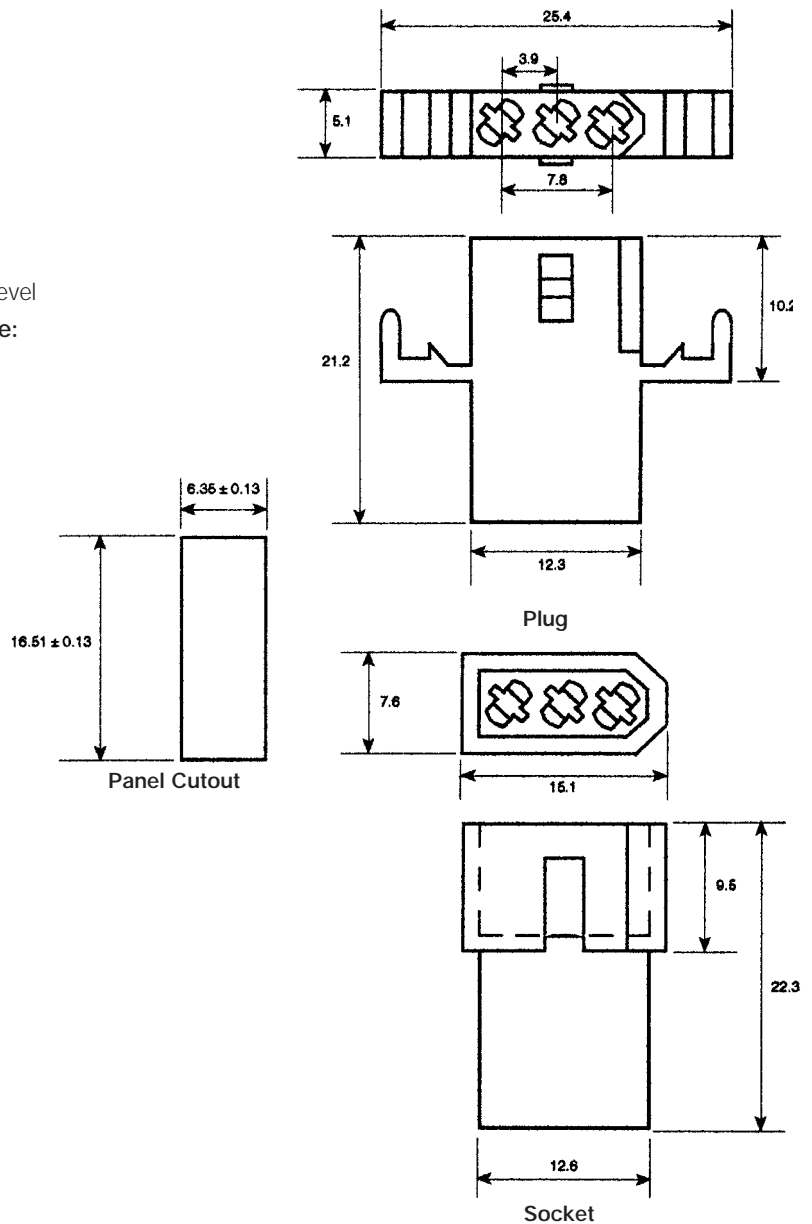

PART NUMBERS

Plug Molding: 60 8022 3218 00 000

Socket Molding: 60 8022 3318 00 000

Crimp Contacts (loose): 60 8017 0313 00 339

Crimp Contacts (reel): 60 8017 0323 00 339

Series 8218 – 0.050" Staggered Dual Row

FEATURES

- High contact density
- For parallel or perpendicular p.c. card mounting
- High mounting density (.050" centers, minimum)
- Nylon end sections for mounting and card guidance
- Mounting hardware supplied with connector
- Mates with 8219 Series



TECHNICAL SPECIFICATIONS

Current Rating:

5 amperes, maximum

Contact Resistance:

0.005 ohm, maximum

Contact Material and Plating:

Phosphor Bronze
nickel plate, 30 to 50 microinches followed by
gold plate, 10 to 20 microinches

Insulator Material:

Diallyl phthalate, glass-filled, flame resistant,
end guides: nylon

Insulation Resistance:

5,000 megohms, minimum

Dielectric Withstanding Voltage:

Sea Level: 1000 Volts rms
3.4" Hg: 500 Volts rms

Insertion/Withdrawal Force:

2 to 16 ounces per contact

ORDERING CODE

00

8218

100

000

004

Number of Contacts
002 to 076 for connectors
without center guide

Contact Code

Variation Code
001 = Receptacle
002 = Plug-Card
005 = Plug-Board

with keying pins

011 = Receptacle
012 = Plug-Card/pin
inserted in
odd position
013 = Plug-Card/pin
inserted in even
position
017 = Plug-Board

with keying holes

021 = Receptacle
022 = Plug-Card/pin
inserted in
odd position
023 = Plug-Card/pin
inserted in even
position
027 = Plug-Board

Variant 002 right angled contacts

000 = 60 8200 16 33
P.C. Tail



000 = 60 8200 16 63
P.C. Tail



Variants 001 and 005

722 = 60 8200 16 13
Wire Hole Tail



736 = 60 8200 16 33
P.C. Tail (X = 9/32", Y = 1/4")



753 = 60 8200 16 53
P.C. Tail (X = 1/8", Y = 3/32")



771 = 60 8200 16 63
P.C. Tail (X = 31/64", Y = 29/64")



Series 8218 – 0.050" Staggered Dual Row

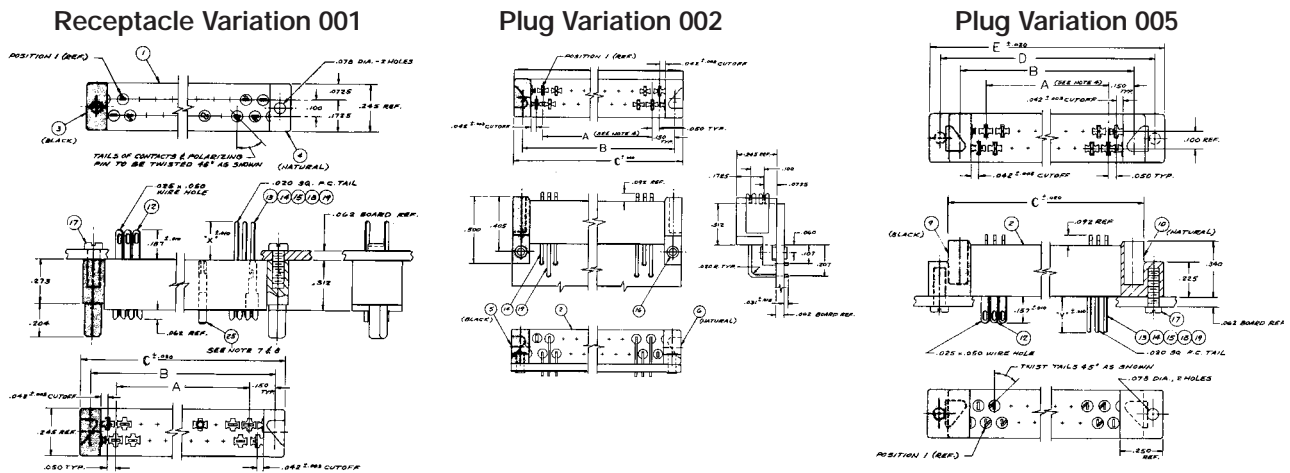

RECEPTACLE 001 – MATES WITH PLUGS 002 AND 005

MOUNTING LAYOUT

Variation 001 and 005

Variation 002

Minimum Center to Center Spacing for Adjustment Plugs

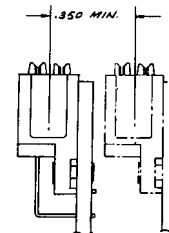
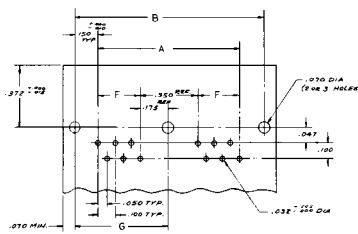
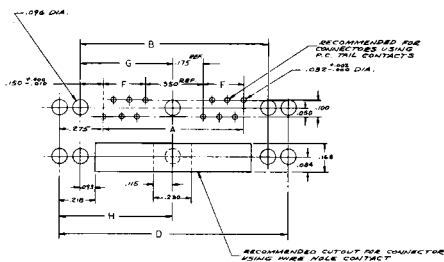

DIMENSIONS:

(inches)

A	B	C	D	E
(No. of contacts x 0.050") - 0.050"	"A" dimension + 0.300"	"A" dimension + 0.440"	"A" dimension + 0.550"	"A" dimension + 0.690"

POLARIZATION

Keying Ordering No.
60-8218-4715-00-148

PLUG OR RECEPTACLE



Determine polarization pin location from views.

P = Specify location by contact # where polarizing pin must be inserted.

H = Specify location by contact # where contact must be omitted for mating.

Typical Example: 00-8218-024-721-001-P-17 (polarizing pin mtd. in position 17)
00-8218-024-721-005-H-17 (polarizing hole is in position 17)

Series 8219 – 0.050" Staggered Dual Row

FEATURES

- For p.c. card-to-card applications
- High contact density
- Low withdrawal force contacts
- Rugged, color coded end guides
- Parallel or perpendicular p.c. board mounting
- Mates with Series 8218

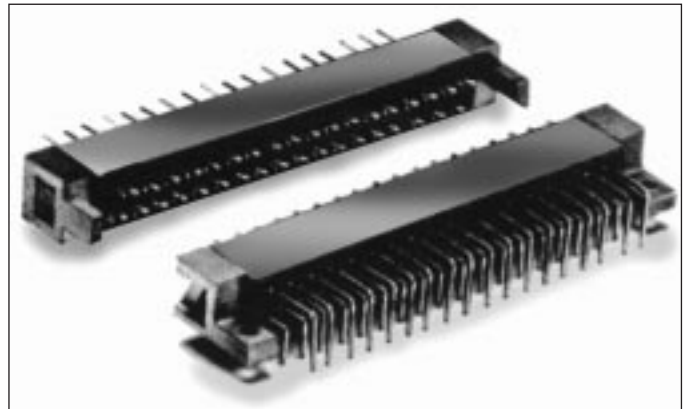

TECHNICAL SPECIFICATIONS

Current Rating:

5 amperes, maximum

Contact Resistance:

6 milliohms, maximum

Contact Material and Plating:

Phosphor Bronze

Gold, 10 microinches minimum, over nickel, 50 to 100 microinches

Insulator Material:

Diallyl phthalate, glass-filled, flame resistant per MIL-M-14F, Type SDGF.

Guidance Hardware:

Left hand guides: Metal, gold color
Right hand guides: Metal, silver color

Insulation Resistance:

5,000 megohms, minimum

Dielectric Withstanding Voltage:

Sea Level: 1000 Volts rms
3.4" Hg: 500 Volts rms

Insertion/Withdrawal Force:

2 to 8 ounces per contact

Conforms to Military Specifications:

MIL-C-55302 QPL Approved

ORDERING CODE

00

8219

042

722

001

Number of Contacts
018, 030, 036, 042, 054, 072

Contact Code
(see below)

Variation Code

For Variation = 001			For Variation = 002																						
Code No.	Contact Type	"X" Dim.	Code No.	Contact Type																					
722	Wire hole tail	.187	000	P. C. solder tails formed																					
721	P. C. solder tail	.250	722	Wire hole tail unformed																					
736	P. C. solder tail	.281	For Variation = 005 <table border="1"> <thead> <tr> <th>Code No.</th> <th>Contact Type</th> <th>"Y" Dim.</th> </tr> </thead> <tbody> <tr> <td>722</td> <td>Wire hole tail</td> <td>.157</td> </tr> <tr> <td>721</td> <td>P. C. solder tail</td> <td>.219</td> </tr> <tr> <td>736</td> <td>P. C. solder tail</td> <td>.250</td> </tr> <tr> <td>737</td> <td>P. C. solder tail</td> <td>.531</td> </tr> <tr> <td>753</td> <td>P. C. solder tail</td> <td>.093</td> </tr> <tr> <td>771</td> <td>P. C. solder tail</td> <td>.453</td> </tr> </tbody> </table>		Code No.	Contact Type	"Y" Dim.	722	Wire hole tail	.157	721	P. C. solder tail	.219	736	P. C. solder tail	.250	737	P. C. solder tail	.531	753	P. C. solder tail	.093	771	P. C. solder tail	.453
Code No.	Contact Type	"Y" Dim.																							
722	Wire hole tail	.157																							
721	P. C. solder tail	.219																							
736	P. C. solder tail	.250																							
737	P. C. solder tail	.531																							
753	P. C. solder tail	.093																							
771	P. C. solder tail	.453																							
737	P. C. solder tail	.562																							
753	P. C. solder tail	.125																							
771	P. C. solder tail	.484																							

Without Keying	
	001 = Receptacle
	002 = Plug, perpendicular board mounting
	005 = Plug, parallel board mounting

NOTE: Connector is supplied with mounting screws or eyelets, as applicable (see drawings).

Contact Factory for Special Variations.

POLARIZING SYSTEM

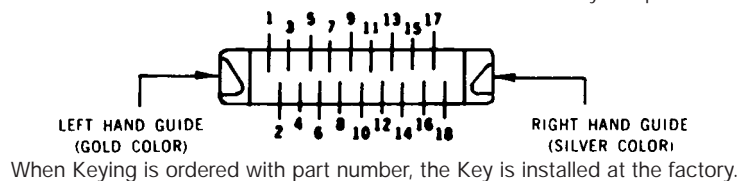

Series 8219 – 0.050" Staggered Dual Row

RECEPTACLE - VARIATION 001

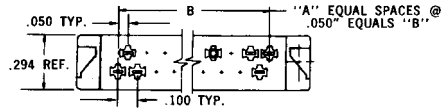
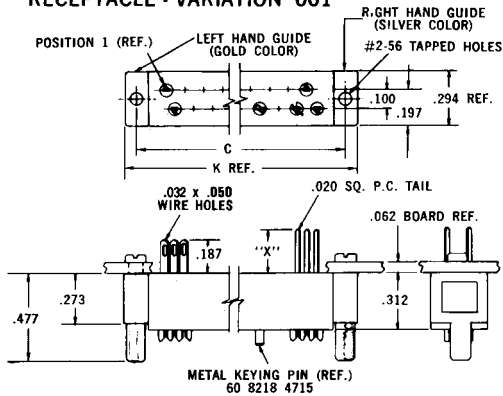

DIMENSIONS:

millimeters (inches)

Number of Contacts	A	B	C	Ref. D	E	F	G	Ref. K
18	17	.850 (0.033)	1.150 (0.045)	1.290 (0.051)	1.400 (0.055)	1.540 (0.061)	.964 (0.038)	1.300 (0.051)
30	29	1.450 (0.057)	1.750 (0.069)	1.890 (0.075)	2.000 (0.079)	2.140 (0.084)	1.564 (0.061)	1.900 (0.075)
36	35	1.750 (0.069)	2.050 (0.080)	2.190 (0.086)	2.300 (0.091)	2.440 (0.096)	1.864 (0.073)	2.220 (0.087)
42	41	2.050 (0.080)	2.350 (0.093)	2.490 (0.098)	2.600 (0.102)	2.740 (0.108)	2.164 (0.085)	2.500 (0.098)
54	53	2.650 (0.104)	2.950 (0.116)	3.090 (0.122)	3.200 (0.126)	3.340 (0.131)	2.764 (0.109)	3.100 (0.122)
72	71	3.550 (0.140)	3.850 (0.152)	3.990 (0.157)	4.100 (0.161)	4.240 (0.167)	3.664 (0.144)	4.000 (0.157)

RECEPTACLE 001 MATES WITH PLUGS 002 AND 005

PLUG - VARIATION 002

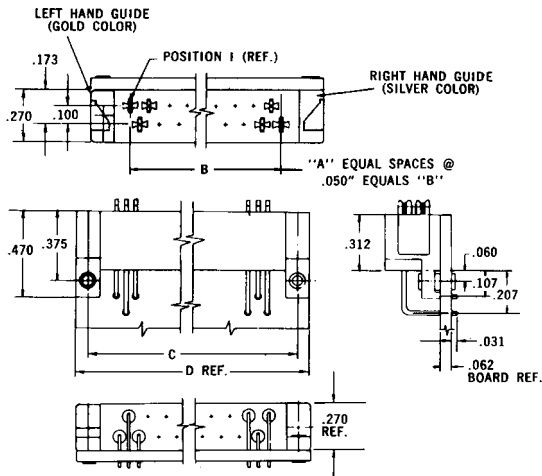

PLUG - VARIATION 005

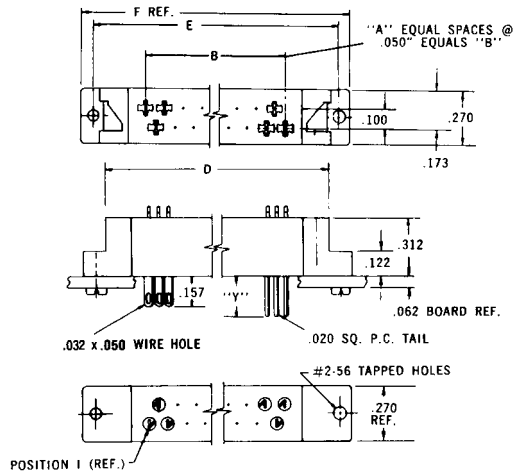

MOUNTING LAYOUTS

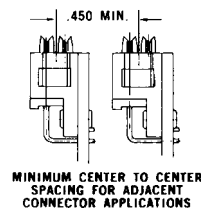
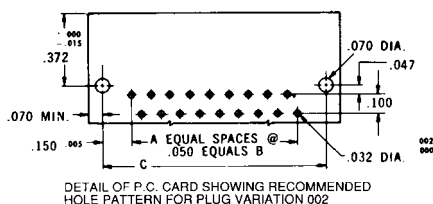
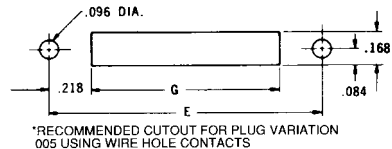
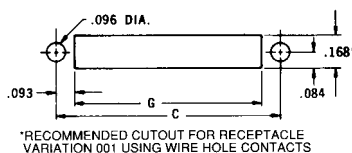
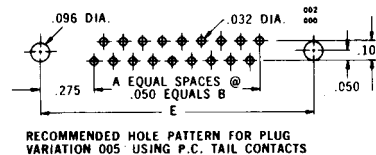
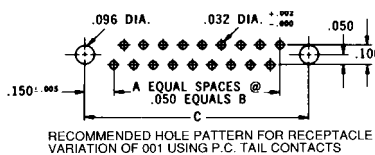

*When used in metal panel with Code Contact 722 cut out diam. Is .210".

Series 7008 – 0.100" Staggered Dual Row

FEATURES

- Available with or without card guides
- Many sizes
- Wide range of contact terminations
- For 1/8" thick PCB
- Polarization insert
- Mates with Series 7000 and 7022 Plugs



TECHNICAL SPECIFICATIONS

Current Rating:
10 amperes

Contact Resistance:
6 milliohms, maximum

Contact Material and Plating:
Phosphor Bronze per QQ-B-750, Composition A.

Gold, 10 microinches minimum, over nickel, 30 to 100 microinches

Insulator Material:
Diallyl phthalate, glass-filled, flame resistant, per MIL-M-14F, Type SDGF.

Insulation Resistance:
25,000 megohms, minimum

Dielectric Withstanding Voltage:
Sea Level: 2000 Volts rms
3.4" Hg: 675 Volts rms

Insertion/Withdrawal Force:
2 to 16 ounces per contact

Conforms to Military Specifications:
MIL-E-5400, MIL-E-8189, MIL-T-21200
MIL-E-19600 (BuWeeps), Paragraph 3.5.5.

ORDERING CODE

00

7008

017

146

001

Number of Contacts
017, 023, 029, 035, 041

Contact Code
See table.

Variation Code

141 = 60 7001 06 33 P.C. Termination for 1/8" Card	
146 = 60 7001 13 13 .078" Base Taper Tab	
156 = 60 7001 18 13 Wire wrapping (.026 x .062 x .600")	
163 = 60 7001 19 13 .098" Base Taper Tab w/Wire Hole	
165 = 60 7001 20 13 Forked Tail Solder Termination for Bus Line Connection (.056 x .125" Slot)	
166 = 60 7001 20 23 Dual Solder Termination for 2 Wires or Bus Line (.056 x .125" Slot)	
189 = 60 7004 02 13 Conventional Solder Termination for 3 Wires	

Card Slot	Card Guides	Code
1/16"	Yes	001
	No	002

Connector Description	Availability				
	No. of Contacts				
	17	23	29	35	41
With Guides – for 1/16" Card	X	X	X	X	X
Without Guides – for 1/16" /Card	X	X	X	X	X

Series 7008 – 0.100" Staggered Dual Row

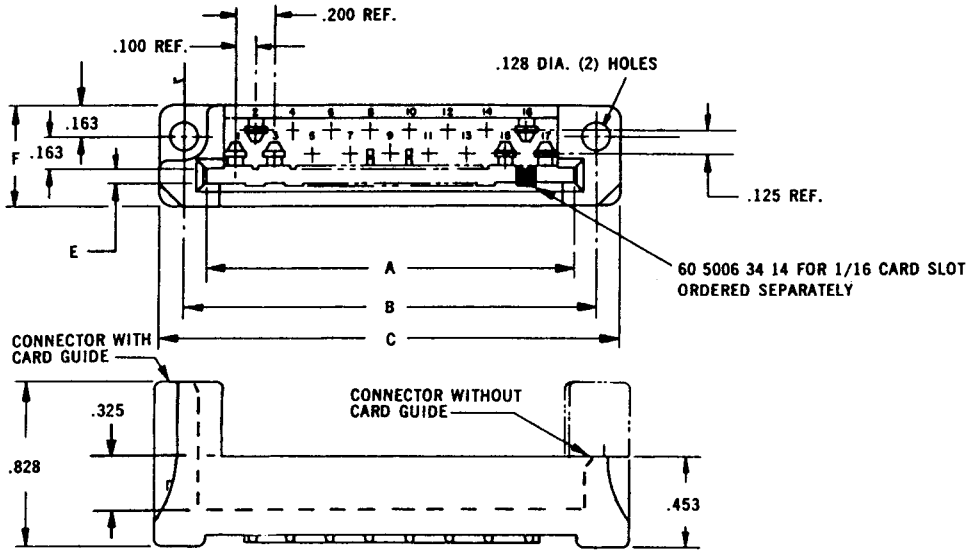

DIMENSIONS:

millimeters (inches)

Number of Contacts	A Bottom	B	C	D	E 1/16" Card	F	G*		H ±.003	L +.010 -.000	N*	
							Con.	N-Con.			Con.	N-Con.
17	1.920 (0.076)	2.134 (0.084)	2.40 (0.094)	1.835 (0.072)	.074 (0.003)	.531 (0.021)	.468 (0.018)	.343 (0.014)	1.600 (0.063)	1.900 (0.075)	.210 (0.008)	.148 (0.006)
23	2.520 (0.099)	2.734 (0.108)	3.00 (0.118)	2.435 (0.096)	.074 (0.003)	.531 (0.021)	.468 (0.018)	.343 (0.014)	2.200 (0.087)	2.500 (0.098)	.210 (0.008)	.148 (0.006)
29	3.120 (0.123)	3.334 (0.131)	3.60 (0.142)	3.035 (0.119)	.074 (0.003)	.531 (0.021)	.468 (0.018)	.343 (0.014)	2.800 (0.110)	3.100 (0.122)	.210 (0.008)	.148 (0.006)
35	3.270 (0.129)	3.934 (0.134)	4.20 (0.165)	3.635 (0.143)	.074 (0.003)	.531 (0.021)	.468 (0.018)	.343 (0.014)	3.400 (0.134)	3.700 (0.146)	.210 (0.008)	.148 (0.006)
41	4.320 (0.170)	4.534 (0.179)	4.80 (0.190)	4.235 (0.167)	.074 (0.003)	.531 (0.021)	.468 (0.018)	.343 (0.014)	4.000 (0.157)	4.300 (0.169)	.210 (0.008)	.148 (0.006)

*N-CON = Non-Conductive Chassis
(1/16" Clearance Around Contacts)

CON = Conductive Chassis
(1/8" Clearance Around Contacts)

P.C. CARD LAYOUT

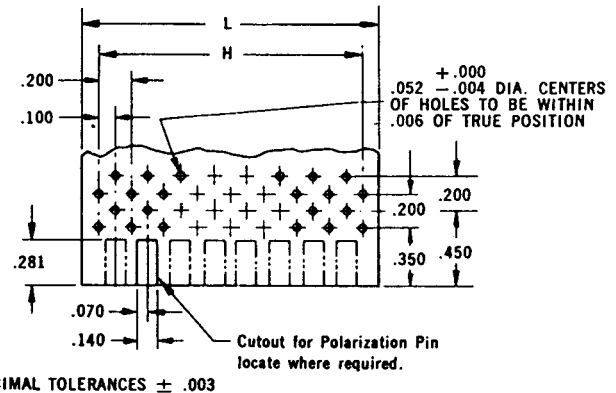
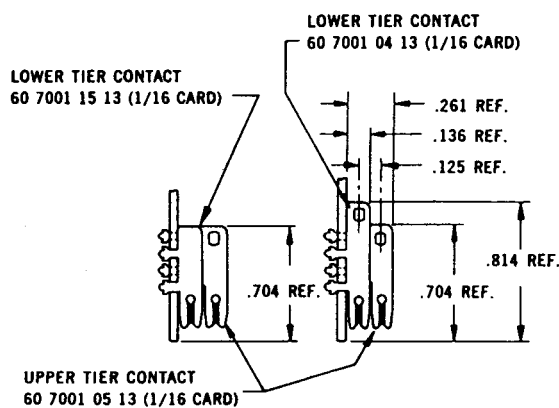

DECIMAL TOLERANCES ± .003

CHASSIS MOUNTING

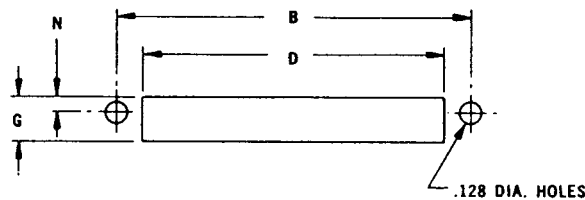

Series 7022 – 0.100" Staggered Dual Row

FEATURES

- Insulator rigidity reduces p.c. card warp
- Insulator maintains exact spacing between contacts
- Reduces cost of card punching operation (fewer holes)
- Reduces cost of contact staking operation (one operation instead of two)
- Reduces assembly time (no plastic strip to remove)
- For 1/16" or 3/32" p.c. card
- Mates with Series 7000 Receptacles with or without card guides

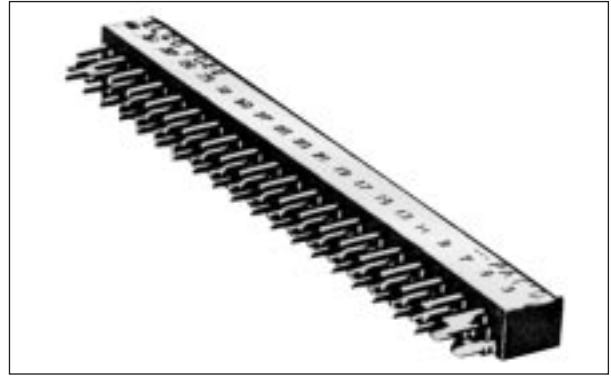

TECHNICAL SPECIFICATIONS

Current Rating:

10 amperes

Contact Resistance:

6 milliohms, maximum

Contact Material and Plating:

Phosphor Bronze per QQ-B-750, Composition A.

Gold, 10 microinches minimum, over nickel, 30 to 100 microinches

Insulator Material:

Diallyl phthalate, glass-filled, per MIL-M-14F, Type SDGF.

Variation 001/002

Thermoplastic Polycarbonate

Variation 003

Insulation Resistance:

25,000 megohms, minimum

Dielectric Withstanding Voltage:

Sea Level: 2000 Volts rms

3.4" Hg: 675 Volts rms

Insertion/Withdrawal Force:

2 to 16 ounces per contact

Conforms to Military Specifications:

MIL-E-5400, MIL-E-8189, MIL-T-21200
MIL-E-19600 (BuWeps), Paragraph 3.5.5.

ORDERING CODE

00

7022

023

Number of Contacts
017, 023, 029, 035, 041
For Series 7008 receptacle

000

001

Variation Code

001 = 1/16" Module Card Thickness
002 = 3/32" Module Card Thickness
003 = 1/16" Module Card Thickness

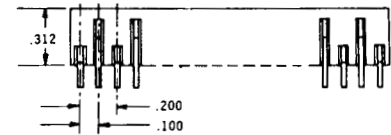
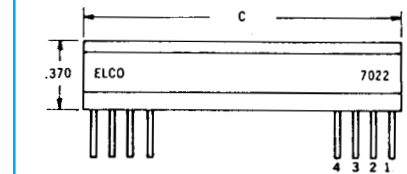

60 7001 2913 for 1/16" Card | 60 7001 2813 for 1/16" Card
60 7001 2923 for 3/32" Card | 60 7001 2823 for 3/32" Card

MOUNTING LAYOUT

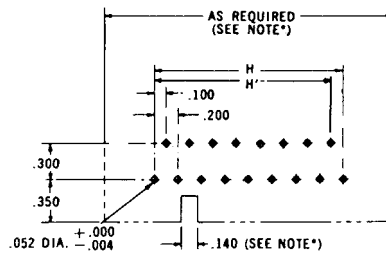

Series 7023 – 0.100" Staggered Dual Row

FEATURES

- Conforms to MIL-C-21097 Qualified Products List (QPL) - approved
- Guide pins facilitate mating, ensure correct alignment
- Insulator rigidity reduces p.c. card warp
- Insulator maintains exact spacing between contacts
- Reduces cost of card punching operation (fewer holes)
- Reduces cost of contact staking operation (one operation instead of two)
- Reduces assembly time (no plastic strip to remove)
- For 1/16" or 3/32" p.c. card
- Mates with Series 7024 and 7038 Receptacles

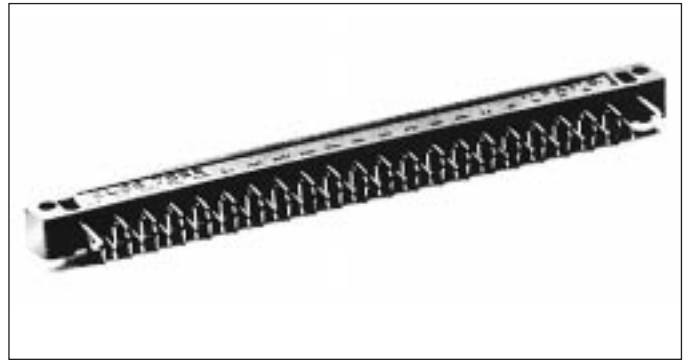

TECHNICAL SPECIFICATIONS

Current Rating:

10 amperes

Contact Resistance:

6 milliohms, maximum

Contact Material and Plating:

Phosphor Bronze per QQ-B-750, Composition A.

Gold, 10 microinches minimum, over nickel, 30 to 100 microinches

Insulator Material:

Diallyl phthalate, glass-filled, flame resistant per MIL-M-14F, Type SDGF.

Variation 001/002/110/111

Thermoplastic Polycarbonate

Variation 003

Insulation Resistance:

25,000 megohms, minimum

Dielectric Withstanding Voltage:

Sea Level: 1800 Volts rms

3.4" Hg: 675 Volts rms

Insertion/Withdrawal Force:

2 to 16 ounces per contact

Conforms to Military Specifications:

MIL-C-21097, MIL-E-5400, MIL-E-8189, MIL-T-21200, MIL-E-19600 (Para. 3.5.5), MIL-STD-454.

00



7023



023



000



001



Number of Contacts
017, 023, 029, 035, 041, 047

MOUNTING LAYOUT

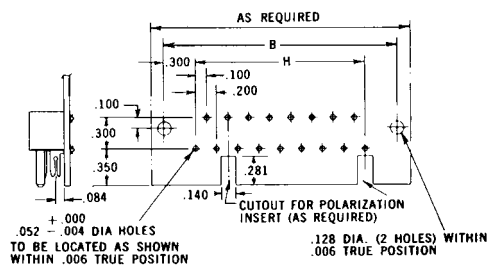

Diallyl Phthalate Glass Filled

1/16" Card	3/32" Card	1/16" Card
001	002	003
110*	111*	

*Conforms to MIL-C-21097

Contacts used in this connector:

Card	Upper Card Contacts	Lower Card Contacts
1/16"	60 7001 29 13	60 7001 28 13
3/32"	60 7001 29 23	60 7001 28 23

DIMENSIONS: millimeters (inches)

Number of Contacts	B	C Max.	H
17	2.200 (0.087)	2.470 (0.097)	1.600 (0.063)
23	2.800 (0.110)	3.070 (0.121)	2.200 (0.087)
29	3.400 (0.134)	3.670 (0.144)	2.800 (0.110)
35	4.000 (0.157)	4.270 (0.168)	3.400 (0.134)
41	4.600 (0.181)	4.870 (0.192)	4.000 (0.157)
47	5.200 (0.205)	5.470 (0.215)	4.600 (0.181)

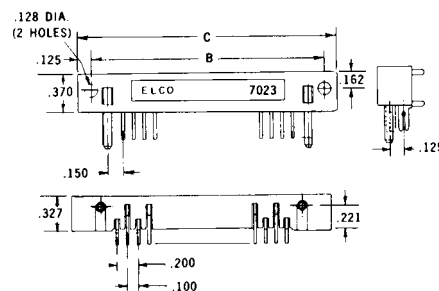

Series 7024 – 0.100" Staggered Dual Row

FEATURES

- Conforms to MIL-C-21097 Qualified Products List (QPL)
- Guide sockets facilitate mating, ensure correct alignment
- Open-ended card slot; use with p.c. card of any width
- Wide range of contact terminations
- Many sizes available
- For 1/16" or 3/32" p.c. card
- Mates with Series 7023 Plug

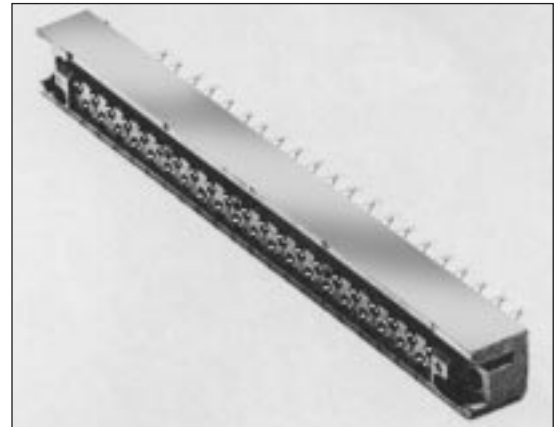

TECHNICAL SPECIFICATIONS

Current Rating:
10 amperes

Contact Resistance:
6 milliohms, maximum

Contact Material and Plating:
Phosphor Bronze per QQ-B-750, Composition A.

Gold, 10 microinches minimum, over nickel, 30 to 100 microinches

Insulator Material:
Diallyl phthalate, glass-filled, flame resistant, per MIL-M-14F, Type SDGF.

Insulation Resistance:
25,000 megohms, minimum

Dielectric Withstanding Voltage:
Sea Level: 1800 Volts rms
3.4" Hg: 675 Volts rms

Insertion/Withdrawal Force:
2 to 16 ounces per contact

Conforms to Military Specifications:
MIL-C-21097, MIL-E-5400, MIL-E-8189, MIL-T-21200, MIL-E-19600 (Para. 3.5.5), MIL-STD-454.

ORDERING CODE

00

7024

023

163

001

Number of Contacts
017, 023, 029, 035, 041

Contact Code
See table.

Variation Code
001 = 1/16" Thick Card
002 = 3/32" Thick Card
110* = 1/16" Thick Card
111* = 3/32" Thick Card

* For Conformance to MIL-C-21097B

141 = 60 7001 06 33 P.C. Termination for 1/8" Card	
146 = 60 7001 13 13 .078" Base Taper Tab	
156 = 60 7001 18 13 Wire wrapping (.026 x .062 x .600")	
163 = 60 7001 19 13 .098" Base Taper Tab w/Wire Hole	
165 = 60 7001 20 13 Forked Tail Solder Termination for Bus Line Connection (.056 x .125" Slot)	
166 = 60 7001 20 23 Dual Solder Termination for 2 Wires or Bus Line (.056 x .125" Slot)	
189 = 60 7004 02 13 Conventional Solder Termination for 3 Wires	

Connector Description	Availability				
	No. of Contacts				
	17	23	29	35	41
For 1/16" Card	X	X	X	X	X
For 3/32" Card	X	X	X	X	X

Series 7024 – 0.100" Staggered Dual Row

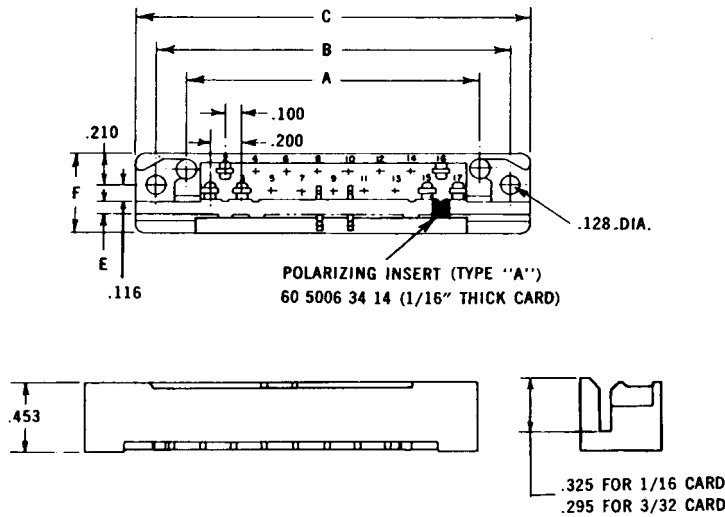

DIMENSIONS:

millimeters (inches)

Number of Contacts	A	B	C Max.	D	E $\pm .003$ / $\pm .002$		F	G††		H	N††	
					1/16" Card	3/32" Card		Con.	N-Con.		Con.	N-Con.
17	1.900 (0.075)	2.300 (0.091)	2.570 (0.101)	1.185 (0.072)	.074 (0.003)	.105 (0.004)	17/32"	.468 (0.018)	.343 (0.014)	1.600 (0.063)	.208 (0.008)	.146 (0.006)
23	2.500 (0.098)	2.900 (0.114)	3.170 (0.125)	2.435 (0.096)	.074 (0.003)	.105 (0.004)	17/32"	.468 (0.018)	.343 (0.014)	2.200 (0.087)	.208 (0.008)	.146 (0.006)
29	3.100 (0.122)	3.500 (0.138)	3.770 (0.148)	3.035 (0.119)	.074 (0.003)	.105 (0.004)	17/32"	.468 (0.018)	.343 (0.014)	2.800 (0.110)	.208 (0.008)	.146 (0.006)
35	3.700 (0.146)	4.100 (0.161)	4.370 (0.172)	3.635 (0.143)	.074 (0.003)	.105 (0.004)	17/32"	.468 (0.018)	.343 (0.014)	3.400 (0.134)	.208 (0.008)	.146 (0.006)
41	4.300 (0.169)	4.700 (0.185)	4.970 (0.196)	4.235 (0.167)	.074 (0.003)	.105 (0.004)	17/32"	.468 (0.018)	.343 (0.014)	4.000 (0.157)	.208 (0.008)	.146 (0.006)

†† N-CON = Non-Conductive Chassis
(1/16" Clearance Around Contacts)

CON = Conductive Chassis
(1/8" Clearance Around Contacts)

MOUNTING LAYOUT

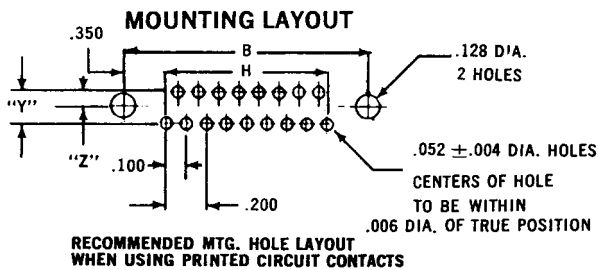

STANDARD CENTERS WHEN "Y" = .125; "Z" = .088

SPECIAL CENTERS WHEN "Y" = .150; "Z" = .100

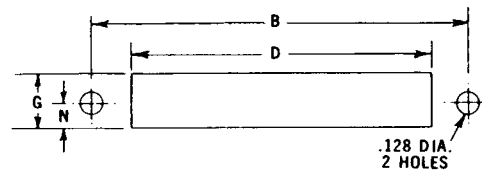

Varicon®

Series 7038 – 0.100"

Staggered Dual Row, Crimp Contacts



FEATURES

- Varilok® contacts are insertable and removable by user
- Crimp, solderless wrap, tapered tab, and wire hole terminations available
- All crimping, insertion, and extraction equipment available
- Guide sockets facilitate mating, ensure correct alignment
- Open-ended card slot; no p.c. card notching necessary
- Mates with Series 7023 Plug



TECHNICAL SPECIFICATIONS

Current Rating:

8 amperes

Contact Resistance:

6 milliohms, maximum

Contact Material and Plating:

Phosphor Bronze

Gold, 10 microinches minimum, over nickel, 50 to 100 microinches

Insulator Material:

Diallyl phthalate, glass-filled, flame resistant, per MIL-M-14F, Type SDGF.

Insulation Resistance:

5,000 megohms, minimum

Dielectric Withstanding Voltage:

Sea Level: 1800 Volts rms

3.4" Hg: 675 Volts rms

Insertion/Withdrawal Force:

2 to 16 ounces per contact

Conforms to Military Specifications:

MIL-E-5400, MIL-E-8189, MIL-T-21200.

ORDERING CODE

00

7038

023

000

001

Number of Contacts

017, 023, 029,
035, 041, 047

Contact Code

See table.

Variation Code

001 = 1/16" Thick Card
002 = 3/32" Thick Card
110* = 1/16" Thick Card
111* = 3/32" Thick Card

* For Conformance to MIL-C-21097

217 = 60 8017 05 13	
Wire Hole	
218 = 60 8017 06 13	
Solderless Wrap Tail - .025" x .050" x .567"	
750 = 60 8017 06 23	
Solderless Wrap Tail - .025" x .050" x .760"	
296 = 60 8017 06 33	
Solderless Wrap Tail - .025" x .025" x .580"	
504 = 60 8017 06 63	
Solderless Wrap Tail - .025" x .025" x .170"	
*000 = 60 8017 03 13	
Wire Crimp Tail (Contacts Loose) 18-26 AWG	
*000 = 60 8017 03 23	
Wire Crimp Tail (Contacts on a Reel) 18-26 AWG	

*Order separately by part number, refer to page 22

Varicon®

Series 7038 – 0.100"

Staggered Dual Row, Crimp Contacts

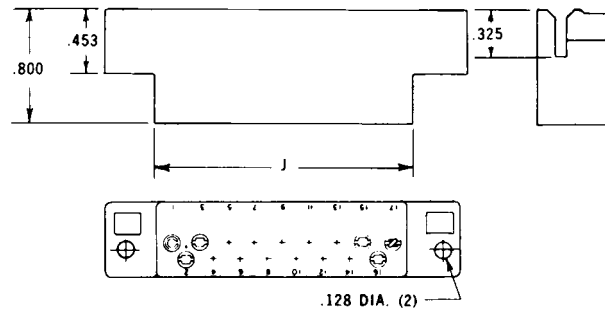
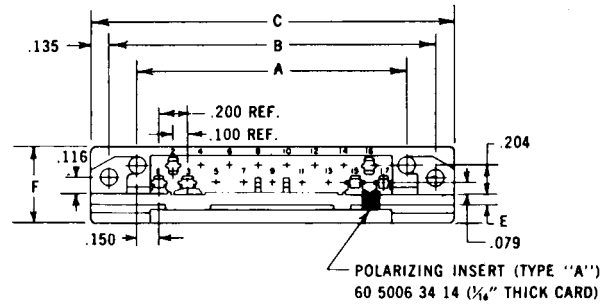

DIMENSIONS:

millimeters (inches)

Number of Contacts	A	B	C Max.	D	E		F	G	J
					1/16" Card	3/32" Card			
17	1.900 (0.075)	2.300 (0.091)	2.570 (0.101)	1.890 (0.075)	.074 (0.003)	.105 (0.004)	17/32"	.571 (0.022)	1.850 (0.073)
23	2.500 (0.099)	2.900 (0.114)	3.170 (0.125)	2.490 (0.098)	.074 (0.003)	.105 (0.004)	17/32"	.571 (0.022)	2.450 (0.096)
29	3.100 (0.122)	3.500 (0.138)	3.770 (0.148)	3.090 (0.121)	.074 (0.003)	.105 (0.004)	17/32"	.571 (0.022)	3.050 (0.120)
35	3.700 (0.146)	4.100 (0.161)	4.370 (0.172)	3.690 (0.145)	.074 (0.003)	.105 (0.004)	17/32"	.571 (0.022)	3.650 (0.144)
41	4.300 (0.169)	4.700 (0.185)	4.970 (0.196)	4.290 (0.169)	.074 (0.003)	.105 (0.004)	17/32"	.571 (0.022)	4.250 (0.167)
47	4.900 (0.193)	5.300 (0.209)	5.570 (0.219)	4.890 (0.193)	.074 (0.003)	.105 (0.004)	17/32"	.634 (0.025)	4.850 (0.191)

MOUNTING LAYOUT

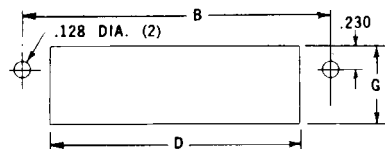

Series 7000 – Contact Strip

FEATURES

- Plug consists only of contacts staked and soldered to p.c. card; no other insulator needed
- For 1/16" thick p.c. cards
- Contacts supplied imbedded in vinyl strips, correctly spaced and ready for insertion and staking into p.c. card
- Mates with Series 7000 Receptacles

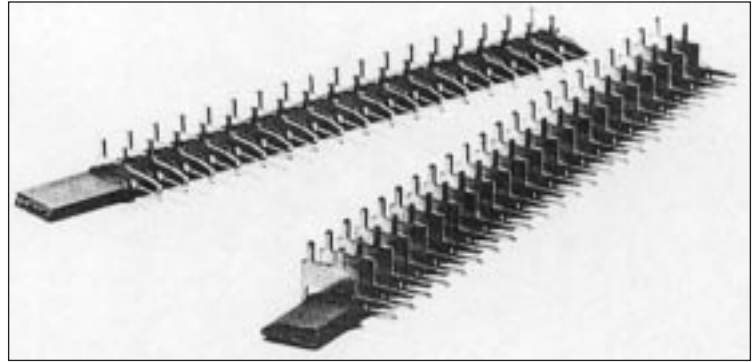

TECHNICAL SPECIFICATIONS

Current Rating:
10 amperes

Contact Resistance:
6 milliohms, maximum

†ELCO Standard Plating shown. Other plating may be supplied on request.

Contact Material and Plating:
Phosphor Bronze per QQ-B-750, Composition A.

†Gold, 10 microinches minimum, over nickel, 30 to 100 microinches

Insertion/Withdrawal Force:
2 to 16 ounces per contact

Conforms to Military Specifications:
MIL-E-5400, MIL-E-8189, MIL-T-21200
MIL-E-19600 (BuWeps), Paragraph 3.5.5.

ORDERING CODE

02

000

147

5

200

000

Number of Contacts
1 (001) to 60 (060)

Contact Code
See table.

Contact
Pattern

Contact
Pitch

Upper Tier and Lower Tier
Contacts on Separate Strips

Contact	Contact Code	Contact Part No.	Silhouette
1/16" Thick Card			
Lower Tier	147	60 7001 15 13	
Lower Tier with Wire Hole	135	60 7001 04 13	
Upper Tier with Wire Hole	137	60 7001 05 13	
Lower Tier with Wire Hole	144	60 7001 11 13	

For loose contacts, order by individual part numbers tabulated on page 51.

Varicon®

Series 5101 – Contact Strip

Tandem Cards – Pad Spacings .125"/.150"/.200"

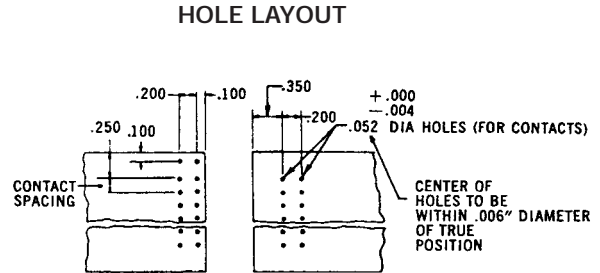
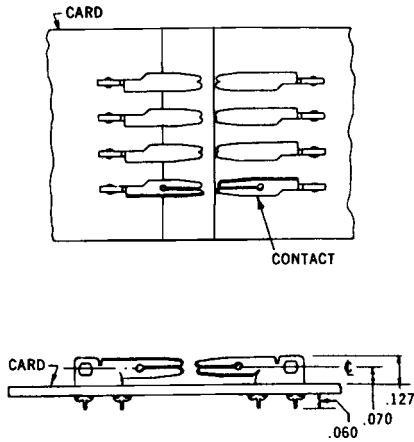

TECHNICAL SPECIFICATIONS

Contacts:

Contacts on .125", .150" or .200" Centers
 Contacts supplied on disposable plastic carrier strips.

Current Rating:

8 amperes

Contact Resistance:

0.006 Ohm, maximum

Contact Material and Plating:

Phosphor Bronze
 Gold, 10 microinches minimum,
 over nickel, 50 to 100 microinches

Insertion/Withdrawal Force:

2 to 16 ounces per contact

Conforms to Military Specifications:

MIL-E-5400, MIL-E-8189, MIL-T-21200

CONTACTS

Contacts are available on three spacings; each spacing has a corresponding maximum number of contacts. Fewer contacts can be ordered.

- .200" spacing with a max. of 60 contacts.
- .150" spacing with a max. of 80 contacts.
- .125" spacing with a max. of 90 contacts.

ORDERING CODE

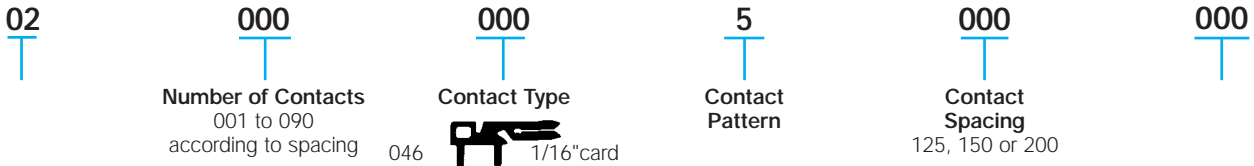

For loose contacts, order by individual part numbers tabulated on page 51.

Varicon®

Series 5203 – Contact Strip

Perpendicular Cards – Pad Spacing .100"



FEATURES

- For 1/16" and 3/32" thick p.c. cards
- Contacts supplied imbedded in vinyl strips, correctly spaced and ready for insertion and staking into p.c. card
- Complete set of plug contacts supplied on two disposable plastic strips, one for upper-tier contacts, the other for lower-tier contacts
- Efficient and economical installation equipment includes staking and strip removal tools for all applications

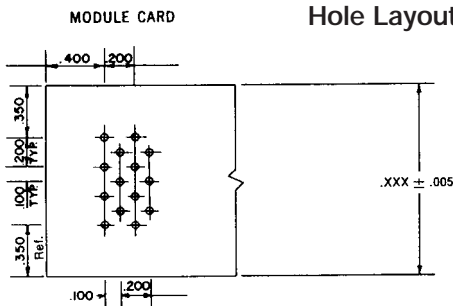

All hole diameters are .052 to .060
 Hole locations to be within .006" diameter of true location

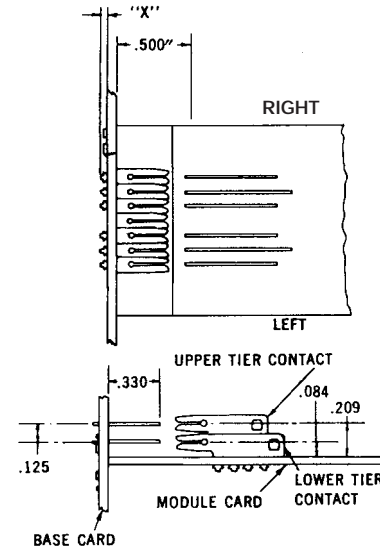
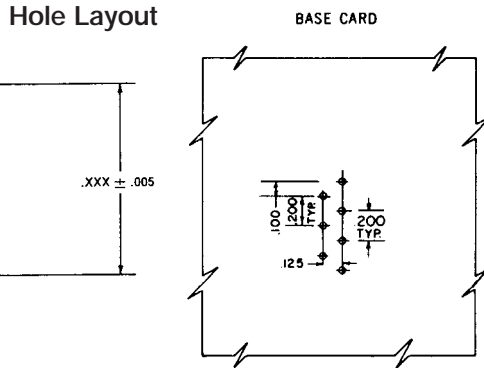

Contact	"X"
113	.060
114	.060
120	.313
121	.281
122	.250

TECHNICAL SPECIFICATIONS

Current Rating:
8 amperes

Contact Resistance:
0.006 Ohm, maximum

†ELCO Standard Plating shown. Other plating may be supplied on request.

Contact Material and Plating:
Phosphor Bronze

†Gold, 10 microinches minimum, over nickel, 50 to 100 microinches

Insertion/Withdrawal Force:
2 to 16 ounces per contact

Conforms to Military Specifications:
MIL-E-5400, MIL-E-8189, MIL-T-21200

ORDERING CODE – BASE CARD CONTACTS

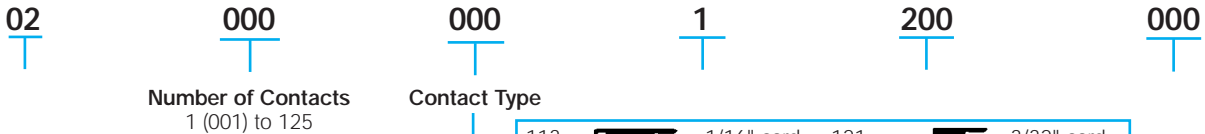

113		1/16" card	121		3/32" card
120		1/16" card	122		1/8" card
114		3/32" card			

ORDERING CODE – MODULE CARD CONTACTS

Upper-tier and Lower-Tier Contacts on Separate Strips

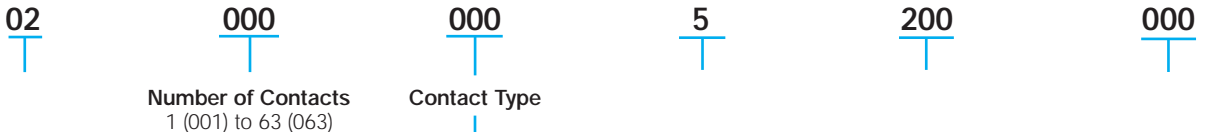

Lower Tier:		Upper Tier:	
135		137	
144			
147			
228			

Lower and upper tier contacts are ordered separately. Order one extra lower tier contact when pattern is to start and end with a lower tier contact (example – 9 lower tier and 8 upper tier).

For loose contacts, order by individual part numbers tabulated on page 51.

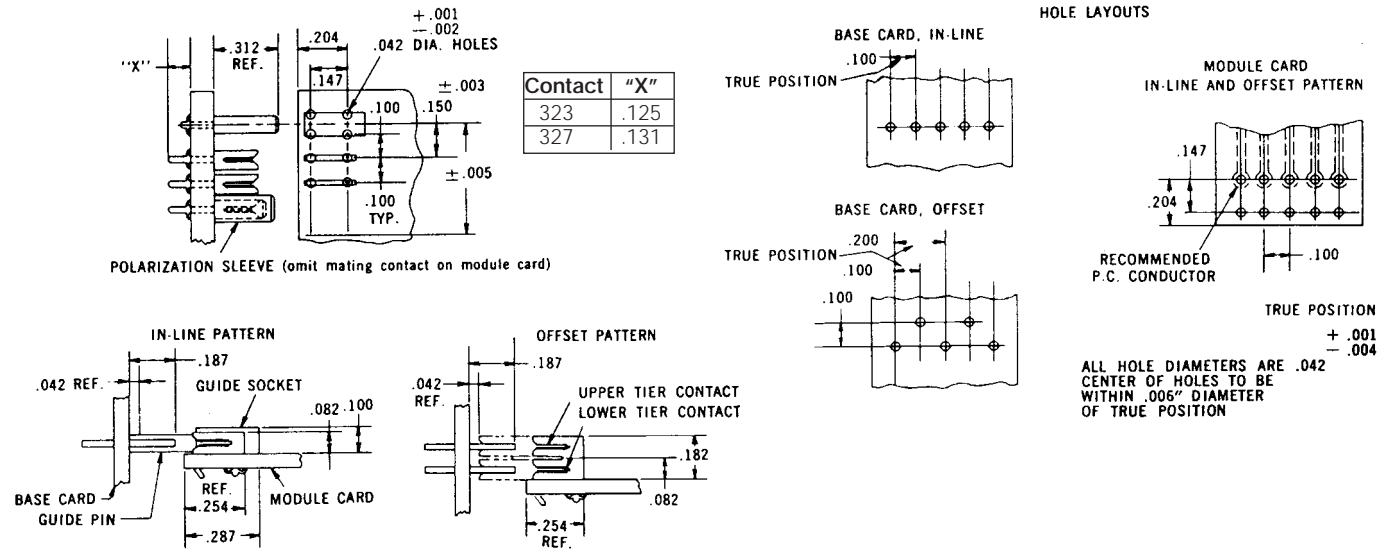

TECHNICAL SPECIFICATIONS

Contacts:

Supplied on disposable plastic carrier strips

Current Rating:

5 amperes

Contact Resistance:

0.006 Ohm, maximum

Contact Material and Plating:

Phosphor Bronze

†Gold, 10 microinches minimum, over nickel, 50 to 100 microinches

Insertion/Withdrawal Force:

2 to 16 ounces per contact

Conforms to Military Specifications:

MIL-E-5400, MIL-E-8189, MIL-T-21200

†ELCO Standard Plating shown. Other plating may be supplied on request.

ORDERING CODE – BASE CARD CONTACTS

02

000

000

30

000

000

Number of Contacts
1 to 123

Contact Type

Pattern
3 – for In-Line Pattern
9 – for Offset Pattern

Spacing Code
100 – for In-Line Pattern
200 – for Offset Pattern

Variation
000 – for In-Line Pattern
009 – for Offset Pattern
010 – for Offset Pattern

323		1/16" card
327		3/32" card

For loose contacts, order by individual part numbers tabulated on page 51.

ORDERING CODE – MODULE CARD CONTACTS

Upper-tier and Lower-Tier Contacts on Separate Strips

02

000

000

5

000

Number of Contacts
1 – 120 for In-Line Pattern
1 – 60 for Offset Pattern

Contact Types

In-Line:		
332		1/16" card
Offset:		
332		1/16" card, Lower Tier
372		1/16" card Upper Tier

Spacing Code
100 – for In-Line Pattern
200 – for Offset Pattern

Lower and upper tier contacts of the offset pattern assembly are ordered separately. Order one extra lower tier contact when pattern is to start and end with a lower tier contact (example – 9 lower tier and 8 upper tier).

For loose contacts, order by individual part numbers tabulated on page 51.

Varicon®

Series 5208 – Contact Strip

Perpendicular Cards – Pad Spacing .200"

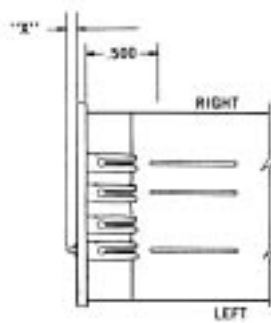

Contact	"X"
113	.060
114	.060
115	.060
120	.313
121	.281
122	.250

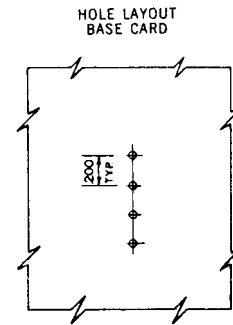
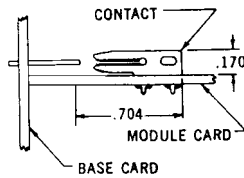
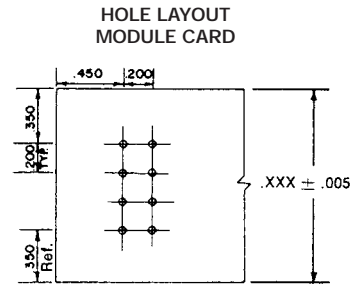

All hole diameters are $+.000$
 $-.004$
Hole locations to be within
.006" diameter of true location

TECHNICAL SPECIFICATIONS

Contacts:
Supplied on disposable plastic carrier strips.

Current Rating:
8 amperes

Contact Resistance:
0.006 Ohm, maximum

Contact Material and Plating:
Phosphor Bronze
Gold, 10 microinches minimum,
over nickel, 50 to 100 microinches

Insertion/Withdrawal Force:
2 to 16 ounces per contact

Conforms to Military Specifications:
MIL-E-5400, MIL-E-8189, MIL-T-21200

ORDERING CODE – BASE CARD CONTACTS

- Card Guides: See top drawing for appropriate part number
- Contacts

02

000

000

3

200

Number of Contacts
1 to 63

Contact Type

113		1/16" card
120		1/16" card
114		3/32" card
121		3/32" card
122		1/8" card

ORDERING CODE – MODULE CARD CONTACTS

02

000

000

5

200

Number of Contacts
1 to 63

Contact Type

In-Line:		
013		1/16" card
014		3/32" card

For loose contacts, order by individual part numbers tabulated on page 51.

Varicon®

Series 5301 – Contact Strip

Parallel Cards – .438" Between Cards

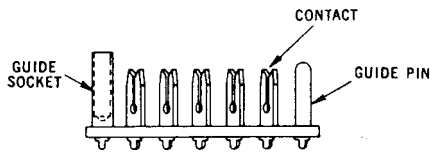

Contact	"X"
113	.060
114	.060
120	.313
121	.281
122	.250

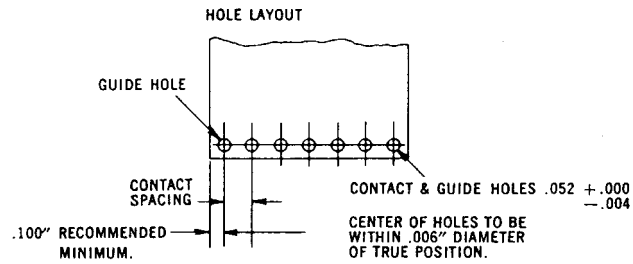
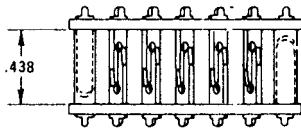
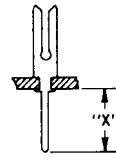

TECHNICAL SPECIFICATIONS

Contacts:

Supplied on disposable plastic carrier strips

Current Rating:

8 amperes

Contact Resistance:

0.006 Ohm, maximum

Contact Material and Plating:

Phosphor Bronze

Gold, 10 microinches minimum, over nickel, 50 to 100 microinches

Insertion/Withdrawal Force:

2 to 16 ounces per contact

Conforms to Military Specifications:

MIL-E-5400, MIL-E-8189, MIL-T-21200

ORDERING CODE

- Guide Pin – 62 5301 41 12 00 062 (1/16" card)
62 5301 41 22 00 062 (3/32" card)
- Guide Socket – 62 5301 40 12 00 062 (1/16" card)
62 5301 40 22 00 062 (3/32" card)

- Contacts – Contacts are available on four spacings; each spacing has a corresponding maximum number of contacts. Fewer contacts can be ordered.
.200" spacing with a max. of 60 contacts per strip
.150" spacing with a max. of 80 contacts per strip
.125" spacing with a max. of 90 contacts per strip

02

000

000

6

000

Number of Contacts
001 to 090
according to spacing

Contact Type

113		1/16" card
120		1/16" card
114		3/32" card
121		3/32" card
122		1/8" card

Contact Spacing
125, 150 or 200

For loose contacts, order by individual part numbers tabulated on page 51.

Varicon®

Series 5304 – Contact Strip

Parallel Cards – .213" Between Cards

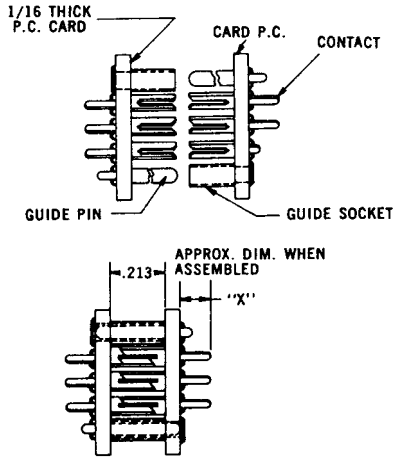

Contact	"X"
323	.125
327	.131

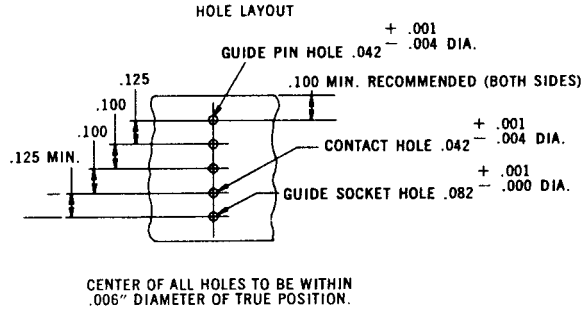

TECHNICAL SPECIFICATIONS

Contacts:

Contacts on .100 Centers
Supplied on disposable plastic carrier strips

Current Rating:

5 amperes

Contact Resistance:

0.006 Ohm, maximum

Contact Material and Plating:

Phosphor Bronze

Gold, 10 microinches minimum,
over nickel, 50 to 100 microinches

Insertion/Withdrawal Force:

2 to 16 ounces per contact

Conforms to Military Specifications:

MIL-E-5400, MIL-E-8189, MIL-T-21200

ORDERING CODE

- Guide Pin – 62 8202 40 12 00 062 (1/16" card)
- Guide Socket – 62 5304 40 12 00 062 (1/16" card)
62 5301 40 12 00 062 (3/32" card)

02

000

000

6

100

Number of Contacts
001 to 120

Contact Type

323		1/16" card
327		3/32" card

For loose contacts, order by individual part numbers tabulated on page 51.

Contacts can be fastened to the p.c. card by staking or soldering and by the combination of staking and soldering. Contact retention tests indicate that it requires 25 lbs. of force to pull out a soldered contact, 45 lbs. for a staked contact and 65 lbs. for a staked and soldered contact.

Staking is accomplished with a knife-like tool which shaves a portion of the contact leg against the p.c. card. Elco can furnish the necessary staking equipment for both high quantity production and laboratory experimentation.

Once the contacts are fastened to the board it is generally necessary to remove the plastic carrier strip. The plastic should be softened prior to removal to avoid the possibility of inadvertently bending the contacts.

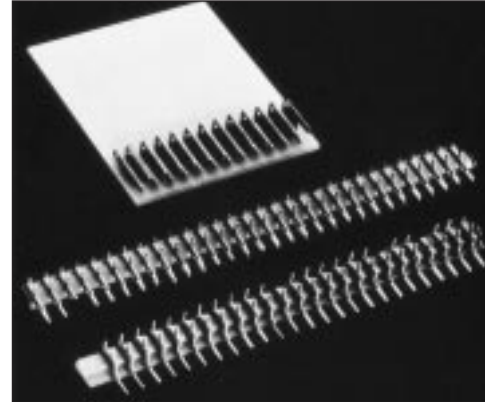

Contacts supplied embedded in disposable plastic strips, correctly spaced and ready for insertion and staking into p.c. card.

HAND STAKER MODEL NO. 06 1856 01

Hand staker 06 1856 01 is designed for use as a multi-purpose laboratory tool. This versatile tool enables you to stake most contacts presently available. The hand staker and replacement staking punches are available from stock.

SPECIFICATIONS

- Rating – 1/4 ton capacity
- Ram Dimensions – 1/2" x 1/2" x 2 1/2"
- Ram Stroke – 1 3/8"
- Height of Opening – under punch 1"
- Throat depth from center of ram – 1"
- Working Surface – 2" x 2 7/8"
- Weight – 3 lbs.
- Size – 4" wide x 5" deep x 4" high

ORDERING CODE FOR LOOSE CONTACTS

Contact Code Number	Loose Contact Part Number	Staking Punch Part Number
013	60 5001 19 13 00 339	66 1280 02
014	60 5001 19 23 00 339	66 1280 02
046	62 5101 06 43 00 339	66 1280 02
113	62 5201 02 13 00 339	66 1280 02
114	62 5201 02 23 00 339	66 1280 02
120	62 5201 05 13 00 339	66 1280 19
121	62 5201 05 23 00 339	66 1280 19
122	62 5201 05 33 00 339	66 1280 19
135	60 7001 04 13 00 339	66 1280 02
137	60 7001 05 13 00 339	66 1280 02
144	60 7001 11 13 00 339	66 1280 02
147	60 7001 15 13 00 339	66 1280 02
228	60 7001 15 93 00 339	66 1280 02
332	60 8240 03 13 00 339	66 1280 17
371	60 8240 26 13 00 339	66 1280 17
372	60 8240 26 23 00 339	66 1280 17
323	60 8240 02 13 00 339	66 1280 17
327	60 8240 02 43 00 339	66 1280 26



Laboratory Tool for Contact Staking Model 06 1856 01 (Staking Punch Not Included)

ORDERING CODE FOR CARD GUIDE STAKING EQUIPMENT

Card Guide Number
62 5204 41 12 00 062
62 5204 40 12 00 062
62 8202 40 12 00 062
62 8202 40 02 00 062
62 5304 40 12 00 062
62 5304 40 02 00 062
62 5301 41 12 00 062
62 5301 41 22 00 062
62 5301 41 32 00 062
62 5301 40 12 00 062
62 5301 40 22 00 062
62 5301 40 32 00 062

Need Additional Information on AVX Products

Internet –

For more information visit us on the worldwide web at <http://www.avxcorp.com>

FAX Back Service –

Just dial 1-800-879-1613 and request the index for additional catalog information faxed to your FAX number.

CD ROM –

Or get in touch with your AVX representative for a CD Rom or copies of the catalogs and technical papers.

Software –

Comprehensive capacitor application software library which includes:

- SpiCap (for MLC chip capacitors)
- SpiTan (for tantalum capacitors)
- SpiCalci (for power supply capacitors)
- SpiMic (for RF-Microwave capacitors)

AVX Products

PASSIVES

Capacitors

- Multilayer Ceramic
- Tantalum
- Microwave
- Glass
- Film
- Power Film
- Power Ceramic
- Ceramic Disc
- Trimmers

Resistors

- Chip
- Networks/Arrays
- Potentiometers

Timing Devices

- Resonators
- Oscillators
- Crystal

Filters

- EMI
- Bulk
- Saw
- Dielectric

Thin Film

- Inductors
- Fuses
- Capacitors

Integrated Passive Components

- Low Inductance Chip Arrays
- "Z" Chips
- Capacitor Arrays
- Dual Resonance Chips

Voltage Suppressor, Varistors and Thermistors

Acoustical Piezos

Ferrites

CONNECTORS

Automotive Connectors

Board to Board Connectors –
SMT and Through-Hole

Card Edge

Custom Designed Connectors

Customized Backpanel, Racking and
Harnessing Services

DIN 41612 Connectors

Insulation Displacement Connectors

I/O Connectors

Memory Card Headers and Sockets

MOBO™, I/O, Board to Board and
Battery Connectors

Press-fit Connectors

Torsion, 1.27mm (.050") Board to
Board Connectors

Wire to Board, Crimp or IDC

NOTICE: Specifications are subject to change without notice. Contact your nearest AVX Sales Office for the latest specifications. All statements, information and data given herein are believed to be accurate and reliable, but are presented without guarantee, warranty, or responsibility of any kind, expressed or implied. Statements or suggestions concerning possible use of our products are made without representation or warranty that any such use is free of patent infringement and are not recommendations to infringe any patent. The user should not assume that all safety measures are indicated or that other measures may not be required. Specifications are typical and may not apply to all applications.

Elco – World Class Connections

USA

AVX Myrtle Beach, SC Corporate Offices

Tel: 843-448-9411
FAX: 843-448-1943

AVX Northwest, WA

Tel: 360-669-8746
FAX: 360-699-8751

AVX North Central, IN

Tel: 317-848-7153
FAX: 317-844-9314

AVX Northeast, MA

Tel: 508-485-8114
FAX: 508-485-8471

AVX Mid-Pacific, CA

Tel: 408-436-5400
FAX: 408-437-1500

AVX Southwest, AZ

Tel: 602-539-1496
FAX: 602-539-1501

AVX South Central, TX

Tel: 972-669-1223
FAX: 972-669-2090

AVX Southeast, NC

Tel: 919-878-6357
FAX: 919-878-6462

AVX Canada

Tel: 905-564-8959
FAX: 905-564-9728

EUROPE

AVX Limited, England European Headquarters

Tel: ++44 (0)1252 770000
FAX: ++44 (0)1252 770001

AVX S.A., France

Tel: ++33 (1) 69.18.46.00
FAX: ++33 (1) 69.28.73.87

AVX GmbH, Germany - AVX

Tel: ++49 (0) 8131 9004-0
FAX: ++49 (0) 8131 9004-44

AVX GmbH, Germany - Elco

Tel: ++49 (0) 2741 2990
FAX: ++49 (0) 2741 299133

AVX srl, Italy

Tel: ++390 (0)2 614571
FAX: ++390 (0)2 614 2576

AVX sro, Czech Republic

Tel: ++420 (0)467 558340
FAX: ++420 (0)467 558345

ASIA-PACIFIC

AVX/Kyocera, Singapore Asia-Pacific Headquarters

Tel: (65) 258-2833
FAX: (65) 350-4880

AVX/Kyocera, Hong Kong

Tel: (852) 2-363-3303
FAX: (852) 2-765-8185

AVX/Kyocera, Korea

Tel: (82) 2-785-6504
FAX: (82) 2-784-5411

AVX/Kyocera, Taiwan

Tel: (886) 2-2516-7010
FAX: (886) 2-2506-9774

AVX/Kyocera, China

Tel: (86) 21-6249-0314-16
FAX: (86) 21-6249-0313

AVX/Kyocera, Malaysia

Tel: (60) 4-228-1190
FAX: (60) 4-228-1196

Kyocera Elco, Japan

Tel: 045-943-2906/7
FAX: 045-943-2910

Kyocera, Japan

Tel: (81) 75-593-4518
FAX: (81) 75-502-2705

Contact:



00-8016-020-000-
007

60-8017-0633-00-
339

00-8016-120-000-
001

EN - For pricing and availability in your local country please visit one of the below links:

DE - Informationen zu Preisen und Verfügbarkeit in Ihrem Land erhalten Sie über die unten aufgeführten Links:

FR - Pour connaître les tarifs et la disponibilité dans votre pays, cliquez sur l'un des liens suivants:

[00-8016-038-000-001](#)

[00-8016-056-000-001](#)

[00-8016-038-000-007](#)

[60-8017-0513-00-339](#)

[00-8016-020-000-001](#)

EN

This Datasheet is presented by the manufacturer

DE

Dieses Datenblatt wird vom Hersteller bereitgestellt

FR

Cette fiche technique est présentée par le fabricant