

## I10 series relays

Circuit Schematics	Maximum Switch Ratings			Nom VDC	Logic Driver	Coil $\Omega$	Type 110	Form
	Volts DC	Amps	Watts DC					
	200	0.5	10	5 12 24	14mA	375 1000 2000	111A-1 111A-2 111A-3	1 FORM A
	28	0.25	3	5 12 24	14mA	375 1000 2000	111C-1 111C-2 111C-3	1 FORM C
	200	0.5	10	5 12 24	14mA	375 1000 2000	111B-1 111B-2 111B-3	1 FORM B
	200	0.5	10	5 12 24		250 1000 2000	112A-1 112A-2 112A-3	2 FORM A
	28	0.25	3	5 12 24		250 1000 2000	112C-1 112C-2 112C-3	2 FORM C
	200	0.5	10	5 12 24		125 800 2000	113A-1 113A-2 113A-3	3 FORM A
	28	0.25	3	5 12 24		125 800 2000	113C-1 113C-2 113C-3	3 FORM C
	200	0.5	10	5 12 24		125 800 2000	114A-1 114A-2 114A-3	4 FORM A
	—	—	—	—		—	—	1 FORM C Latching

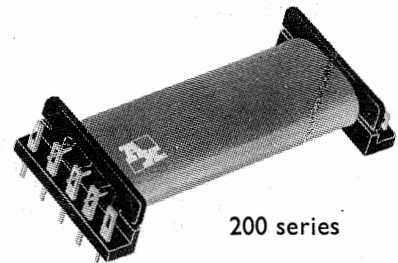

I10 series



200 series

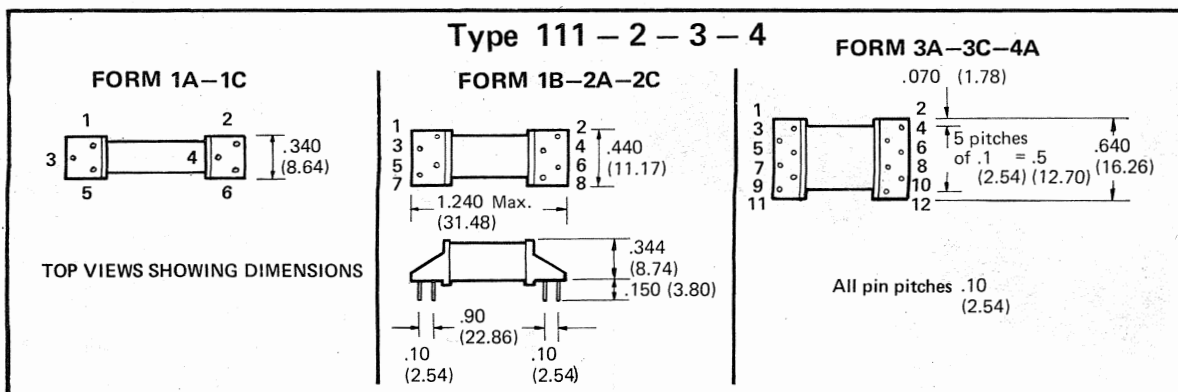

## I20, I30 and I50 series, dual in line reed relays

Form	Type 120	Type 130	Coil $\Omega$	Logic Driver	Nom. VDC	Maximum Switch Ratings			Diode	CIRCUIT SCHEMATICS
	14 pin	8 pin				Watts DC	Amps	Volts		
1 Form A Rhodium	121A-3	131A-3	500	10mA	5	10	0.50	100	—	
	121A-4	131A-4	500	10mA	5				Yes	
	121A-5	131A-5	2900		12-24				—	
	121A-6	131A-6	2900		12-24				Yes	
1 Form B Rhodium	121B-3	131B-3	500	10mA	5	10	0.50	100	—	
	121B-4	131B-4	500	10mA	5				Yes	
	121B-5	131B-5	2900		12				—	
	121B-6	131B-6	2900		12				Yes	
1 Form C Rhodium	121C-1	131C-1	80	80mA	5	3	0.25	28	—	
	121C-2	131C-2	80	80mA	5				Yes	
	121C-3	131C-3	450		12				—	
	121C-4	131C-4	450		12				Yes	
	121C-5	131C-5	1750		24				—	
	121C-6	131C-6	1750		24				Yes	
2 Form A Rhodium	122A-1	132A-1	200	40mA	5	3	0.11	28	—	
	122A-2	132A-2	200	40mA	5				Yes	
	122A-3	132A-3	500		12				—	
	122A-4	132A-4	500		12				Yes	
	122A-5	132A-5	2150		24				—	
	122A-6	132A-6	2150		24				Yes	
1 Form C Rhodium	125C-1	135C-1	150	40mA	5	5	0.50	50	—	
	125C-2	135C-2	150	40mA	5				Yes	
	125C-3	135C-3	500		12				—	
	125C-4	135C-4	500		12				Yes	
	125C-5	135C-5	2150		24				—	
	125C-6	135C-6	2150		24				Yes	
<b>4 PIN VERSIONS</b>										
1 Form A Rhodium	141A-3	4 Pin ½ DIL	500	10mA	5	10	0.50	100	—	
	141A-4		500	10mA	5				Yes	
	141A-5		2900		12-24				—	
	141A-6		2900		12-24				Yes	
1 Form A Rhodium	147A-1	4 Pin ½ DIL	200	40mA	5	10	0.50	500	—	
	147A-2		200	40mA	5				Yes	
1 Form A Rhodium	151A-1	4 Pin DIL	200	40mA	5	10	0.50	100	—	
	151A-2		200	40mA	5				Yes	

### DIMENSIONS 120/130/150 D.I.L.

120 Series has all pins as shown.

130 Series has pins 1,2,6,7,8,9,13,14 only

150 Series has pins 2,6,8,14 only

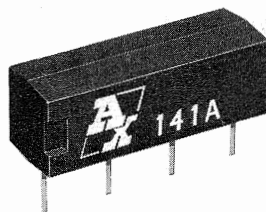
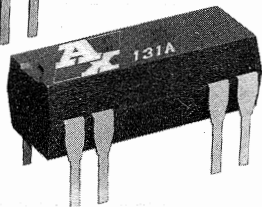
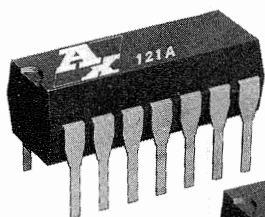
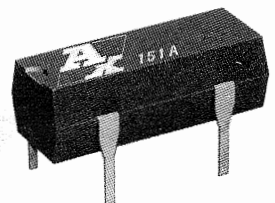
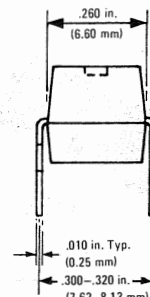
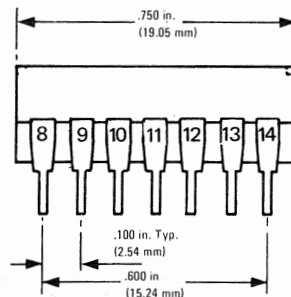
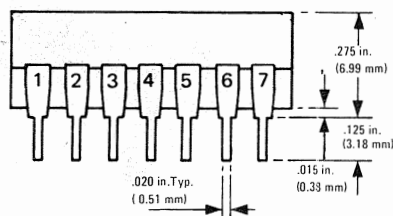

### DIMENSIONS 141/147 ½ DIL

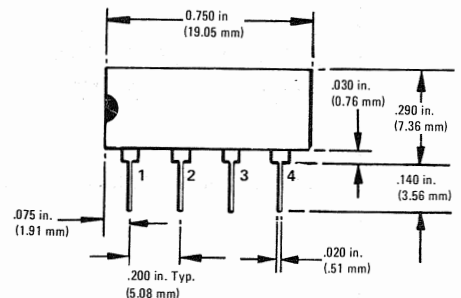
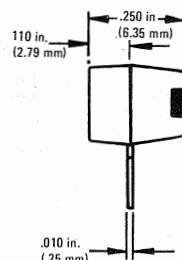

## 170 and 180 series reed relays

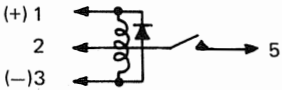
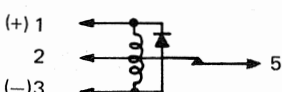
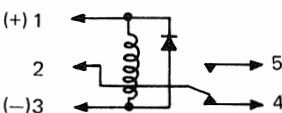
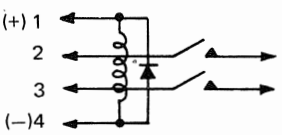
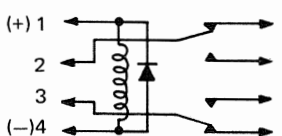
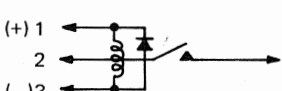
Form	Type 170 0.150" Centres (3.81)	Type 180 0.100" Centres (2.54)	Coil $\Omega$	Logic Driver	Nom. VDC	Maximum Switch Ratings			Diode	Circuit Schematics
						Watts DC	Amps	Volts DC		
1 Form A Rhodium	171A-3	181A-3	500	10mA	5	10	0.50	200	—	
	171A-4	181A-4	500	10mA	5				Yes	
	171A-5	181A-5	1000		12				—	
	171A-6	181A-6	1000		12				Yes	
	171A-7	181A-7	2000		24				—	
	171A-8	181A-8	2000		24				Yes	
1 Form B Rhodium	171B-3	181B-3	500	10mA	5	10	0.50	200	—	
	171B-4	181B-4	500	10mA	5				Yes	
	171B-5	181B-5	1000		12				—	
	171B-6	181B-6	1000		12				Yes	
	171B-7	181B-7	2000		24				—	
	171B-8	181B-8	2000		24				Yes	
1 Form C Gold	171C-1	181C-1	500	10mA	5	3	0.25	28	—	
	171C-2	181C-2	500	10mA	5				Yes	
	171C-3	181C-3	1000		12				—	
	171C-4	181C-4	1000		12				Yes	
	171C-5	181C-5	2000		24				—	
	171C-6	181C-6	2000		24				Yes	
2 Form A Rhodium	172A-1	182A-1	375	14mA	5	10	0.50	200	—	
	172A-2	182A-2	375	14mA	5				Yes	
	172A-3	182A-3	1000		12				—	
	172A-4	182A-4	1000		12				Yes	
	172A-5	182A-5	2000		24				—	
	172A-6	182A-6	2000		24				Yes	
2 Form C Rhodium	172C-1	182C-1	375	14mA	5	3	0.25	28	—	
	172C-2	182C-2	375	14mA	5				Yes	
	172C-3	182C-3	1000		12				—	
	172C-4	182C-4	1000		12				Yes	
	172C-5	182C-5	2000		24				—	
	172C-6	182C-6	2000		24				Yes	
1 Form A Rhodium	175A-3	—	500	10mA	5	10	0.50	500	—	
	175A-4		500	10mA	5				Yes	
	175A-5		1000		12				—	
	175A-6		1000		12				Yes	
	175A-7		2000		24				—	
	175A-8		2000		24				Yes	

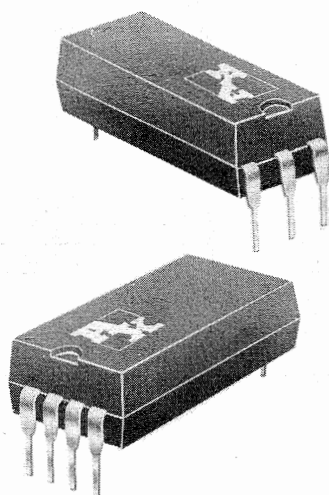

**170 and 180 series reed relays (cont.)**

**Optional Magnetic Shield**

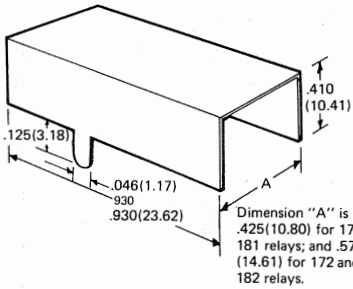

Dimension "A" is .425 (10.80) for 171, 181 relays; and .575 (14.61) for 172 and 182 relays.

Recommended drill pattern for all 172 and 182 relays with magnetic shield, as viewed from the component side of the board.

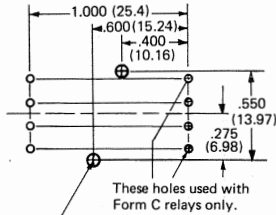

.062 (1.57) dia. hole (2 required)  
These holes used for retaining magnetic shield.

Recommended drill pattern for all 171 and 181 relays with magnetic shield, as viewed from the component side of the board.

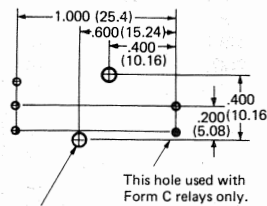

.062 (1.57) dia. hole (2 required)  
These holes used for retaining magnetic shield.

**All 171 Relays**  
(one pole, .150" grid)

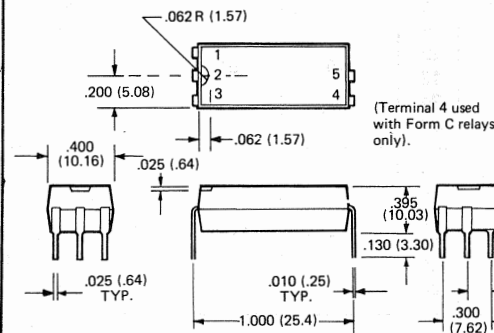

**All 172 Relays**  
(two poles, .150" grid)

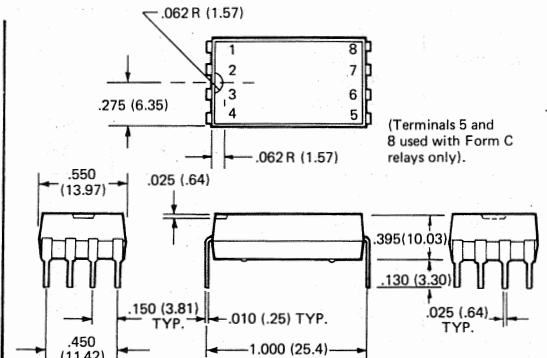

**All 181 Relays**  
(one pole, .100" grid)

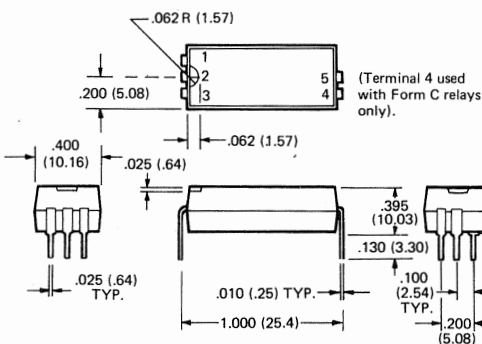

**All 182 Relays**  
(two poles, .100" grid)

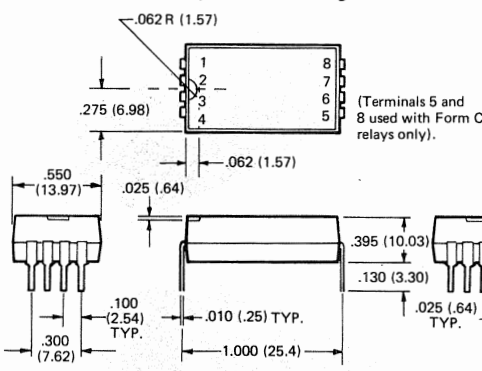

## 200 series relays

Form	Type 200	Coil $\Omega$	Logic Driver	Nom VDC	Maximum Switch Ratings			Circuit Schematics
					Watts DC	Amps	Volts DC	
1 FORM A	201A-1	150		5	15	1.0	400	
	201A-2	1000		12				
	201A-3	2000		24				
1 FORM C	201C-1	150		5	10	0.5	250	
	201C-2	1000		12				
	201C-3	2000		24				
1 FORM B	201B-1	150		5	15	1.0	400	
	201B-2	1000		12				
	201B-3	2000		24				
2 FORM A	202A-1	125		5	15	1.0	400	
	202A-2	800		12				
	202A-3	1900		24				
2 FORM C	202C-1	125		5	10	0.5	250	
	202C-2	800		12				
	202C-3	1900		24				
3 FORM A	203A-1	75		5	15	1.0	400	
	203A-2	275		12				
	203A-3	1000		24				
3 FORM C	203C-1	75		5	10	0.5	250	
	203C-2	275		12				
	203C-3	1000		24				
4 FORM A	204A-1	75		5	15	1.0	400	
	204A-2	275		12				
	204A-3	1000		24				
1 FORM C Latching	201CL-1	150		5	10	0.5	250	
	201CL-2	1000		12				
	201CL-3	2000		24				

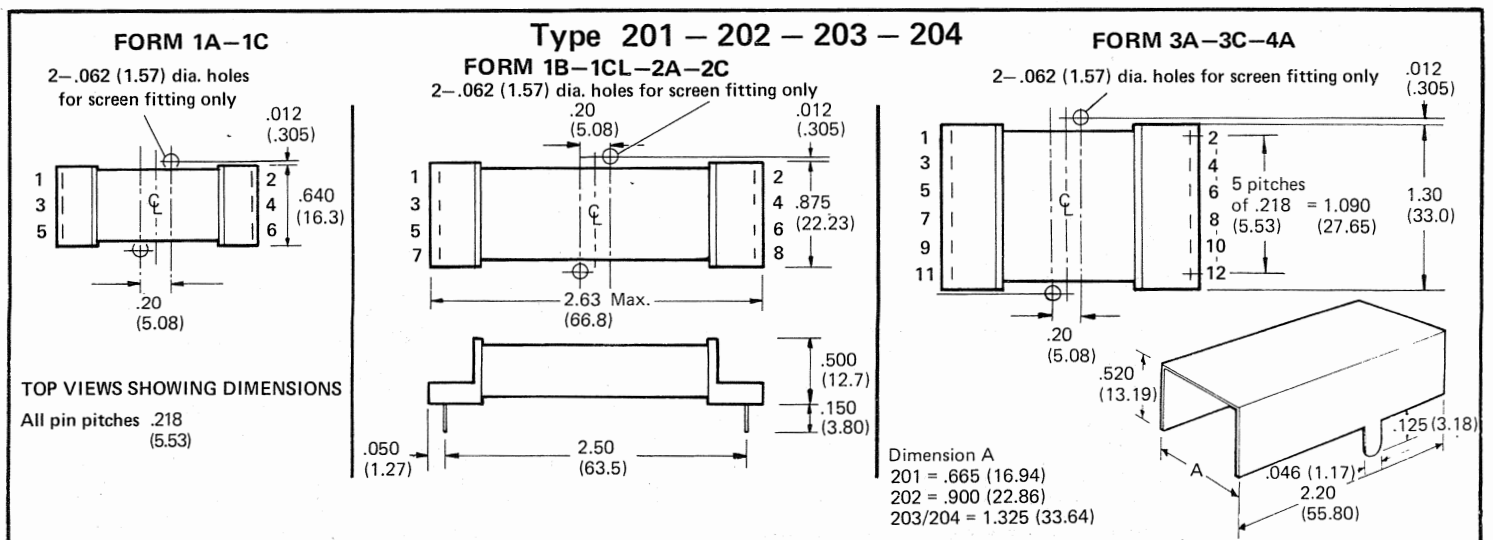

## 1500, 2500, 5500 and 7500 series solid state AC relays

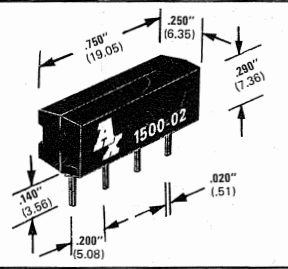
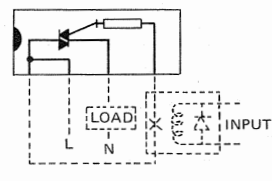
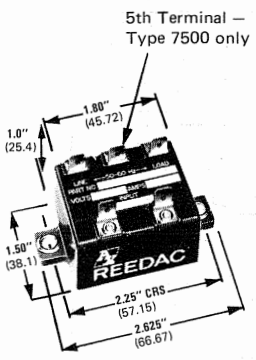
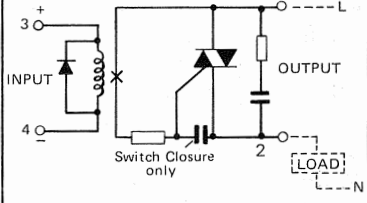
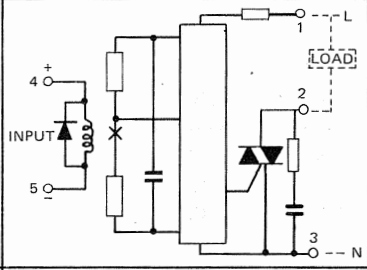
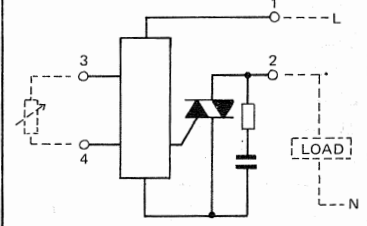
	TYPE	DESCRIPTION	SIMPLIFIED CIRCUIT	Current Rating	Operate Voltage	Coil Res.	TYPE No.
	DIL REEDAC TYPE 1500	½ D.I.L. package embracing latest solid state switching technology.		02	USE 147 ½ DIL REED RELAY		1500-02
	STANDARD REEDAC TYPE 2500	The standard REEDAC is a hybrid heavy duty 50 cycle AC switch which has all the advantages of Reed Relay Switching, Solid State dependability, combined with a 500 million operations life expectancy.  SWITCH CLOSURE - Switch must stand-off 500V at 30 mA		07 15 30	SWITCH CLOSURE		2500-0700 05 12 500 1200 2500-0705 3500-0712 SWITCH CLOSURE 05 12 500 1200 2500-1505 2500-1512 SWITCH CLOSURE 05 12 500 1200 2500-3000 2500-3005 2500-3012
	SYNCHRO REEDAC TYPE 7500	The synchro-REEDAC circuit prevents "½ wave phenomena" and delivers virtually zero RFI. Turn-on occurs no later than 4V into the cycle and turn-off at current zero.  SWITCH CLOSURE - Switch must stand-off 20V at 30 mA		07 15 30	SWITCH CLOSURE		7500-0700 05 12 500 1200 7500-0705 7500-0712 SWITCH CLOSURE 05 12 500 1200 7500-1505 7500-1512 SWITCH CLOSURE 05 12 500 1200 7500-3000 7500-3005 7500-3012
	PHASE CONTROL REEDAC TYPE 5500	The Phase-Control REEDAC is a low cost, low loss AC voltage controller ideal for:-- Simple Speed Control Light Dimmers or any automatic application requiring variable voltage controlled by a resistive input:-- i.e. Potentiometer Thermistor etc.		07 15 30	500K POTENTIOMETER		5500-0701 5500-1501 5500-3001

### Absolute Maximum Ratings

	05	12	UNIT
INPUT VOLTAGE @ 25° C	15.5	24	V
MAXIMUM CONTINUOUS VOLTAGE	±500	±500	V
PEAK INPUT VOLTAGE	±500	±500	V
REPETITIVE OFF-STATE VOLTAGE	07	7	A
	15	15	A
	30	30	A
PEAK ON-STATE CURRENT	SEE SURGE CURRENT CHART FIG. 2		
INPUT TO OUTPUT VOLTAGE	1500	1500	VAC
OPERATING TEMPERATURE	0 to 100	0 to 100	°C
STORAGE TEMPERATURE	-40 to +125	-40 to +125	°C
RECOMMENDED OPERATING CONDITIONS	MIN.	MAX.	UNIT
OFF-STATE RMS OUTPUT VOLTAGE	24	280	V
OUTPUT FREQUENCY	45	65	HZ
BASE PLATE TEMPERATURE RANGE	0	100	°C

### Electrical Characteristics @ 25°C Operating Base Plate Temp.

	05		12		
	Min.	Max.	Min.	Max.	
VOLTS (OFF) MIN. VOLTAGE-OUTPUT OFF	.5	-	1.0	-	V
VOLTS (ON) MAX. INPUT VOLTAGE-OUTPUT ON	-	3.7	-	8.0	V
DV/DT CRITICAL RATE OF RISE (OFF-STATE)	MIN.		TYP		MAX.
	25		100		500
DV/DT (COMMUTATING)	2		10		25
RMS SURGE (I <sup>2</sup> T)	2 AMP	-	-	-	20
	7 AMP	-	-	-	70
	15 AMP	-	-	-	150
	30 AMP	-	-	-	500

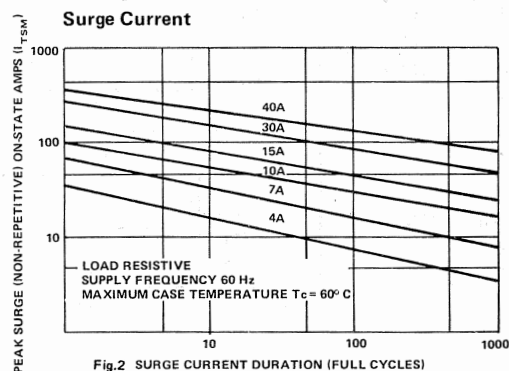
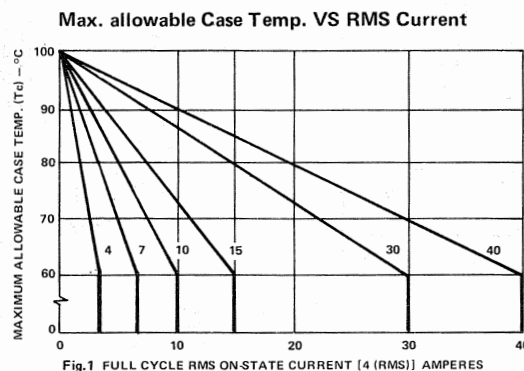

*....the connoisseur's choice*

**KEYSWITCH**

*the relay company*

## KMK Miniature Relays

KMK standard relay, with coil tags protruding from either side of the coil on the three changeover relay.

Life In excess of 5 million operations (mechanical life).

Certain types are DEMKO, CSA and BSI approved

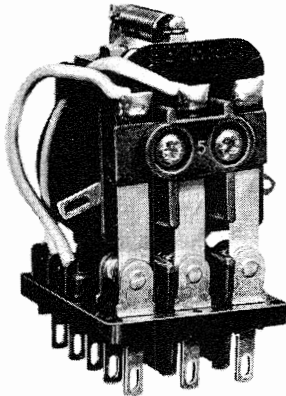

### Contacts

Functions: One, two and three changeover contacts.

Materials: Pure silver contacts fitted as standard. Silver cadmium oxide contacts fitted for higher ratings.

Times: Operate A.C. 20 mS. D.C. 30 mS. Release A.C. 20 mS. D.C. 20 mS.

Ratings: See table.

### Coils

Windings: Single windings.

Resistance: From 6 Ω up to 10,000 Ω.

Voltage: Standard A.C./D.C. voltages, see table below.

Consumption: 1.25W D.C. or 2.5VA A.C.

Assembly: High grade low carbon magnetic iron used throughout. Magnetic circuit moulded D.A.P. assembly.

Insulation: 2,000V A.C.

### Specification

#### COIL OPERATION

*Rated Voltage (V)	Rated Current (mA)	Resistance (Ω)
AC 50-60 Hz	6	400
	12	206
	24	100
	48	45
	230	11
DC	6	200
	12	95
	24	47
	48	24
	100	11
	200	11
		Series 10KΩ 2W

\* Coil Voltage Operating Range 80%-110% of Rated Voltage.

### KMK1 KMK1H

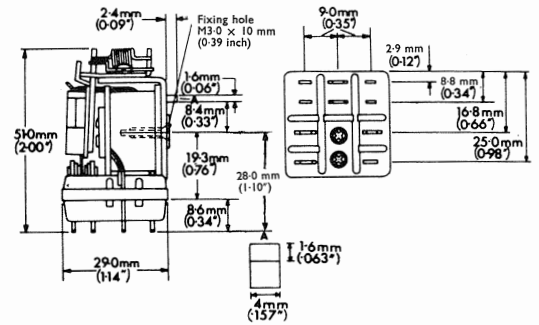
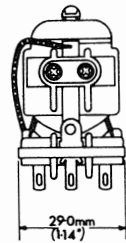

### KMK2 KMK2H

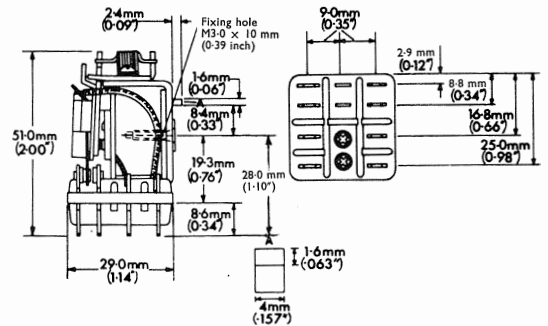
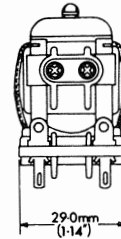

### KMK3 KMK3H

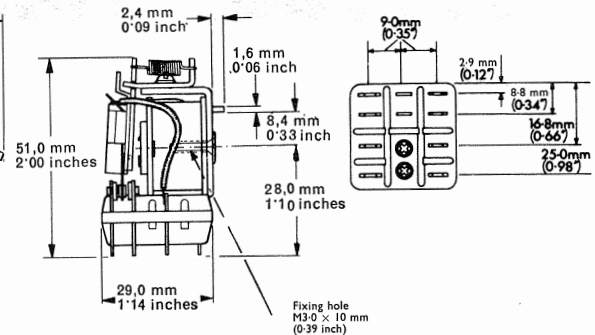
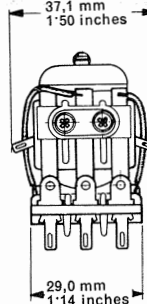

#### MAXIMUM CONTACT LOAD

** Voltage (V)	RATED CURRENT (A)			
	KMK1 and KMK2		KMK3	
	Resistive Load cos φ 1	Inductive Load cos φ 0.4	Resistive Load cos φ 1	Inductive Load cos φ 0.4
AC to 250 to 440	7.5	3	5	2
	3	1.5	2	1
DC	6	7.5	5	4.6
	12	7	4.6	4.4
	24	4.5	3	2.6
	48	1.5	1	0.7
	100	0.3	0.22	0.1
	200	0.15	0.11	0.1
250	0.1	‡	0.07	‡

\*\* Maximum contact rating for silver cadmium oxide contacts is 10A @ 250V a.c./6V d.c. for 1 and 2 Changeover. 7A @ 250V a.c./6V d.c. for 3 Changeover.

‡ Time Constant 60 mS

## KMKP Plug-in Relays

Certain types are DEMKO, CSA and BSI approved

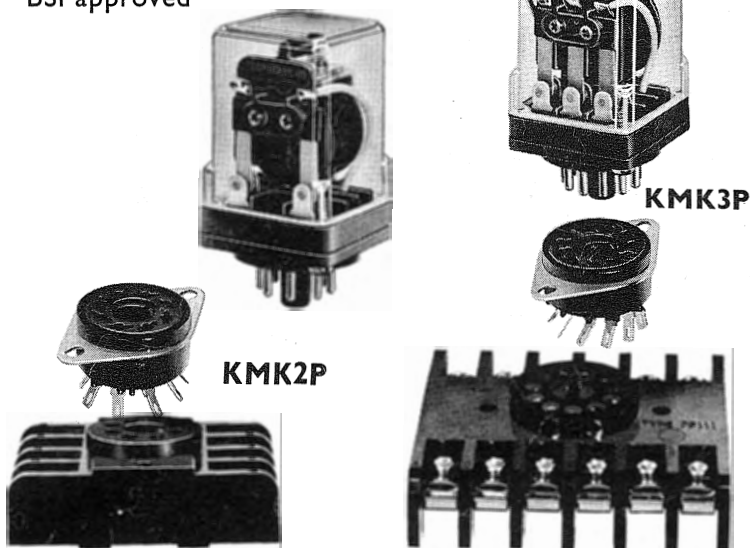

### KMK2P KMK2PH

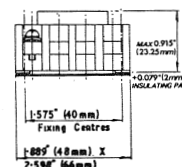
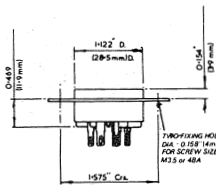
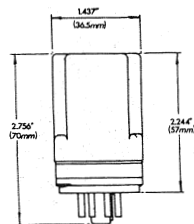

### KMK3P KMK3PH

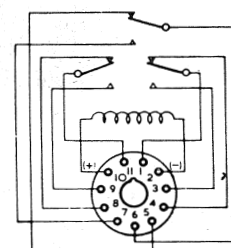
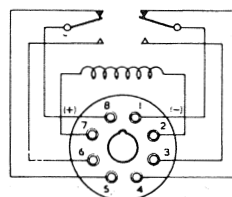
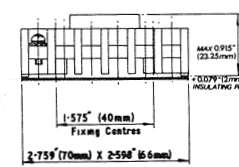
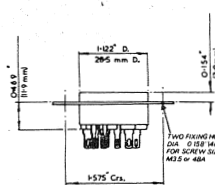
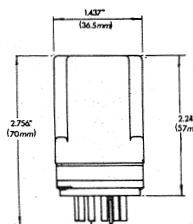

### Coils

Windings: Single windings.

Resistance: From 6 Ω up to 9,350 Ω.

Voltage: Standard A.C./D.C. voltages, see table below.

Consumption: 1.25W D.C. or 2.5VA A.C.

Assembly: High grade low carbon magnetic iron used throughout. Magnetic circuit moulded D.A.P. assembly.

Insulation: 2,000V A.C.

### Contacts

Functions: Two and three changeover contacts with 4 mm clearance.

Materials: Pure silver contacts fitted as standard. Silver cadmium oxide contacts fitted for higher ratings.

Timings: Nominal operate A.C. 20 ms. D.C. 30 ms. Release A.C. 20 ms. D.C. 20 ms.

Ratings: See table below.

### COIL OPERATION

* Rated Voltage (V)	Rated Current (mA)	Resistance (Ω)
6	400	6
AC 12	206	25
50-60 Hz 24	100	98
50	45	390
110	26	1,590
230	11	7,400
6	200	30
12	95	128
DC 24	47	510
48	24	2,050
100	11	9,350
200	11	9,350
		Series 10KΩ 2W

\* Coil Voltage Operating Range = 80%—110% of Rated Voltage.

### Connections

Standard socket for solder/push-on connectors size 0.110×0.016 inches (types CPI058/8 and CPI058/11). Front connection socket with screw terminals (types KF8 and KF11). Printed circuit sockets (types KPBI058/06 and KPBI058/08). Spring Retaining Clips (KP91127) available, fitting all KMKP relays with any of the associated sockets. **Life** in excess of 5 million operations (Mechanical).

MAXIMUM CONTACT LOAD		RATED CURRENT (A)			
** Voltage (V)		KMK2P		KMK3P	
		Resistive Load cos φ	Inductive Load I cos φ 0.4	Resistive Load cos φ	Inductive Load I cos φ 0.4
AC	to 250 to 440	5.0 2.0	2.0 1.0	3.3 1.3	1.3 0.6
DC	6 12 24 48 100 200 250	5.0 4.6 3.0 1.0 0.2 0.1 0.07	4.6 4.4 2.6 0.7 0.14 0.07 ‡	3.3 3.0 2.0 0.6 0.13 0.06 0.05	3.0 2.0 1.6 0.48 0.08 0.048 ‡

\*\* Maximum contact rating for silver cadmium oxide contents is 7.6A (KMK2P) and 5A (KMK3P).

‡ Time Constant 60 ms.

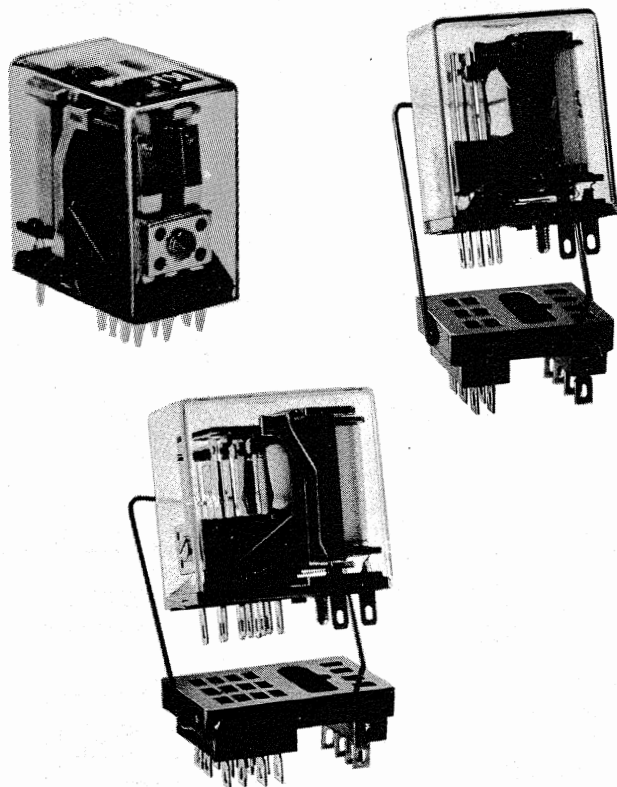
**SMP Subminiature Relays**

**Contact rating**

(i) Light duty (gold flashed) silver contacts rated 1A or 100V D.C. (max. 30W). (ii) Heavy duty silver contacts rated 5A or 270V D.C. (max. 100W), 100W at 30V D.C.; 80W at 50V D.C.; 50W at 270V D.C.

**Coil dissipation at 40 °C**

Maximum volts with minimum resistance: less than 1.5W.  
Nominal volts with nominal resistance: from 0.6 to 1W.

Minimum volts with nominal resistance: Two pole relays from 0.13 to 0.25W. All other relays from 0.3 to 0.5W.

**Coil range**

D.C. coil voltages up to 120V D.C. (15,000 $\Omega$ ).

**Contact range**

Makes (Form A), breaks (Form B), changeover (Form C) and "k" actions (make before break Form D).

Twin (bifurcated) contacts can be fitted to light duty relays where specified.

**Life (Mechanical)**

Light duty contacts in excess of 100 million operations.  
Heavy duty contacts in excess of 1 million operations.

**Connection**

SMP-solder direct to tags or plug-into associated sockets with solder or printed circuit connections. SM-directly into printed circuit boards.

**Insulation**

Light duty relays are voltage proof of 50 Hz 500V RMS.  
Heavy duty relays are voltage proof at 50 Hz 1,000V RMS.

**Contact times**

Operate: 6–10 mS. depending on type.

Release: 3–4 mS. depending on type.

**Associated sockets for plug-in Relays (SMP)**

All sockets are supplied with a spring retaining clip.

SM2P Relays—Sockets with solder connections—1351-01.  
Sockets with printed circuit connections—1352-01.

SM4P and SM6P Relays—Sockets with solder connections—1351-02. Sockets with printed circuit connections—1352-02.

SM6P (6 changeover) relay—Sockets with solder connections—"CS". Sockets with printed circuit connections—"CP".

**Specification 2, 4 and 6 pole Relays (excluding 6 changeover)**

Nominal Operating Voltage	Nominal Coil Resistance ( $\pm 10\%$ at 20 °C Amb.)	OPERATING VOLTAGES			OPERATING CURRENTS			NOMINAL COIL INDUCTANCE		
		Minimum		Max.	Minimum		Max.	Armature open	Armature closed	Armature Energised at Normal
		Two fine silver contacts	Four & six fine silver or 5A contacts	All types	Two fine silver contacts	Four & six fine silver or 5A contacts	All types			
(V D.C.)	( $\Omega$ )	(V D.C.)	(V D.C.)	(V D.C.)	(mA)	(mA)	(mA)	at 50 Hz in Henries		
6	52	2.6	4.0	8.0	50	76	154	0.35	0.25	0.07
10	130	4.4	6.5	13.0	34	50	100	1.6	0.6	0.16
12	185	5.0	8.0	16.0	27	43	85	2.0	0.8	0.2
21	430	8.0	12.0	24.0	19	25	55	4.0	2.0	0.5
26	700	11.0	16.0	31.0	16	23	44	6.0	3.0	0.7
34	1,250	15.0	22.0	40.0	12	18	32	9.0	5.0	1.2
47	2,500	21.0	31.0	56.0	8	12	22	15.0	9.0	2.5
72	5,800	33.0	50.0	86.0	6	9	15	35.0	21.0	6.0
120	15,000	58.0	86.0	138.0	4	6	9	67.0	41.0	13.0

## SMP Dimensional diagrams

### Two pole relays

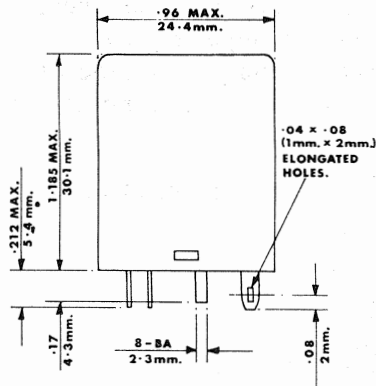

RELAY ONLY

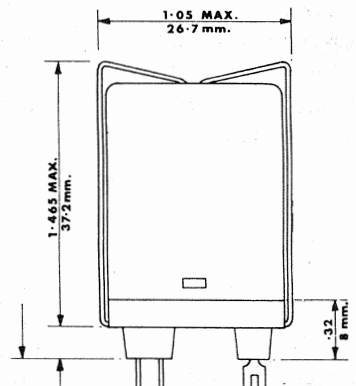

SOCKET TERMINALS WITH .04 X .08 (1mm X 2mm.) ELONGATED HOLES.

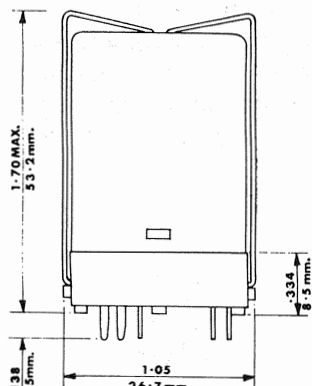

RELAY & PRINTED CIRCUIT SOCKET

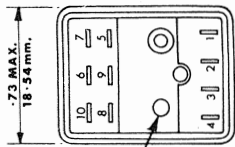

RELAY & STANDARD SOCKET

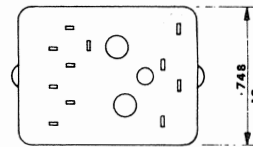

PRINTED CIRCUIT SOCKET UNDERNEATH VIEW

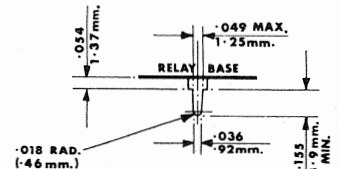

DIRECT MOUNTED PRINTED CIRCUIT TERMINAL

PIP .09 DIA. (2.3mm.) X .025/.02 (.63mm. X .5mm.) HIGH.

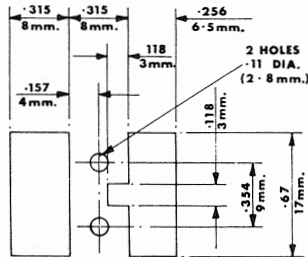

PANEL MOUNTING CUTOUT

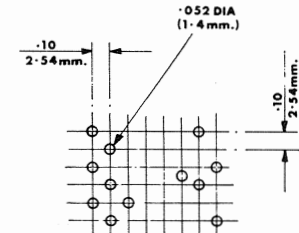

PRINTED CIRCUIT GRID TOP VIEW

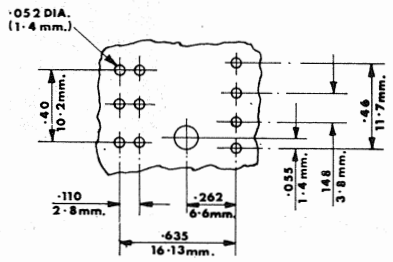

SPECIAL GRID FOR DIRECT MOUNTING TOP VIEW

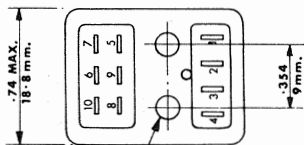

2 HOLES .12 DIA. (3mm.) STANDARD SOCKET UNDERNEATH VIEW

EARTHING CLIP IF REQUIRED

### Four pole and six pole relays

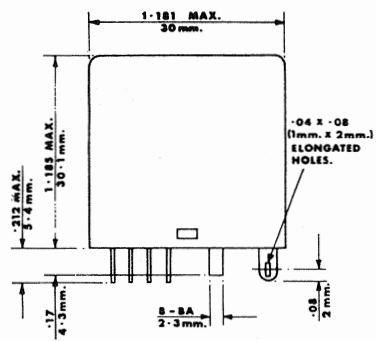

RELAY ONLY

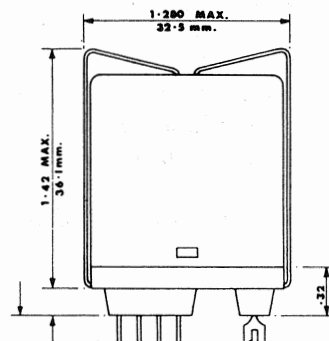

SOCKET TERMINALS WITH .04 X .08 (1mm X 2mm.) ELONGATED HOLES.

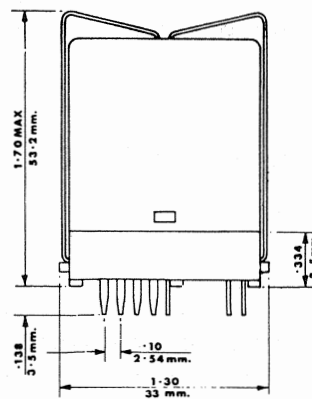

RELAY & PRINTED CIRCUIT SOCKET

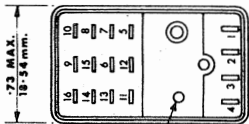

RELAY & STANDARD SOCKET

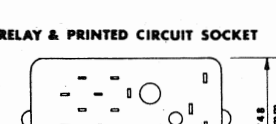

PRINTED CIRCUIT SOCKET UNDERNEATH VIEW

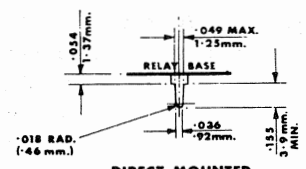

DIRECT MOUNTED PRINTED CIRCUIT TERMINAL

PIP .09 DIA. (2.3mm.) X .025/.02 (.63mm. X .5mm.) HIGH.

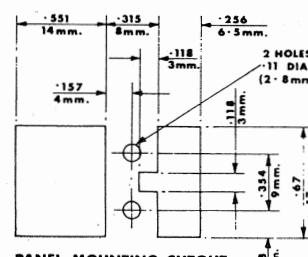

PANEL MOUNTING CUTOUT

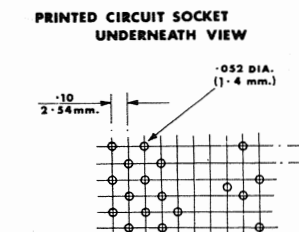

PRINTED CIRCUIT GRID TOP VIEW

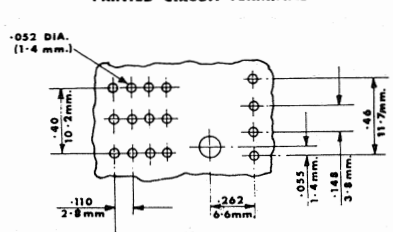

SPECIAL GRID FOR DIRECT MOUNTING TOP VIEW

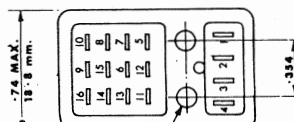

2 HOLES .12 DIA. (3mm.) STANDARD SOCKET UNDERNEATH VIEW

EARTHING CLIP IF REQUIRED

## 1051 Subminiature Snap action switch relay

Type 1051 subminiature relay is light, compact and has long service life: 1,000,000 operations mechanically. Incorporating the snap action mechanism of the high performance subminiature switch, they are suitable for

advanced control systems and feature reliable and accurate operation irrespective of the level of input signals. Open type, with solder connections and plug-in type with solder, push-on, printed circuit or screw type connections are available.

### 1051 Open type

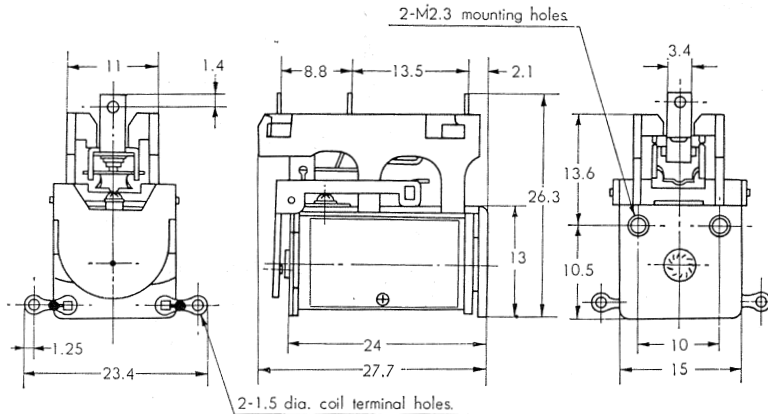
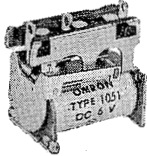

Dimensions (mm)

### 1051P Plug-in type

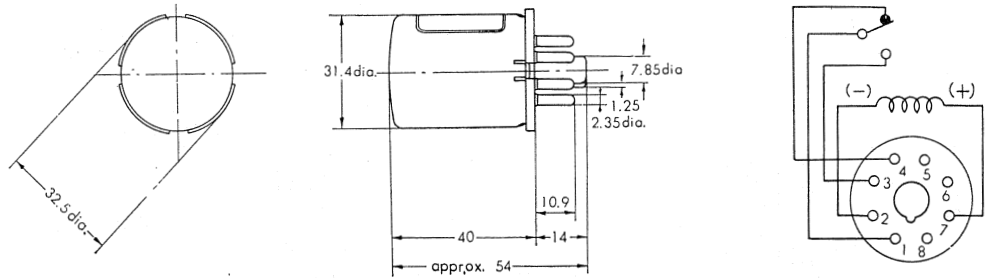

Connecting socket: CPI058/8 back-connecting, KF8 front connecting socket, KPB1058/06 printed circuit.

### Characteristics

Insulation resistance: More than 20M $\Omega$  (open type), 10M $\Omega$  (plug-in type) measured with 500V D.C., Megger.  
 Dielectric strength: 1,000 A.C., for one minute. 600V A.C., between contacts.  
 Vibration: 10g 55 cps.  
 Shock: 25G.  
 Operating frequency: Withstand 1,800 switching operations per hour.  
 Power consumption: about 300 mW.

### Response time:

Operating time: Nominal 50 msec.  
 Resetting time: 25 msec.

### Service life:

Electrically: 30,000 operations min. (under maximum permissible load).  
 100,000 operations min. (60% of maximum permissible load).  
 Mechanically: 1,000,000 operations min.

### Ratings

Coil		Performance characteristics			Maximum permissible load				
Rated voltage (V)	Rated current (mA)	Maximum continuously applicable voltage (% of rated value)	Must operate voltage (% of rated value)	Must drop out voltage (% of rated value)	Inrush current (resistive load) (A) @250V A.C.	Continuously passable current (A) @250V A.C.	Voltage (V)	Breaking current (resistive load) (A)	
								Open type 1051	Plug-in type 1051P
D.C. 6	50	120	80	10	7.5	5	A.C. 250	5	3-5
12	26						480		
24	13.5						D.C. 24	2.5	1.7
48	8.3						100		
		250	0.20	0.14					

Note. The values of must operate voltage are those at a coil temperature of 20 °C (68 °F).  
 2. The rated coil resistance shows values at a coil temperature of 20 °C (68 °F)



## MA miniature contactors

Miniature size with high contact capacity, for resistive and inductive loads. Coloured external plunger to test contact operations mechanically. Attractive dustproof moulded case. Rugged construction requires no maintenance. Twin contacts ensure positive contact action at two points.

**Motor load control.** 1.5 kW inductive load at 440V 3-phase. 0.75kW inductive load at 440V 3-phase.

**Coil range.** Popular voltages up to 440V A.C. (375–480V) 50–60 Hz single phase.

**Connection.** Screw terminals.

**Life:** In excess of 5 million mechanical operations or 500,000 at full electrical load.

**Construction.** Moulded, dustproof casing, giving considerable protection to the contacts during operation.

## Contacts

Functions: MA406 and MA415 both have eight sets of twin contacts. The top four sets “break” when the coil is energised and the bottom sets “make”.

MA406–40 and MA415–40 both have four sets of twin contacts. When the coil is energised the four sets “make” simultaneously.

Materials: Silver contacts.

Timings: Operate: 25 mS. A.C. 50 mS. D.C. Release: 15 mS. A.C. 25 mS. D.C.

Ratings: See table.

## Coils

Resistance: From 1.2Ω up to 5,000Ω.

Voltages: Usual A.C. and D.C. voltages, see table. D.C. relays have external components.

Consumption: MA406 and MA406–40 7.7VA (continuous) 46VA (operating). MA415 and MA415–40 10VA (continuous) 65VA (operating).

Insulation: All contactors are flash tested to 2,000V A.C.

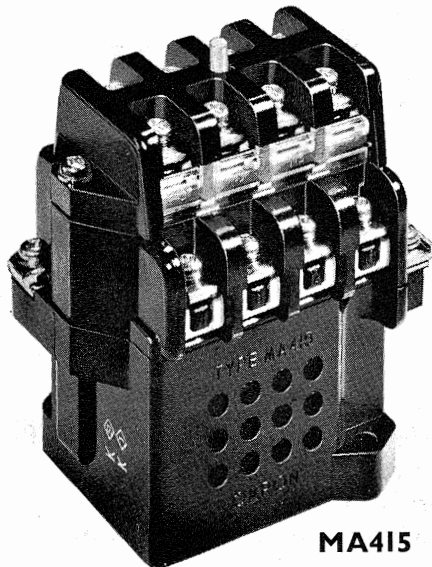

MA415

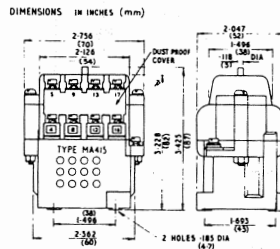

MA406

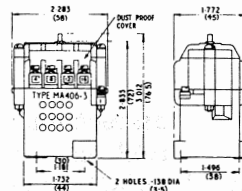

MA406-40

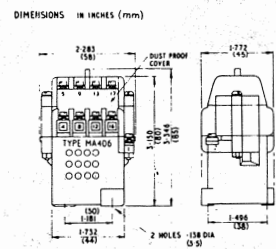

MA415

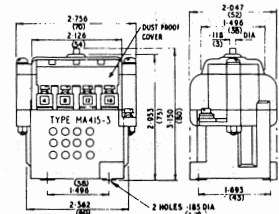

MA415-40

## COIL OPERATION

* Rated voltage (V)	Rated Current (mA)	Resistance	
		Before Operation (Ω)	After Operation (Ω)
A.C. 50–60 Hz	6	1940	0.46
	12	1000	1.37
	24	517	5.42
	50	228	23.5
	100	101	117
	200	50.5	505
400	26.5	2,300	
D.C.	6	960	1.25
	12	475	5.25
	24	240	19
	48	130	77
	100	63	330
	200	31	1,460

## MAXIMUM CONTACT LOAD

Voltage (V)	Rated Current (A)				
	MA415 and MA415-3		MA406 and MA406-3		
	Resistive Load cos φ 1	Inductive Load cos φ 0.4	Resistive Load cos φ 1	Inductive Load cos φ 0.4	
A.C.	110	20	12	8	5
	250	15	10	6	4
	440	8	6	4	3
	500	6	4	3	2
	1,000	4	—	2	—
D.C.	12	15	15	8	8
	24	15	15	8	6
	48	15	10	6	4
	100	10	4	5	2
	200	5	1	2.5	0.5
	1,000	0.05	—	0.03	—

\* Coil Voltage Operating Range=80%–110% of Rated Voltage. A.C. coils are preferred voltages, especially 100V, 200V and 400V a.c.



# KEYSWITCH

# Relays—Contactor



## MM contactor relays

Connections. Solder, plug-in, or screwed terminals.

**Life.** In excess of 5 million mechanical operations and 500,000 electrical, with an inrush current of 60A (less than 15 ms duration) and continuous of 15A. (7.5A plug in).

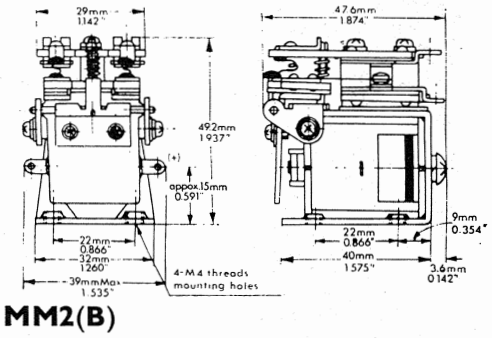
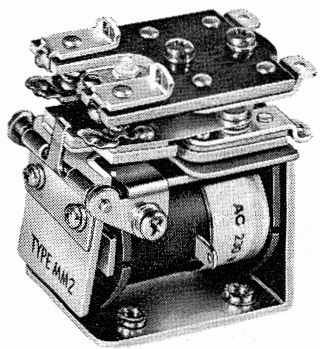

MM2(B)

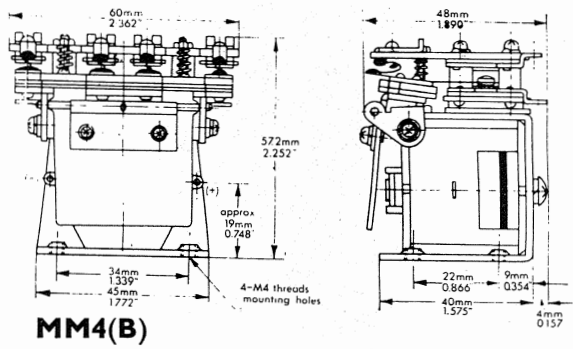

MM4(B)

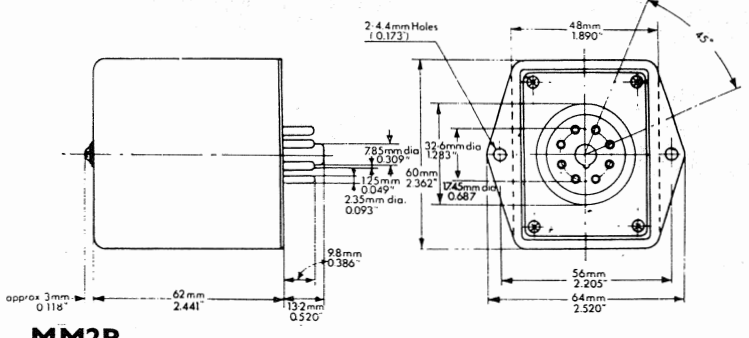

MM2P

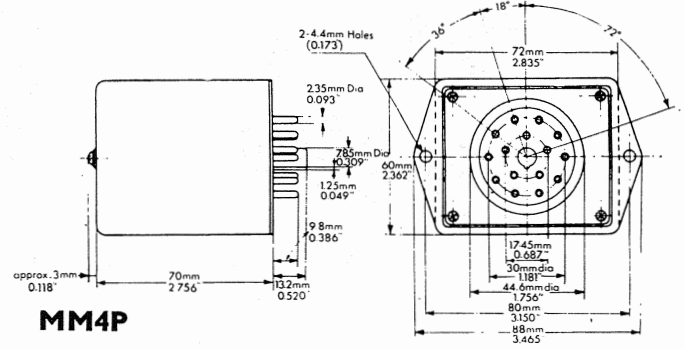

MM4P

## Coils

Resistance: From 0.5Ω up to 15,200Ω (four pole). From 1-4Ω up to 15,500Ω (two pole).  
Voltages: See table.  
Consumption: 3W D.C./7.6VA A.C. Two pole or 3.7W D.C./13VA A.C. on four pole.  
Insulation: All relays flash tested to 1,500V A.C.

## Contacts

Functions: Two or four change-over contacts.  
Timings: Two pole relays: Operate A.C. 20 ms. D.C. 30 ms. Release A.C. 25 ms. D.C. 30 ms. Four pole relays: Operate A.C. 25 ms. D.C. 35 ms. Release A.C. 30 ms. D.C. 35 ms.  
Ratings: Maximum 15A on open relays. Maximum 7.5A on plug-in relays.  
Materials: Ultra fine silver (serrated) 99.9% purity.

## Specification

Motor load control 1.5kW at 200V A.C. Three Phase. 0.2kW at 100V A.C. Single phase.

## COIL OPERATION

*Rated Voltage (V)	Rated Current (mA)		Resistance (Ω)		
	MM2(P)	MM4(P)	MM2(P)	MM4(P)	
	MM2(B)	MM4(B)	MM2(B)	MM4(B)	
A.C. 50-60 Hz	6	935	1,520	1.4	0.5
	12	471	821	5	2
	24	231	396	24	9
	50	113	197	108	42
	110	58	97	453	166
230	29	49	2,008	700	
D.C.	6	260	316	23	19
	12	150	235	80	51
	24	73	104	327	230
	48	38	64	1,260	748
	100	22	30	4,570	3,920
	200	13	13	15,500	15,200

N.B.—Coil operation on MM2B and MM4B relays identical to MM2(P) and MM4(P) relays.

\* Coil Voltage Operating Range=80%-110% of Rated Voltage.

## MAXIMUM CONTACT LOAD

Voltage (V)	RATED CURRENT (A)				
	MM2 and MM4		MM2P and MM4P		
	Resistive cos φ=1	Inductive cos φ 0.4	Resistive cos φ=1	Inductive cos φ 0.4	
A.C.	50	15	15	7.5	7.5
	110	15	15	7.5	7.5
	250	15	8.7	7.5	4.4
	440	2.6	2.0	1.3	1.0
	700	0.26	0.2	0.18	0.15
	D.C.	6	15	15	7.5
12		15	15	7.5	7.5
24		10	10	5.0	5.0
50		3	2	1.5	1.0
100		0.6	0.4	0.3	0.2
220		0.3	0.2	0.15	0.1

N.B.—Maximum contact loads for MM2B and MM4B Relays identical to MM2 and MM4 relays.

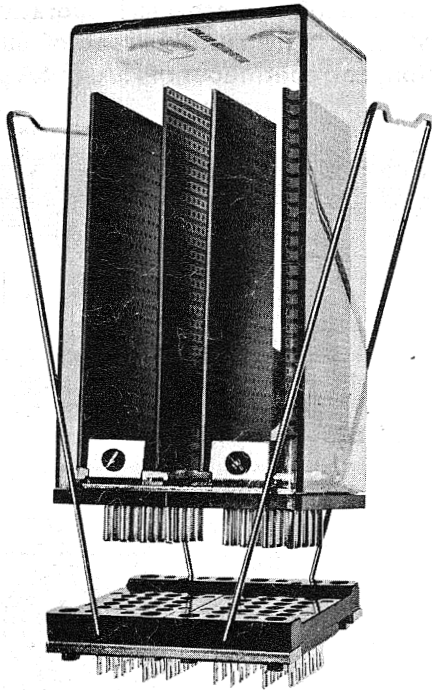

**SERIES-2 CUB (Double Units)**

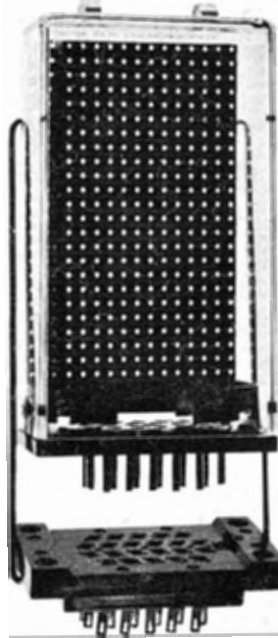

**SERIES-1 CUB (Single Units)**

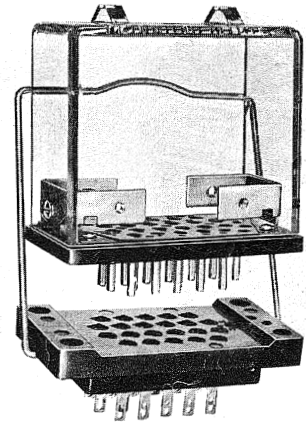

**SERIES-M CUB (Mini Units)**

Visual inspection of components

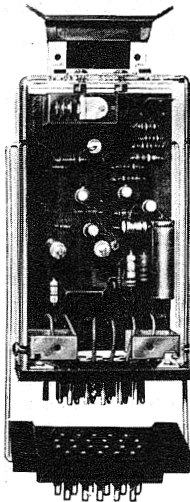

Non-tarnish plug-in pins

Covers in standard, flame retardent or metal (for screening)

Plug-in quick change maintenance

Spring retaining clips in metal or insulated and colour coded

Tags and pins can be gold-plated for switching dry circuits

Replaces edge connectors

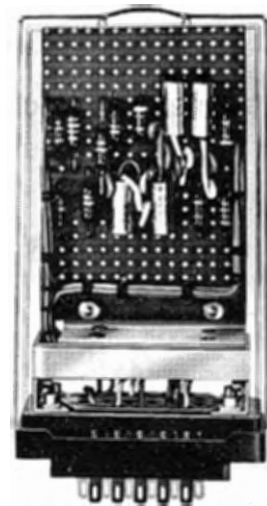

P34 socket solder or push-on tags

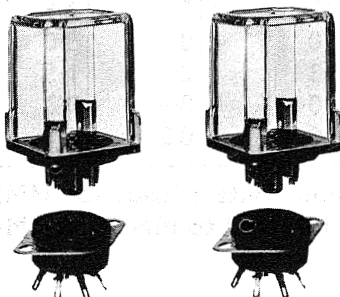

**MINIATURE MODULE UNITS**

8 and 11 pin Component Modules which plug into associated octal type sockets or front connection sockets.

Wire components direct to the pins or mount two sizes of printed circuit board – horizontally or vertically – to fit snugly in the transparent cover.

Cover in flame retardent Polycarbonate.

## TYPES OF UNIT AND DESIGNATIONS

### DOUBLE UNITS (2CUB)

- 2CUB-0: Empty Unit
- 2CUB-1: with ONE Component Board
- 2CUB-2: with TWO Component Boards
- 2CUB-3: with THREE Component Boards
- 2CUB-4: with FOUR Component Boards

### SINGLE UNITS (1CUB)

- 1CUB-0: Empty Unit
  - 1CUB-1: with ONE Component Board
  - 1CUB-2: with TWO Component Boards
- ### MINI UNITS (MCUB)
- MCUB-0: Empty Unit

**Single Units Only:** suffix 'S' for standard, 'F' for flame retardent and 'M' for metal cover.

### COVER: PLUG AND SOCKET

**Material**

(i) Plug:

(ii) Pins and Tags:

**Current Rating:**

**Contact Resistance:**

**Working Voltage:**

**Insulation Resistance:**

**Non-Interchangeability Feature:**

Dustproof transparent polystyrene, flame retardent polycarbonate or metal.

Moulded non-hygroscopic phenolic.

Non-tarnish bright acid tin dipped. Alternative gold plating for dry circuits.

10 amps (mated).

5MΩ (mated).

750V a.c./d.c.

Better than 1,000MΩ at 500V d.c.

Optional extra. This feature should be used where two or more different circuits are built into Keyswitch CUBS. Ensures that only matching plugs and sockets can be mated.

### COMPONENT BOARD

**Material:**

Synthetic resin bonded paper (S.R.B.P.) laminate to which are bonded longitudinal copper strips 0.0015" (0.04mm) thick, spaced at 0.152" (3.81mm<sup>2</sup>) intervals and pierced with a matrix of holes.

**Surface Area:**

**Current Rating:**

(copper strip)

3.610" (91.7mm) x 2.218" (56.35mm).

1 amp with a temperature rise of 1.0°C.

2 amps with a temperature rise of 3.5°C.

3 amps with a temperature rise of 12.0°C.

4 amps with a temperature rise of 24.0°C.

5 amps with a temperature rise of 39.0°C.

**Resistance:** (copper strip)

**Insulation:**

**Breakdown Voltage:** (copper strip) 1,500V d.c.

**Working Voltage:**

Approximately 0.045Ω per inch.

Better than 100MΩ.

Maximum 500V d.c. between adjacent copper strips.

### DIMENSIONAL DIAGRAMS in millimetres

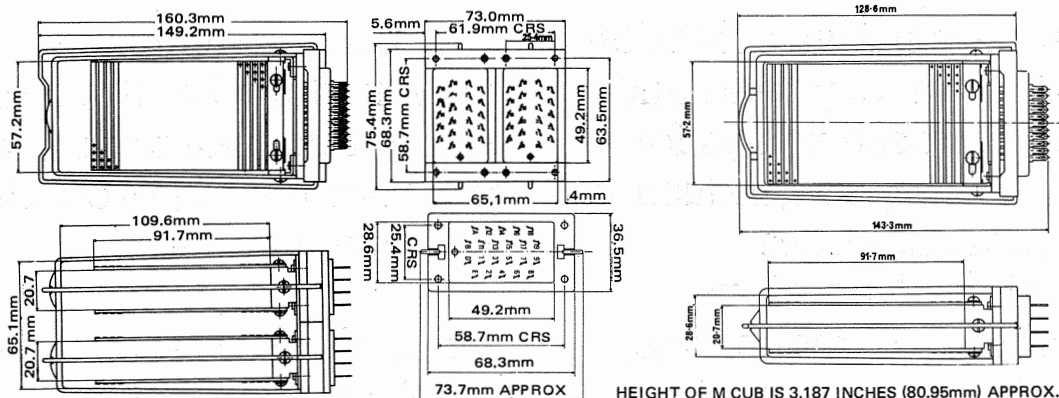

### MINIATURE MODULE UNITS

#### Specification

**COVER:**

**PLUG AND SOCKET**

**Material**

(i) Plug and Socket:

(ii) Pins and Tags:

**Current Rating:**

**Contact Resistance:**

**Working Voltage:**

**Insulation Resistance:**

**WHEN ORDERING**

Dustproof transparent flame retardent polycarbonate.

Moulded non-hygroscopic phenolic.

Bright acid tin dip. Non-Tarnish.

10 amps (mated).

Better than 25MΩ (mated).

440V a.c./d.c.

Better than 100MΩ at 500V d.c.

please specify 8 or 11 pin plug and whether you require the associated sockets

### DIMENSIONAL DIAGRAM in millimetres

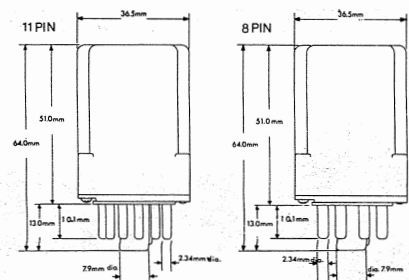

# Relays from Plessey

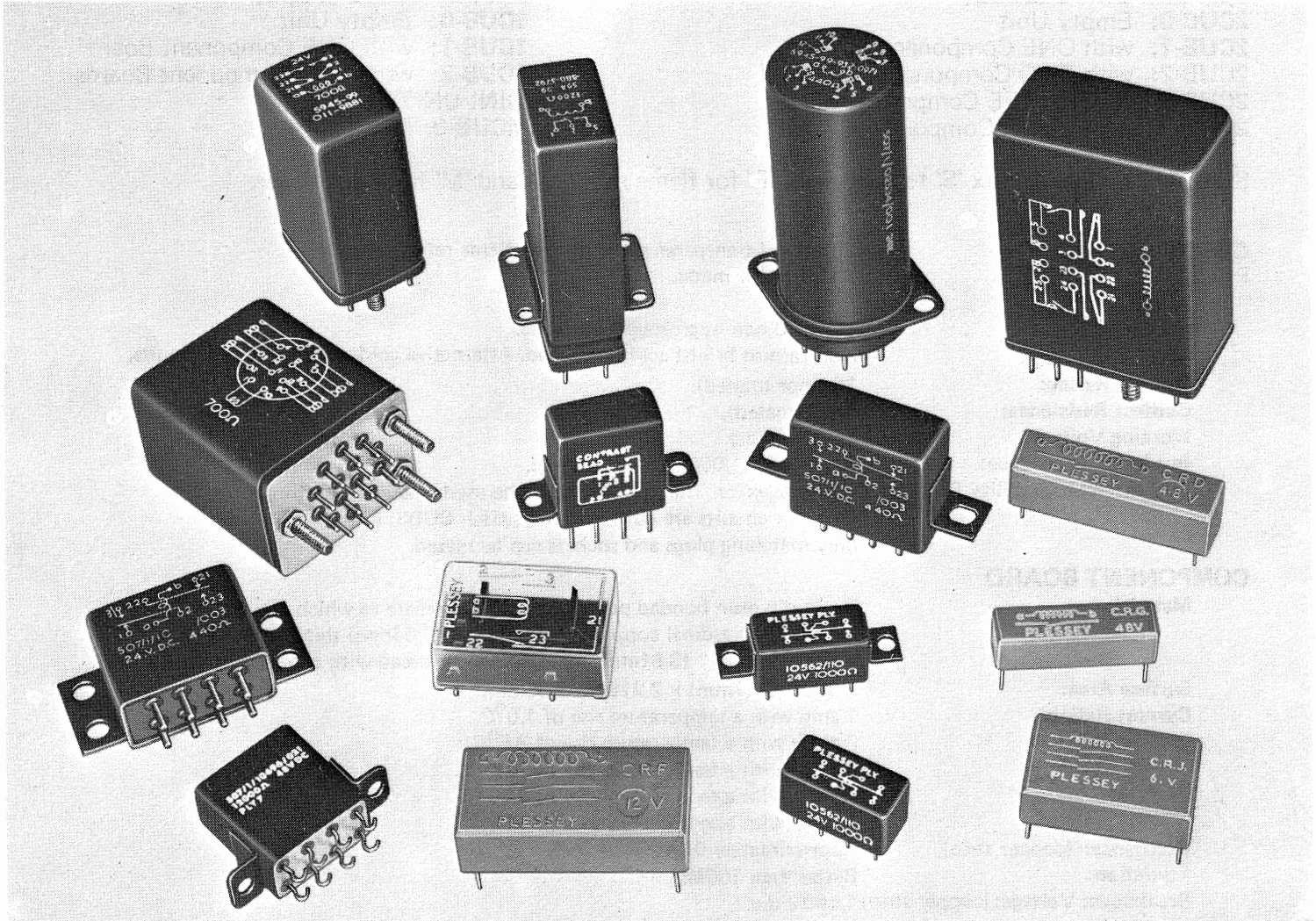

A representative selection of crystal can, dry reed and general purpose relays for military, aerospace, industrial and communications applications. Numerous permutations of mountings, terminals and electrical characteristics are available.

These products are manufactured to the highest standards, maintained by rigorous testing procedures and quality control.

See catalogue for details or ask for a copy of Publication 5426.



## PLESSEY

Plessey Aerospace Electrical Components, Abbey Works, Titchfield, Fareham, Hampshire PO14 4QA  
Tel: Titchfield (03294) 43031 Telex: 86214

**Encapsulated reed relays, types CRD, CRE, CTF, CRG, CRH, CRJ**

The encapsulated reed relay consists of one, two or three single make reed inserts, housed within a coil and encapsulated in polyester.

Magnetic screening is incorporated as standard.

**COIL DATA**

Relay Type	Nominal Coil Volts		Coil Resistance ohms at 20°C	Limit Circuit Current mA	Release Current mA	Hold Current mA
CRD Min. Operate Power at 20°C 50mW	Gold	4.8	215 ±10%	14.1	2.4	10.0
		6.0	330 ±10%	11.5	2.0	8.3
		12.0	1340 ±12½%	5.5	1.0	4.1
		24.0	5050 ±15%	2.9	0.5	2.1
CRE Min. Operate Power at 20°C 100mW	Gold	4.8	120 ±10%	25.2	5.0	17.5
		6.0	185 ±10%	21.0	4.1	14.5
		12.0	765 ±12½%	9.8	2.0	7.1
		24.0	2850 ±12½%	5.3	1.0	3.7
CRF Min. Operate Power at 20°C 175mW	Gold	4.8	66 ±10%	46.0	7.5	31.0
		6.0	90 ±10%	42.0	6.8	28.0
		12.0	365 ±12½%	20.3	3.3	13.5
		24.0	1480 ±12½%	10.0	1.7	6.8
CRG Min. Operate Power at 20°C 110mW	Rhodium or Tungsten	4.8	94.5 ±10%	32.0	2.5	* 15.1
		6.0	145 ±10%	26.0	2.0	* 12.5
		12.0	590 ±12½%	12.6	1.0	* 6.2
		24.0	2220 ±12½%	6.6	0.53	* 3.18
CRH Min. Operate Power at 20°C 220mW	Rhodium or Tungsten	4.8	49.5 ±10%	60.0	4.2	* 25.6
		6.0	75 ±10%	50.5	3.5	* 20.8
		12.0	360 ±12½%	20.6	1.6	* 9.8
		24.0	1120 ±12½%	13.2	0.9	* 5.6
CRJ Min. Operate Power at 20°C 270mW	Rhodium or Tungsten	4.8	40 ±10%	75.7	5.4	* 38.0
		6.0	62 ±10%	61.0	4.2	* 30.0
		12.0	235 ±10%	32.2	2.2	* 16.0
		24.0	975 ±10%	15.6	1.1	* 7.7

\* Not applicable for Tungsten Reeds.

N.B. The sensitivity of the range of tungsten reed relays has been increased. These new relays can safely be used in replacement for the earlier series.



**Encapsulated reed relays (cont.)**

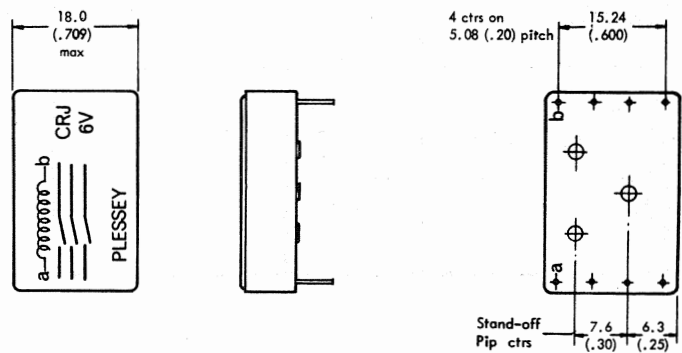
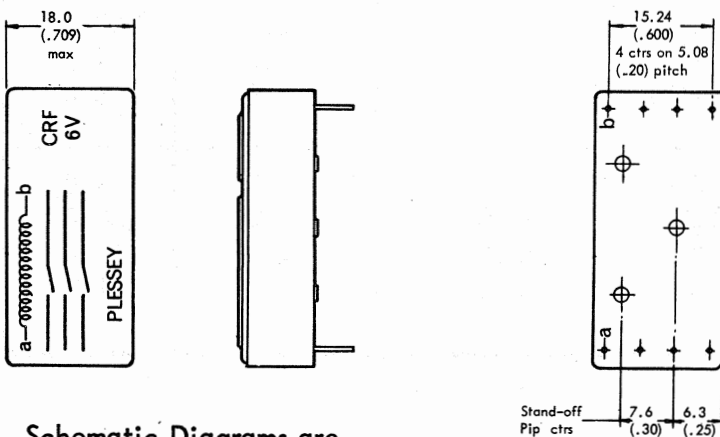
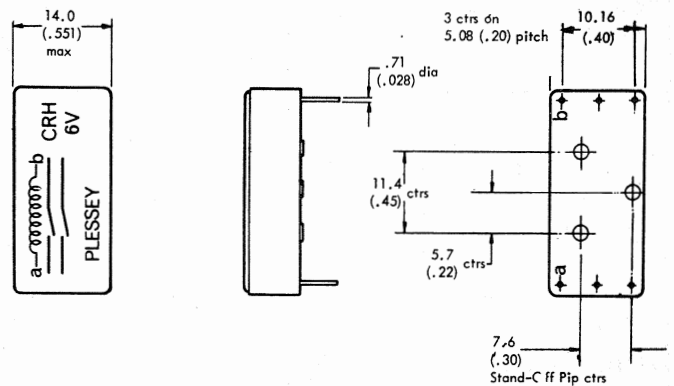
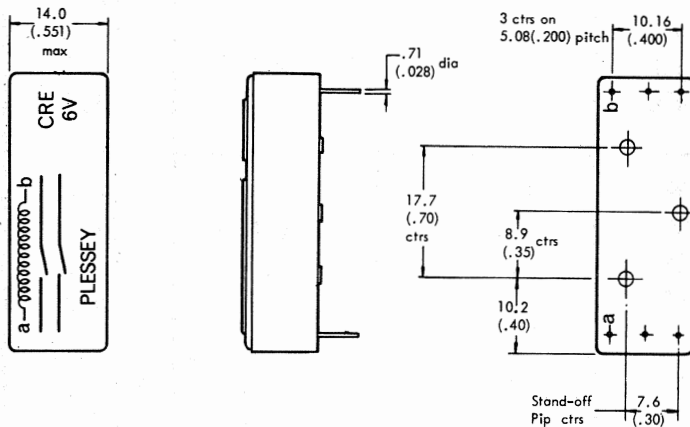
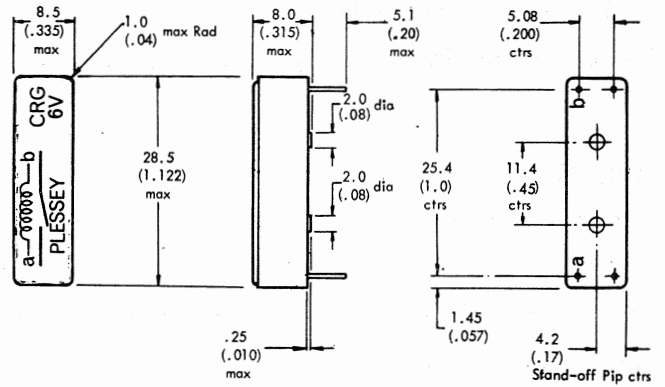
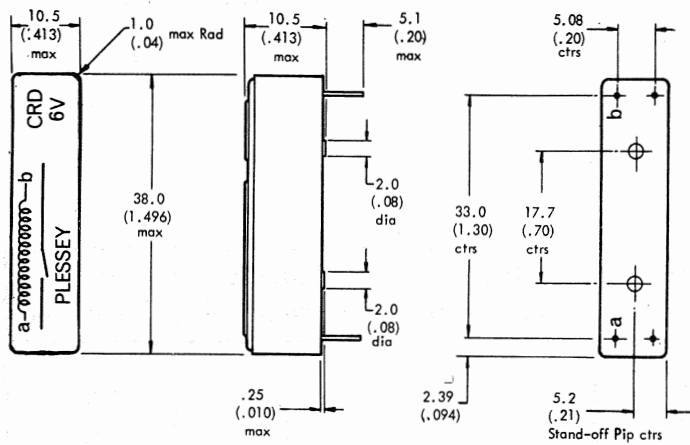

Schematic Diagrams are viewed facing termination pins

All dimensions are in millimetres (inches)



**Type IA—style SM5B**

- Fully approved to DEF5165 style SM5B.
- Hermetically sealed, with glass-to-metal seal base.
- High sensitivity.
- Single changeover, balanced armature.
- Suitable for use under conditions of acceleration, vibration and impact.

**Electrical specification**

Operate time : 12ms at 100mW power  
50ms at 20mW power

Bounce time : 5ms

Switching rate : Capable of 300 ops/minute

Nominal operate power at 15.6°C : 10mW

Maximum permissible coil dissipation : 1.0W at 70°C  
0.5W at 100°C

Maximum working voltage (coil and/or springset to frame) : 300V a.c. 50Hz

Voltage proof Between all parts not electrically connected : 1000V a.c. at 50Hz

Insulation resistance : 500MΩ (min.) at 500V d.c.

**Coil Data (DEF5165 preferred types, Style SM5B)**

Other coil resistances are available with values ranging from 0.25Ω to 14,500Ω and minimum operate currents from 200 to 0.85mA.

Nominal d.c. coil voltage	Nominal coil resistance Ω at 15.6°C	Limit circuit current (mA)
1.3	40±5%	19.5
6	720±5%	5.2
12	3100±5%	2.5
24-48	12,000+15%-10%	1.15
Constant current supply	14,000±10%	0.85

**Contact Data**

Contact arrangements available	Contact material	Contact rating (resistive load) and contact life
1c	Palladium	100mA at 300V d.c. — 10 <sup>6</sup> ops. 500mA at 50V d.c. — 10 <sup>6</sup> ops. 1A at 12V d.c. — 10 <sup>6</sup> ops.

Note : For d.c. loads an adequate spark quench must be fitted.

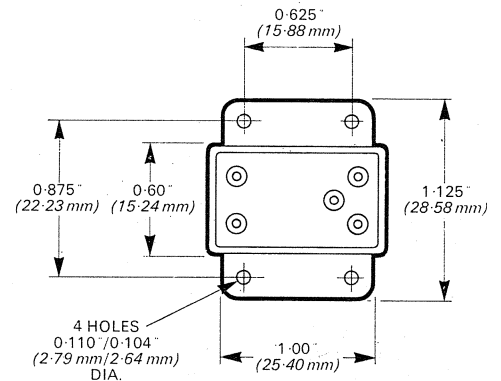
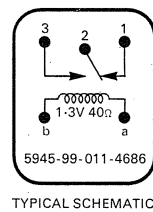
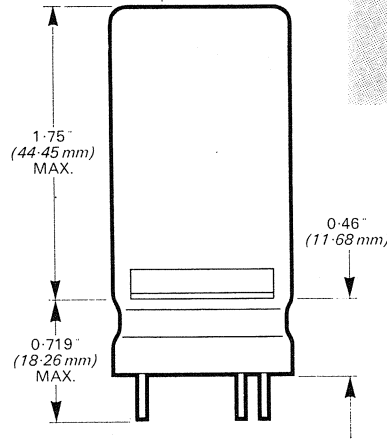
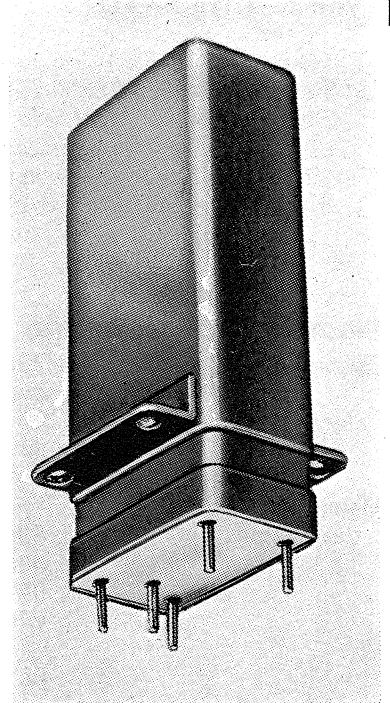



**Type 2—style SM5D**

- Hermetically sealed with glass-to-metal seal base.
- Fully approved to DEF5165 Style SM5D.
- Balanced rotary armature for excellent performance under severe shock and acceleration.
- Up to 4-pole changeover actions.
- Plug-in facilities for which a socket is available.

**Electrical specification**

Operate time : 20ms (typical—depends on contact action)

Release time : 15ms (typical—depends on contact action. Slow-release models are available with 25ms lag (min.))

Maximum permissible coil dissipation : Single winding, normal or heavy duty—3.5W at 15.6°C, 2.5W at 85°C, 2W at 100°C, double winding, normal duty—per winding, 3.5W at 15.6°C, 1.7W at 85°C, 1.5W at 100°C

Maximum working voltage (coil and/or springset to frame) : 300V a.c. at 50Hz

Voltage proof Between all parts not electrically connected : 1000V a.c. at 50Hz

Insulation resistance : 500MΩ (min.) at 500V d.c.

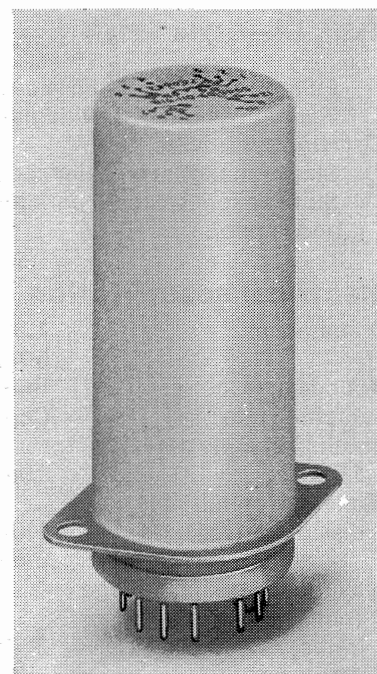

**Coil Data**

Nominal d.c. coil voltage	Nominal coil resistance Ω at 15.6°C			Limit circuit current (mA)		
	(a)	(b)	(c)	(a)	(b)	(c)
1.3	2.4	1.1	—	300	650	—
6	52	28	14.5	67	123	215
12	180	105	80	38	65	75
24	700	440	340	19.5	31	40
48	2000	1650	1000	13	18	26
Constant current supply	7500	7500	—	6	8	—

The above are preferred coil values to DEF.5165 Style SM5D. Other values are available.

- (a) Relays with 2C or 2M contacts.
- (b) Relays with 4C, 2C2K, 2B2M, MB2K, 2M2K or 2B2K contacts.
- (c) Relays with 2C normal duty contacts having double-wound coils; figures given are *per coil*.

Coil resistance tolerances are all ±5% except for 7500Ω coils which are +15%—10%.

**Contact Data**

Contact arrangements available	Contact material	Contact rating resistive load and contact life
2C, 4C, 2C2K	Platinum	100mA at 300V d.c.—10 <sup>6</sup> ops. 1A at 60V d.c.—5 × 10 <sup>5</sup> ops. 1A at 12V d.c.—10 <sup>6</sup> ops.
2M, 2B2M, MB2K, 2M2K, 2B2K	Silver	4A at 60V d.c.—2 × 10 <sup>5</sup> ops. 4A at 300V a.c.—10 <sup>5</sup> ops.

The contact arrangements given are preferred configurations in DEF.5165 Style SM5D. Other arrangements are also available.

Note: For d.c. loads an adequate spark quench must be fitted.

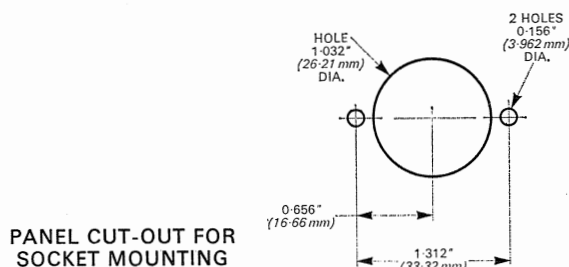
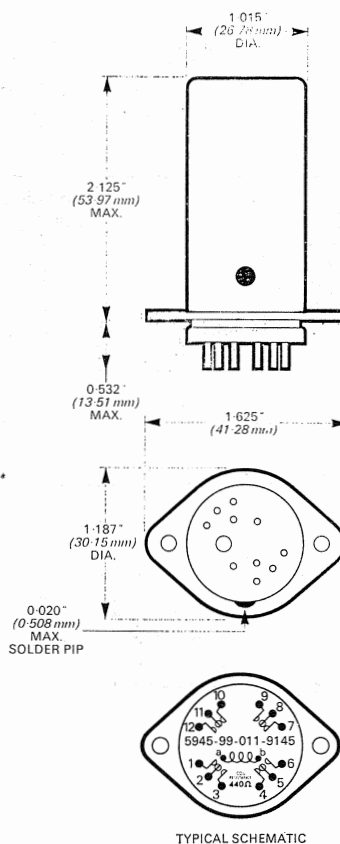



**Type CA—styles SM5A and SM4A**

- Sealed or unsealed.
- Fully approved to DEF5165, Style SM5A (sealed) and RCS166 Style SM4A (unsealed).
- Normal-, medium- and heavy-duty versions.
- Twinned contacts on normal-duty version for greater reliability.
- Heavy-duty version uses independent restoring spring and contact assembly to give high current rating in small size and protection against accidental overload.
- Plug-in facilities available for normal- and medium-duty versions.

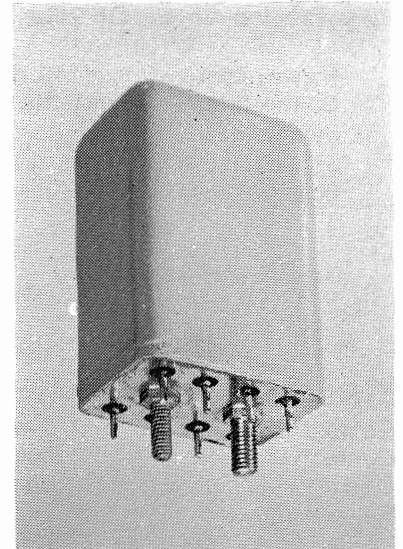

**Electrical specification**

Bounce time : 5ms max.  
 Switching rate : Capable of 500 ops/minute  
 Maximum permissible coil dissipation : 1.75W at 70°C ambient  
 1.25W at 100°C ambient  
 Maximum working voltage (coil and/or springset to frame) : 500V d.c.—300V a.c.  
 Voltage proof :  
 Between all parts not electrically connected : 1000V a.c. at 50Hz  
 Insulation resistance : 500MΩ (min.) at 500V d.c.

**Coil Data**

Nominal d.c. coil voltage	Nominal coil resistance Ω at 15.6°C	Limit circuit current (mA)
1.3	2 ± 10%	350
6	45 ± 5%	80
12	170 ± 5%	40
24	700 ± 5%	21
48	2500 ± 10%	11
72	5000 + 20% - 10%	8
96	10,000 ± 10%	6.5

**Contact Data**

Contact arrangements available	*Contact material	Contact rating (resistive load) and contact life
Normal duty 2c	Palladium	1A at 24V d.c. — 10 <sup>6</sup> ops. 100mA at 300V d.c. — 10 <sup>6</sup> ops.
Medium duty 2c	Silver-cadmium oxide	3A at 24V d.c. — 5 × 10 <sup>5</sup> ops. 5A at 24V d.c. — 10 <sup>5</sup> ops.
Heavy duty M or B	Silver-cadmium oxide	10A at 24V d.c. — 5 × 10 <sup>4</sup> ops. 10A at 300V a.c. — 5 × 10 <sup>4</sup> ops.

\*Alternative contact materials are also available.  
 Note : For d.c. loads an adequate spark quench must be fitted.

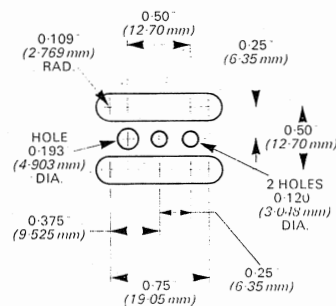
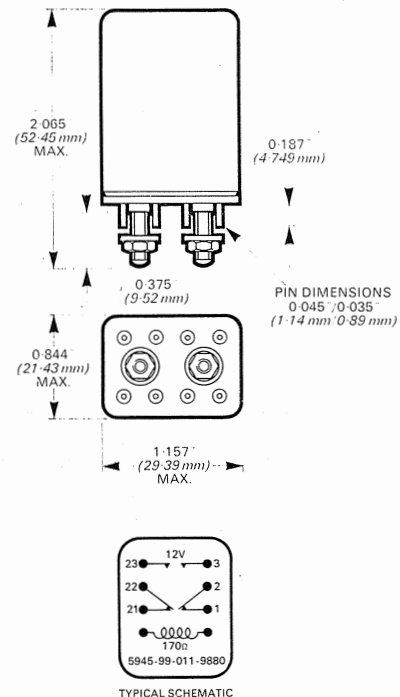

**Crystal can—type CF 2C**

- Meets requirements of MIL-R-5757.
- Connections based on 0.1 in grid spacing.
- Symmetric terminations do not require keying.
- Sockets available for plug-in version.
- Full approval DEF5165 Style SMSL.

**Electrical specification**

Contact arrangement: 2-pole changeover  
 Contact resistance: 30mΩ max. (initial)  
 Operate time: 5ms max.  
 Release time: 5ms max.  
 Insulation resistance: 1000MΩ at 500V d.c.  
 Voltage proof: 1000V RMS

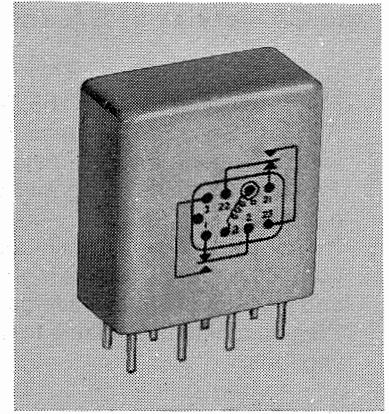

**Coil Data**

Nominal d.c. coil voltage	Nominal coil resistance Ω ±5% at 25°C	Limit circuit current (mA)
6	35	102
12	200	36
24	675	21
48	2450	12
110	9100	7.5
(Other coils available)		

**Contact Data**

Contact arrangement	Contact rating (resistive load) and contact life
2c	2A 28V d.c. – 10 <sup>5</sup> ops. 2A 115V a.c. – 10 <sup>5</sup> ops.

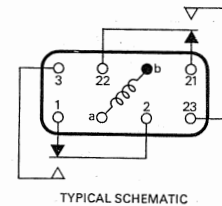
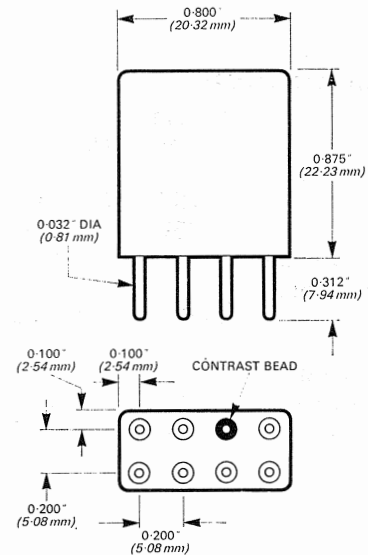

**TERMINATIONS**

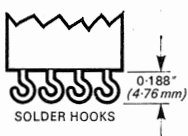

STYLE A

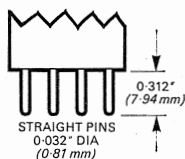

STYLE B

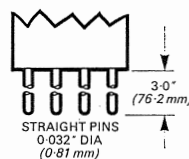

STYLE C

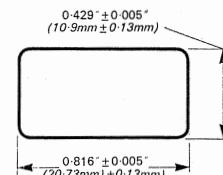

PANEL CUT-OUT FOR SOCKET

**Type CB—styles SM5M and SM4C**

- Hermetically sealed or unsealed.
- Fully approved to DEF5165 Style SM5M (sealed) or RCS166 Style SM4C (unsealed).
- Replaces obsolete Style SM5J.
- Normal-duty and heavy-duty versions.
- Twinned contacts on normal duty.
- Plug-in facilities, for which a socket is available.

**Electrical specification**

Bounce time: 10ms max.  
 Switching rate: Capable of 500 ops/minute  
 Maximum permissible coil dissipation: 1.5W at 70°C ambient  
 1.38W at 100°C ambient  
 Maximum working voltage (coil and/or springset to frame): 500V d.c.—300V a.c.  
 Voltage proof Between all parts not electrically connected: 1000V a.c. at 50Hz  
 Insulation resistance: 500MΩ (min.) at 500V d.c.

**Coil Data**

Nominal d.c. coil voltage	Nominal coil resistance Ω at 15.6°C ± 5%	Limit circuit current (mA)		
		(a)	(b)	(c)
1.3	2	310	300	398
6	40	72	85	89
12	180	32	38	39.7
24	670	18	21	21.4
48	2500	10	11	11.5
85	7600	5.3	6	—

- (a) For normal-duty contacts 1C.  
 (b) For normal-duty contacts 2C; heavy-duty 2M, MB.  
 (c) For normal-duty contacts 4C, 2C2K, 4K; heavy-duty 2B2M, 4M.

**Contact Data**

Contact arrangements available (preferred styles)	*Contact material	Contact ratings (resistive load) and contact life
Normal duty 1C, 2C, 4C, 2C2K, 4K	Palladium	100mA at 300V d.c.—10 <sup>7</sup> ops. 1A at 60V d.c.—10 <sup>6</sup> ops.
Heavy duty 2M, MB, 2B2M, 4M	Silver-cadmium oxide	4A at 60V d.c.—2 × 10 <sup>5</sup> ops. 2A at 300V d.c.—2 × 10 <sup>5</sup> ops. 4A at 300V a.c.—2 × 10 <sup>5</sup> ops.

\*Contact materials and styles shown are preferred configurations in DEF5165. Other arrangements and contact materials are available, including contacts suitable for 'dry circuit' switching.

Note: For d.c. loads an adequate spark quench must be fitted.

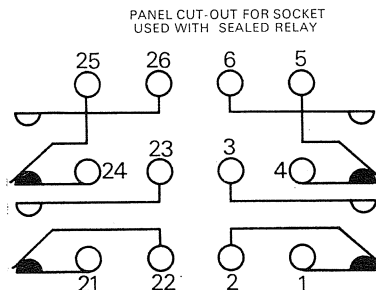
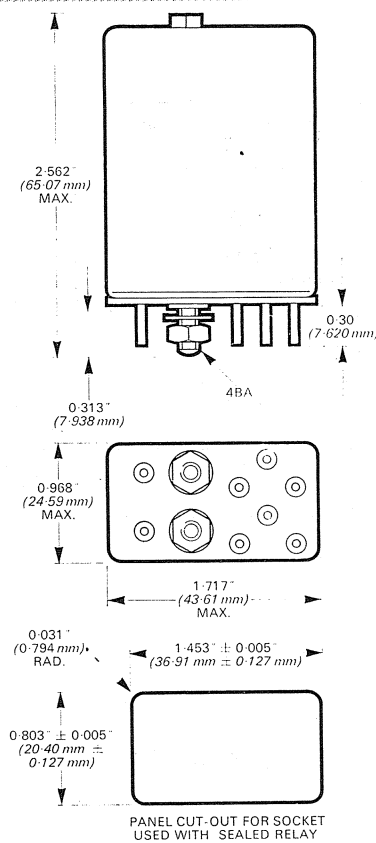
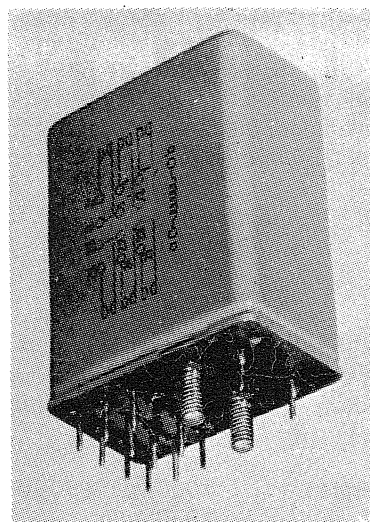



**Half-crystal can—type CN 2C**

- Meets the requirements of MIL-R-5757.
- Volume of only 0.13 in<sup>3</sup>.
- Sockets available for plug-in type.
- Full approval DEF 5156 Style SM5U.

**Electrical specification**

Contact arrangement : 2-pole changeover  
 Contact resistance : 50mΩ max. (initial)  
 Operate time : 4ms max.  
 Release time : 4ms max.  
 Insulation resistance : 1000MΩ at 500V d.c.  
 Voltage proof : 1050V d.c.  
 700V d.c. open contacts.

**Coil Data**

Nominal d.c. coil voltage	Nominal coil resistance Ω ±10% at 25°C	Limit circuit current (mA)
6	60	53
12	320	20
24	1250	10.4
48	3500	7.3
(Other coils available)		

**Contact Data**

Contact arrangement	Contact material	Contact rating (resistive load) and contact life
2c	Gold plated Silver alloy	2A at 28V d.c. — 10 <sup>5</sup> ops. 1A at 115V a.c. — 10 <sup>5</sup> ops.

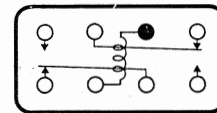
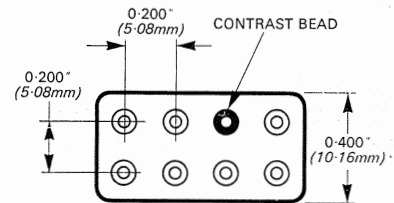
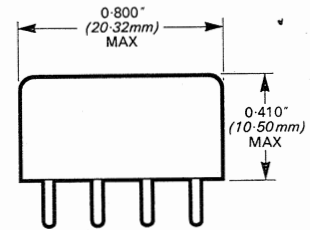
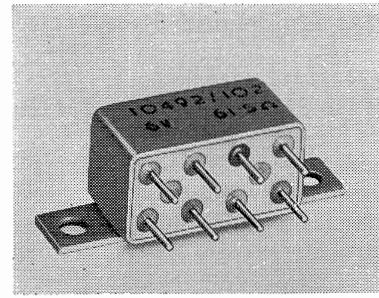

SCHEMATIC

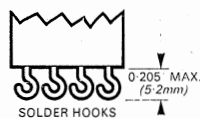

STYLE A

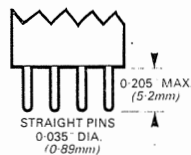

STYLE B

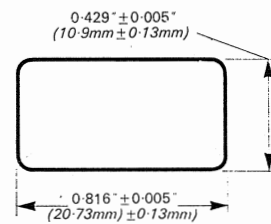

PANEL CUT-OUT FOR SOCKET



Part number, style ref. and N.A.T.O. cross reference

**Relay sealed CF2 crystal can SM5L**

Part Number	Style Ref.	N. A. T. O. Stock No. 5945-99-	Coil Res. $\Omega$	Mounting	Termination	
						507/1/02020/002
003	N137	012-2987	200			
004	N138	012-2988	675			
005	N139	012-2989	2450			
006	N140	012-2990	9100	"	"	
507/1/02092/002	SM5L-N176	012-7392	35	Side Brackets	Straight Pins 5/16"	
003	N177	012-7393	200			
004	N178	012-7394	675			
005	N179	012-7395	2450			
006	N180	012-7396	9100			"
507/1/02207/002	-	-	35	Plain Can	Plug in Straight pins 7/32"	
003	-	107-2070	200			
004	-	142.8507	675			
005	-	972-3931	2450			
006	-	-	9100			"
507/1/02196/002	-	-	35	Rear Bar	Solder Hooks	
003	-	198-1706	200			
004	-	580-5601	675			
005	-	580-5602	2450			
006	-	-	9100			"
507/1/09933/002	-	-	35	Rear Bar	Straight Pins	
003	-	-	200			
004	-	-	675			
005	-	-	2450			
006	-	-	9100			"
507/1/02099/002	-	-	35	Side Brackets	Solder Hooks	
003	-	580-1186	200			
004	-	580-1188	675			
005	-	-	2450			
006	-	-	9100			"
507/1/02096 507/2/02095 507/2/02093		Socket Retainer Relay Spring Socket Retainer				

**Relay sealed CN2 half crystal can SM5U**

Part Number	Style Ref.	N.A.T.O. Stock No. 5945-99	Coil Res. $\Omega$	Contact		Termination
				Action	Mat	
507/1/10692/116	SM5U-N1	014-2584	42	2C	Gold plated silver alloy	Straight pins
117	N2	014-2585	210			
118	N3	014-2586	830			
119	N4	014-2587	2800			
102	N5	014-3176	60			
106	N6	014-3177	320			
111	N7	014-3178	1250			
507/1/10692/114	N8	014-3179	3500			

**Relay sealed II up to 4C SM5D**

Part Number	Style Ref.	N. A. T. O. Stock No. 5945-99-	Coil Res. $\Omega$	Contact		
				Action	Duty	Mat
507/1/02518/001	SM5DN64	011-9136	2.4	2C	Norm	Plat.
002	N65	011-9137	52			
003	N66	011-9138	180			
004	N67	011-9139	700			
507/1/02518/005	SM5DN68	011-9140	2000	2C	Norm	Plat.
006	N69	011-9141	7500			
507/1/02521/001	SM5DN70	011-9142	1.1	4C	Norm	Plat.
002	N71	011-9143	28			
003	N72	011-9144	105			
004	N73	011-9145	440			
507/1/02521/011	SM5DN134	012-0306	1650	4C	Norm	Plat.
006	N75	011-9147	7500			
507/1/02525/001	SM5DN76	011-9148	1.1	2C2K	Norm	Plat.
002	N77	011-9149	28			
003	N78	011-9150	105			
004	N79	011-9151	440			

**Relay sealed IA sensitive SM5B**

Part Number	Style Ref.	N. A. T. O. Stock No. 5945-99-	Coil Res. $\Omega$	Contact		
				Action	Duty	Mat
507/1/02440/001	SM5BN28	011-4685	14000	IC	Normal	Palladium
002	N170	014-2765	300	"	"	"
003	N169	014-2764	140	"	"	"
004	N166	014-2761	8.8	"	"	"
007	N171	014-2766	800	"	"	"
009	N174	014-2769	5000	"	"	"
010	N175	014.2770	7000	"	"	"
013	N29	011-4686	40	"	"	"
014	N30	011-4687	720	"	"	"
015	N52	011-4688	3100	"	"	"
016	N53	011-4689	12000	"	"	"
019	N172	014-2767	1200	"	"	"
022	N173	014-2768	4000	"	"	"
023	N167	014-2762	20	"	"	"
026	N165	014-2760	0.25	"	"	"
027	N168	014-2763	90	"	"	"
507/1/02498/014	-	-	720	"	"	"

Part Number	Style Ref.	N. A. T. O. Stock No. 5945-99-	Coil Res. $\Omega$	Contact		
				Action	Duty	Mat
507/1/02525/007	SM5DN135	012-0307	1650	2C2K	Norm	Plat.
006	N81	011-9153	7500			
507/1/02520/002	SM5DN82	011-9154	14.5+14.5	2C	Norm	Plat.
003	N83	011-9155	80+80			
004	N84	011-9156	340+340			
005	N85	011-9157	1000+1000			
507/1/02529/001	SM5DH40	011-9158	2.4			
002	H41	011-9159	52			
003	H42	011-9160	180			
004	H43	011-9161	700			
507/1/02529/005	SM5DH44	011-9162	2000	2M	Heavy	Elk.
006	H45	011-9163	7500			
507/1/02531/001	SM5DH52	011-9170	1.1	2B2M	Heavy	Elk.
002	H53	011-9171	28			
003	H53	011-9172	105			
004	H55	011-9173	440			



Part number, style ref. and N.A.T.O. cross reference

Relay sealed II up to 4C SM5D (cont.)

Part Number	Style Ref.	N. A. T. O. Stock No. 5945-99-	Coil Res. Ω	Contact		
				Action	Duty	Mat.
507/1/02531/008 006	SM5DH81 H57	012-0308 011-9175	1650 7500	2B2M	Heavy	Elk.
507/1/02535/001 002 003 004	SM5DH58 H59 H60 H61	011-9176 011-9177 011-9178 011-9179	1.1 28 105 440	MB2K	Heavy	Elk.
507/1/02535/007 006	SM5DH82 H63	012-0309 011-9181	1650 7500	MB2K	Heavy	Elk.
507/1/02536/001 002 003 004	SM5DH64 H65 H66 H67	011-9182 011-9183 011-9184 011-9185	1.1 28 105 440	2M2K	Heavy	Elk.
507/1/02536/007 006	SM5DH83 H69	012-0310 011-9187	1650 7500	2M2K	Heavy	Elk.
507/1/02537/001 002 003 004	SM5DH70 H71 H72 H73	011-9188 011-9189 011-9190 011-9191	1.1 28 105 440	2B2K	Heavy	Elk.
507/1/02537/007 006	SM5DH84 H75	012-0311 011-9193	1650 7500	2B2K	Heavy	Elk.
507/1/02517/009 507/1/02517/010 507/1/02530/007 008		519-8103 519-8104 519-8105 519-8106	1000 7500 52 700	1C 1C 1M1B "	Norm Norm Heavy "	Plat. Plat. Elk. "

Relay sealed CB up to 4C SM5M

Part Number	Style Ref.	N.A.T.O. Stock No 5945-99-	Coil Res. Ω	Contact		
				Action	Duty	Mat.
507/1/02326/097 098 099 100	SM5M-N141 N142 N143 N144	012-3862 012-3863 012-3864 012-3865	2 40 180 670	1C	Normal	Pal'dm
507/1/02326/101 102	N145 N146	012-3866 012-3867	2500 7600	1C	Normal	Pal'dm
507/1/02326/016 017 018 019	N147 N148 N149 N150	012-3868 012-3869 012-3870 012-3871	2 40 180 670	2C	Normal	Pal'dm
507/1/02326/020 021	N151 N152	012-3872 012-3873	2500 7600	2C	Normal	Pal'dm
507/1/02326/001 002 003 004	N153 N154 N155 N156	012-3874 012-3875 012-3876 012-3877	2 40 180 670	4C	Normal	Pal'dm
507/1/02326/005	N157	012-3878	2500	4C	Normal	Pal'dm
507/1/02326/033 034 035 036	N158 N159 N160 N161	012-3879 012-3880 012-3881 012-3882	2 40 180 670	2K2C	Normal	Pal'dm
507/1/02326/037	N162	012-3883	2500	2K2C	Normal	Pal'dm
507/1/02326/040 041	SM5M-N163 N164	012-3884 012-3885	180 670	4K	Normal	Pal'dm
507/1/02291/001 002 003 004	H 85 H 86 H 87 H 88	012-3886 012-3887 012-3888 012-3889	2 40 180 670	2M	Heavy	Silver
507/1/02291/005	H 89	012-3890	2500	2M	Heavy	Silver
507/1/02291/012 013 014 015	H 90 H 91 H 92 H 93	012-3891 012-3892 012-3893 012-3894	2 40 180 670	MB	Heavy	Silver
507/1/02291/016	H 94	012-3895	2500	MB	Heavy	Silver
507/1/02291/006 007 008 009	H 95 H 96 H 97 H 98	012-3896 012-3897 012-3898 012-3899	2 40 180 670	2B2M	Heavy	Silver
507/1/02291/010	H 99	012-3968	2500	2B2M	Heavy	Silver
507/1/02291/019 020	H100 H101	012-3971 012-3972	180 670	4M	Heavy	Silver

Relay sealed CA up to 2C SM5A

Part Number	Style Ref.	N. A. T. O. Stock No. 5945-99-	Coil Res. Ω	Contact		
				Action	Duty	Mat.
507/1/02284/031 032 033 034 035	SM5A-N93 N94 N95 N96 N97	011-9878 011-9879 011-9880 011-9881 011-9882	2 45 170 700 2500	2C	Normal	Pall.
507/1/02882/001 002 003 004 005	SM5A-M1 M2 M3 M4 M5	053-0470 053-0471 053-0472 053-0473 053-0474	2 45 170 700 2500	2C	Medium	Cad. Silver
507/1/02881/011 012 013 014 015	SM5A-H76 H77 H78 H79 H80	011-9883 011-9884 011-9885 011-9886 011-9887	2 45 170 700 2500	1M	Heavy	Cad. Silver



Part number, style ref. and N.A.T.O. cross reference

Relay unsealed CA up to 2C SM4A

Part Number	Style Ref.	N. A. T. O. Stock No. 5945-99-	Coil Res. $\Omega$	Contact		
				Action	Duty	Mat.
507/1/02285/001	SM4A-N2	053-0455	2	2C	Normal	Pall.
002	N3	053-0456	45			
003	N4	053-0457	170			
004	N5	053-0458	700			
005	N6	053-0459	2500			

Relay reed contact CRD to CRJ

Type	Part Number	Finish	Contact	Volt
CRD	507/1/10960/101	Gold	1 Make	6
	102			12
	103			24
	105			4.8
CRE	507/1/10961/101	Gold	2 Make	6
	102			12
	103			24
CRF	507/1/10962/101	Gold	3 Make	6
	102			12
	103			24
CRG	507/1/10963/101	Gold/Rhodium	1 Make	6
	102			12
	103			24
	105			4.8
CRH	507/1/10964/101	Gold/Rhodium	2 Make	6
	102			12
	103			24
	105			4.8
CRJ	507/1/10965/101	Gold/Rhodium	3 Make	6
	102			12
	103			24
	105			4.8
CRJ	507/1/10965/201	Tungsten	3 Make	6
	202			12
	203			24
	205			4.8

Relay unsealed CB up to 4C SM4C

Part Number	Style Ref.	N.A.T.O. Stock No. 5945-99	Coil Res. $\Omega$	Contact		
				Action	Duty	Mat.
507/1/02292/054	SM4C-N44	012-3973	2	1C	Normal	Pall
055	N45	012-3974	40			
056	N46	012-3975	180			
057	N47	012-3976	670			
058	N48	012-3977	2500			
059	N49	012-3978	7600			
507/1/02292/017	N50	012-3979	2	2C	Normal	Pall
018	N51	012-3980	40			
019	N52	012-3981	180			
020	N53	012-3982	670			
021	N54	012-3983	2500			
022	N55	012-3984	7600			
507/1/02292/001	N56	012-3985	2	4C	Normal	Pall
002	N57	012-3986	40			
003	N58	012-3987	180			
004	N59	012-3988	670			
005	N60	012-3989	2500			
507/1/02292/033	N61	012-3990	2			
034	N62	012-3991	40			
035	N63	012-3992	180			
036	N64	012-3993	670			
037	N65	012-3994	2500			
507/1/02292/040	N66	012-3995	180	4K	Normal	Pall
041	N67	012-3996	670			

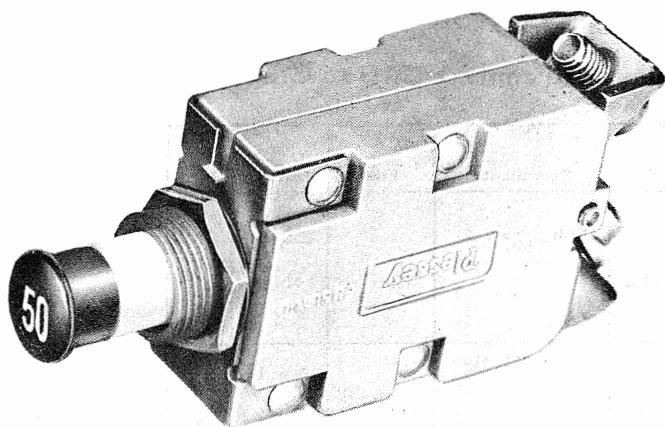

### Series 700

The series 700 circuit breaker is of single-pole double-break construction with overload sensing by a series bi-metal strip. Manual operation is by push-pull button on which the unit rating is boldly marked. Eight ratings are available between 5 and 50 amps. The breaker is trip-free at any overload value which will trip it normally, and no pull-out motion is required before resetting can be accomplished.

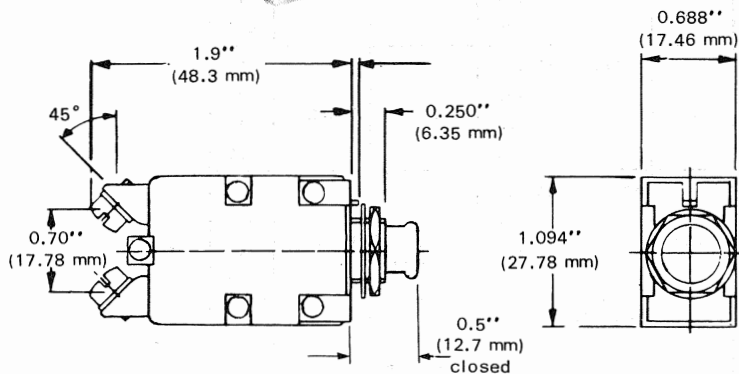

Vibration . . . . .	B.S.G. 100 Grade 2
Acceleration . . . . .	B.S.G. 100 Grade 1
D.C. rupture capacity	1000A or 3000A prospective current
A.C. rupture capacity	750A prospective current
Temperature . . . . .	-65 to 70°C
Weight . . . . .	45g (1.58 oz)

### Part numbers (8 ratings)

#### 1000A D.C. rupture

- 7CZ-106664/5B
- 7CZ-106664/7B
- 7CZ-106664/10B
- 7CZ-106664/15B

#### 3000A D.C. rupture

- 7CZ-106664/20B
- 7CZ-106664/25B
- 7CZ-106664/35B
- 7CZ-106664/50B



## Pneumatic Time-delay Relays

P.T.D.s are devices for delaying the start or finish of the operation of an electrical circuit relative to the energization or de-energization of the control circuit. Typically, they are used extensively in process and control automation, motor control in cranes and lifts, and load distribution in multiple circuits.

This range of time-delay relays incorporates a pneumatic switch assembly. This is normally operated by a solenoid, and units with this method of operation are mounted on a base-plate which can then be installed in the required

position. For service in hazardous areas, units can be supplied enclosed in an aluminium case.

Among options available are a choice of timing ranges, switch ratings and operating voltages; solenoids can be d.c. or a.c. operated; and units with an additional instantaneous or time-delay switch are available.

All Pye Ether P.T.D.s are built from high quality components. Certain types included in the range are NATO and Admiralty approved, and the appropriate approval numbers can be given on request.

## Timer Selection Chart (This chart is for general reference, please consult the relevant specifications as all the variations cannot be shown)

TIME RANGE	TYPE	REPEAT ACCURACY	OPERATION	INPUT VOLTAGE	SWITCH CAPACITY	MOUNTING	TYPICAL APPLICATION
1/6sec – 3min (1/6sec – 20min Special)	480D	±10%	Delay on Energ.	5V – 280V d.c.	5A at 230V a.c. 3A at 440V a.c.	CHASSIS (case mounting option)	Motor control systems for lifts and cranes Elimination of transients Sequencing of electrical contactors.
	490D		Delay on De-Energ.				
	485D		Delay on Energ. + Inst c/o Switch				
	495D		Delay on De-Energ. + Inst c/o Switch	5A at 24V d.c.			
	491D		Delay on Energ. and on De-Energ.		1A at 110V d.c.		
	500D		Delay on Energ.	6V – 750V a.c.			
	510D		Delay on De-energ.				
	525D		Delay on Energ. + Inst c/o Switch				
	525D/1		Delay on De-Energ. + Inst c/o Switch				
	521D		Delay on Energ. and on De-Energ				
0.2 – 2.5min (0.2 – 5min Special)	500D/1		PNEUMATIC UNIT ONLY			CHASSIS	As above but greater switching capacity.
	1100C		PNEUMATIC UNIT ONLY			CHASSIS	
					20A at 440V a.c. 5A at 600V a.c.	CHASSIS	
	1101C	Delay on Energ.	12V – 600V a.c.	2HP at 230/ 460V a.c. 1 HP at 115V a.c.			
	1103C	Delay on De-Energ.					
	1105C	Delay on Energ. and on De-Energ.					
	1107C	Delay on Energ. + Inst c/o Switch					
	1109C	Delay on De-Energ. + Inst c/o Switch					
	1102C	Delay on Energ.	6V – 330V d.c.	5A at 24V d.c. 0.5A at 110V d.c. 0.375A at 250V d.c.			
	1104C	Delay on De-Energ.					
1106C	Delay on Energ. and on De-Energ.						
1108C	Delay on Energ. + Inst c/o Switch						
1110C	Delay on De-Energ. + Inst c/o Switch						

### Series 480D to 525D

The mode of operation of this series can be changed at will from delay on energization to delay on de-energization by reversing the solenoid on the base-plate. Rate of expansion of the pneumatic bellows, which are enclosed in a steel case, is set by adjustment of an air bleed screw.

Basic features include solenoid operation from either AC or DC, delay times variable between 1/6 second and 20 minutes, switching capacity of 5A.

### Specification Delay Period

1/6 second to 3 minutes standard.  
1/6 second to 20 minutes special.

### Repeatability Switch

±10% of setting, standard units.  
Single pole, change-over, snap action double break-and-make. Contacts fine silver. Ratings 230V AC or 24V DC at 5A; 3A at 440V AC; 1A at 110V DC; 0.5A at 230V DC. All non-inductive.

## Solenoid assembly

**Coil voltages.** 6V to 750V 50/60Hz. 5V to 280V D.C. standard voltages: A.C.: 115V, 240V and 440V D.C.: 24V, 30V, 50V and 110V. All coils operate at  $\pm 10\%$  nominal voltage.

**Power consumption.** 42VA (10W) A.C., 20W D.C.

**Construction.** Coils can be vacuum impregnated to order.

**Insulation.** 2,000V A.C. coil-to-frame. 2,000V A.C. contacts-to-frame.

## Standard Models

D.C. type    A.C. type    Operation

480D	500D	Delay on energization
490D	510D	Delay on de-energization
485D	525D	Delay on energization plus an additional instantaneous change over switch
495D	525D/1	Delay on de-energization plus an additional instantaneous change over switch
491D	521D	Double-acting unit, delay on both energization and de-energization

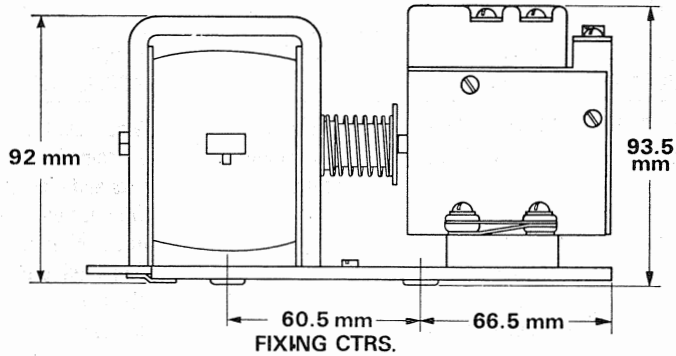

DC Type 480D. Type 490D as 480Db ut with solenoid reversed.

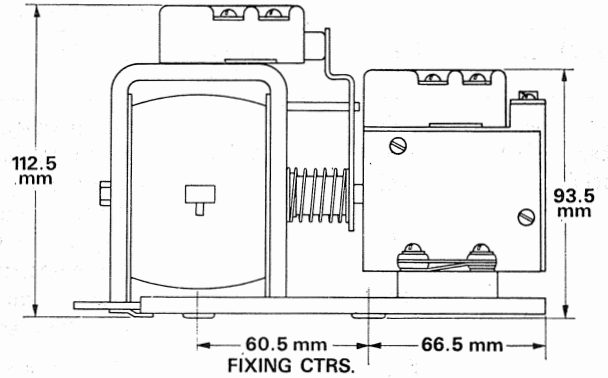

DC Type 485 D. Type 495D as 485D but with solenoid reversed.

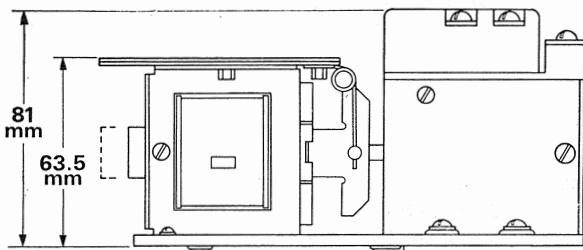

AC Type 500D. Type 510D as 500D but with solenoid reversed.

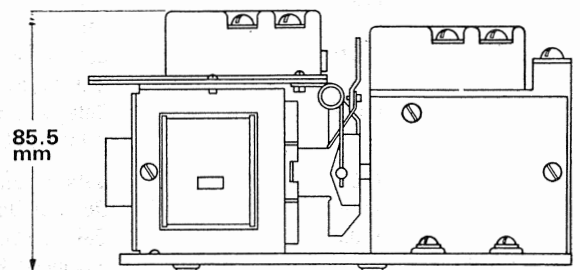

AC Type 525D. Type 525D/1 as 525D but with solenoid reversed.

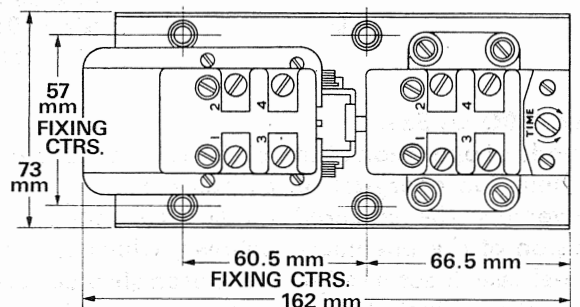
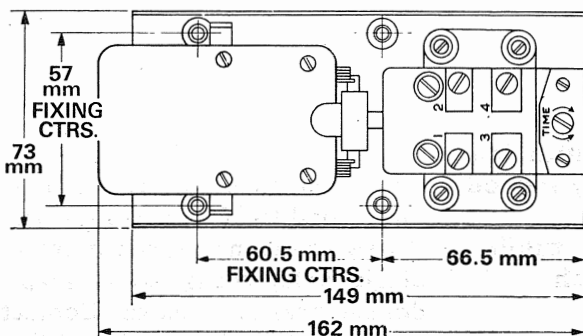

## Series 1100C Relays

These units are basically the same as the 480D to 525D types but are more compact and have a higher switching capacity. As with the aforementioned types, the mode of operation may be changed from delay on energize to delay on de-energize by simple reversal of the solenoid on the base plate.

### Technical specification

#### Pneumatic switch assembly

**Time-delay period.** 1/5th second to 2.5 minutes: standard. 1/5th second to 5 minutes: special.

**Repeatability.**  $\pm 10\%$  of setting: standard units.

**Switch type.** Single-pole change-over (CSA approval LR13897-3).

**Switch contacts.** Fine silver.

**Switch contact ratings.** 20A at 460V AC. 5A at 600V AC or 24V DC 1500W at 230/460V AC motorload.

550W at 115V AC motor load. 0.5A at 125V DC. 0.375A at 250V DC.

**Switch operation.** Snap-action double break-and-make.

#### Solenoid assembly

**Coil voltages.** 12V to 600V 50/60Hz. 6V to 330V DC.

All coils operate at  $\pm 10\%$  of nominal voltage. Standard voltages: AC 115V, 240V and 440V, 50 or 60Hz. DC 24V, 30V, 50V and 110V.

**Power consumption.** 30VA AC. 15W DC.

**Construction.** Coils can be vacuum impregnated to order.

**Insulation.** 2,000V AC coil-to-frame. 2,000V AC contacts-to-frame.

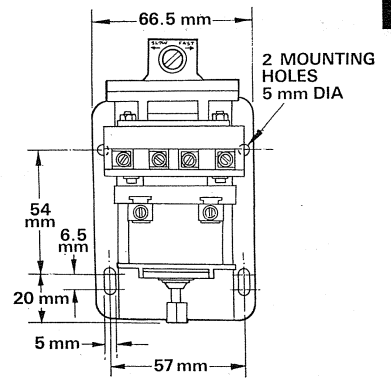
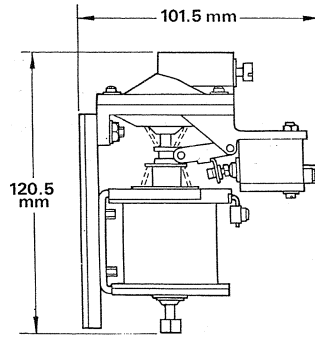

Types 1101C to 1104C

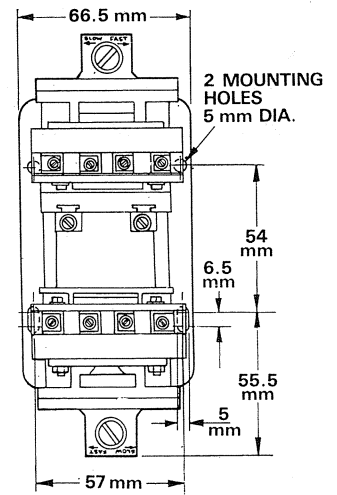
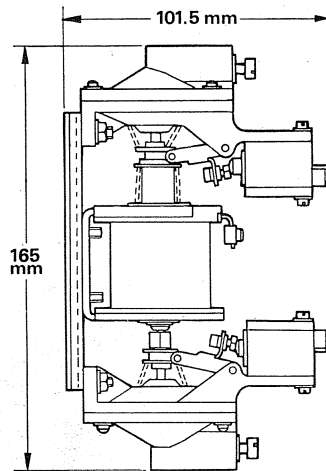

Types 1105C and 1106C

### Standard Models

AC type	DC type	Operation
1101C	1102C	Delay on energization
1103C	1104C	Delay on de-energization
1105C	1106C	Double-acting unit, delay on both energization and de-energization
1107C	1108C	Delay on energization plus an additional instantaneous change-over switch
1109C	1110C	Delay on de-energization plus an additional instantaneous change-over switch

The pneumatic switch assembly is available separately: Type 1100C.

### Ordering information

1. Type number
2. Coil voltage and frequency
3. Vacuum impregnation, if required
4. Type of terminals:  
For 4BA screw terminals (standard) add suffix /A for quick connect spade type (6.35 mm  $\times$  0.8 mm)
5. Add suffix /C for switch terminal cover
6. Add suffix /L for extended time-delay period and state delay time required

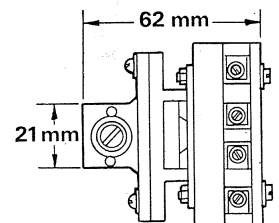
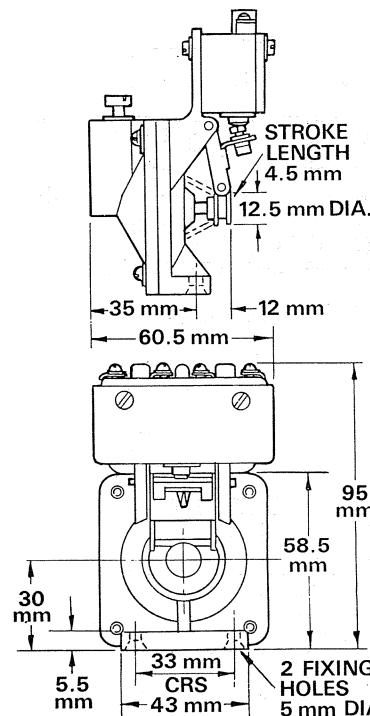

Type 1100C Time delay Unit

Types and coil data

Type	*Coil voltage (V DC)	Pull-in voltage (V at 25°C)	Drop-out voltage (V at 25°C)	Max V at 40°C	*Coil resistance (V at 25°C)	Inductance (H)	
						Armature open	Armature closed
NF2- 6V	6	4.2	0.6	10.5	137	0.093	0.094
NF2-12V	12	8.4	1.2	21	500	0.338	0.344
NF2-24V	24	16.8	2.4	42	2000	1.29	1.31

Type	*Coil voltage (V DC)	Pull-in voltage (V at 25°C)	Drop-out voltage (V at 25°C)	Max V at 40°C	*Coil resistance (V at 25°C)	Inductance (H)	
						Armature open	Armature closed
NF4- 6V	6	4.2	0.6	8.5	90	0.07	0.071
NF4-12V	12	8.4	1.2	17	330	0.22	0.23
NF4-24V	24	16.8	2.4	34	1200	0.77	0.79

Notes: \*Less than 1,000Ω: ±10%. More than 1,000Ω: ±15%

Maximum allowable voltage at 40°C is twice nominal

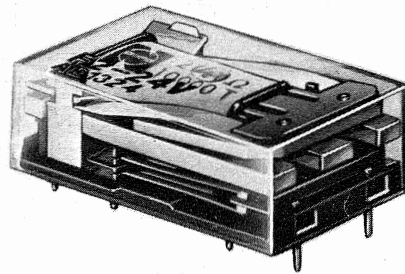

Dimensions

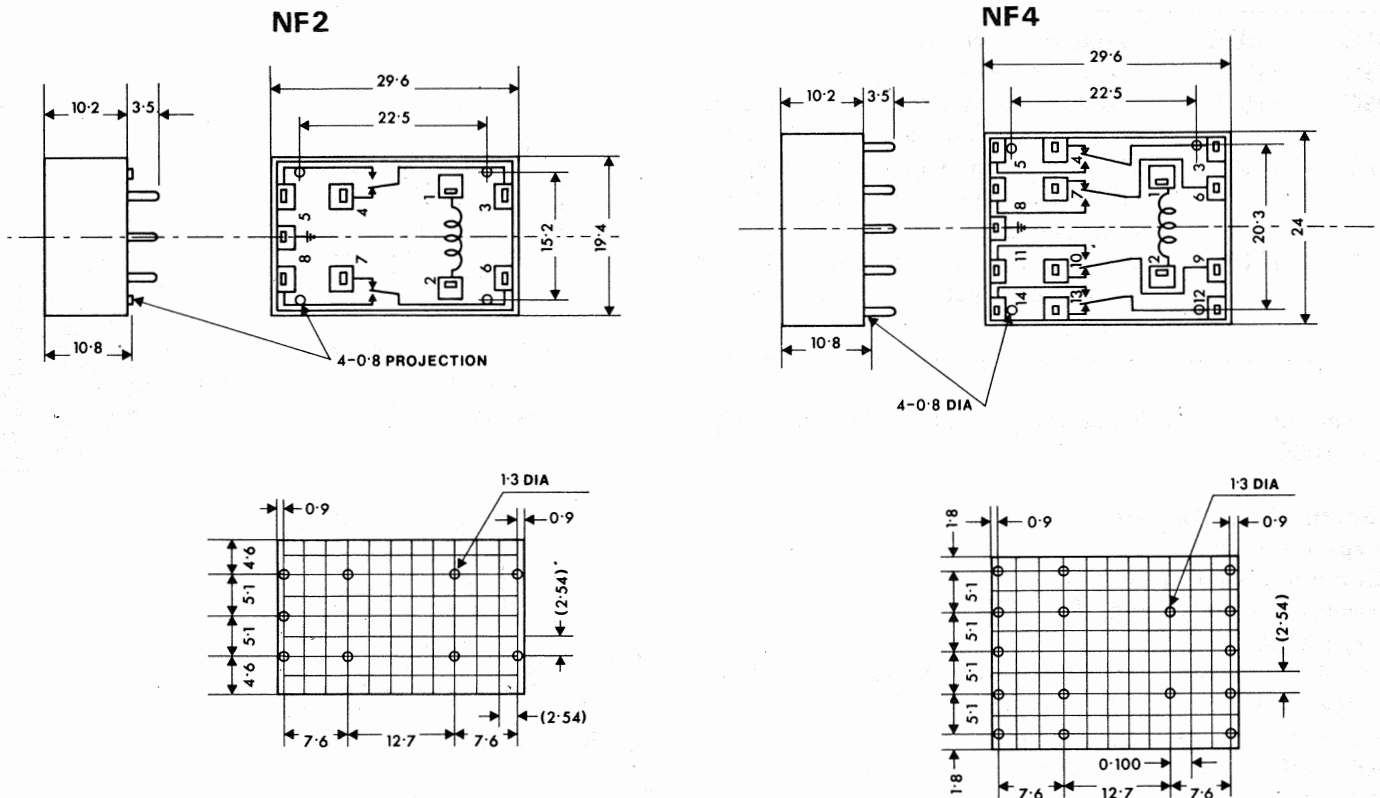

all dimensions are in millimetres

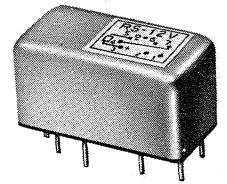

## High speed series

### Operation

R relays are polarised – there are two basic types:

**SINGLE SIDE STABLE SPDT CONTACTS**, to be used like a non-polarised relay. Polarity must be correct, the relay will not operate if the coil supply is reversed.

**BISTABLE (LATCHING) SPDT CONTACTS**, to be operated by either a single coil or twin coil. An impulse of 0.5ms (minimum) operates the contact into the corresponding position.

Each type is available as 'RH' Hermetically sealed, or 'RS' Magnetically shielded and Hermetically sealed.

### Types

#### Power types

Single side stable and 1 coil		Bistable (Latching) and 1 coil		Bistable (Latching) and 2 coils	
Hermetically sealed	Shielded and hermetically sealed	Hermetically sealed	Shielded and hermetically sealed	Hermetically sealed	Shielded and hermetically sealed
RH- 5V	RS- 5V				
RH- 6V	RS- 6V	RHL- 5V	RSL- 5V	RHL2- 5V	RSL2- 5V
RH-12V	RS-12V	RHL- 6V	RSL- 6V	RHL2- 6V	RSL2- 6V
RH-24V	RS-24V	RHL-12V	RSL-12V	RHL2-12V	RSL2-12V
		RHL-24V	RSL-24V	RHL2-24V	RSL2-24V

### Coil data

#### 1 Single side stable (RHD, RSD, RH, RS)

Nominal coil voltage	Pull-in voltage	Drop-out voltage	Max. allowable voltage	Coil resistance	Nominal operating power	Inductance
DC (V)	DC (V) (25°C)	DC (V) (25°C)	DC (V)	(±10%Ω) (25°C)	(mW)	(H)
3	2.0	0.3	6	37	243	0.013
5	3.5	0.5	13	170	147	0.050
6	4.3	0.6	14	220	164	0.075
12	8.4	1.2	28	890	162	0.3
24	16	2.4	42	2,000	288	0.66
28	19	2.8	65	4,500	174	1.9
35	24	3.5	75	6,000	204	2.4
42	28	4.2	85	8,000	221	2.7
60	40	6.0	110	12,000	300	3.9

Max. allowable operating power; 1 watt at 25°C

Changing ratio of pull-in voltage by temperature; refer to Fig.5

#### 2 1 coil Bistable (Latching)(RHL, RSL)

Nominal coil voltage	Pull-in voltage	Max. allowable voltage	Coil resistance	Nominal operating power	Inductance
DC (V)	DC (V) (±25°C)	DC (V)	(±10%Ω) (25°C)	(mW)	(H)
1.5	1.0	4.6	24	94	0.01
3	2.0	9	90	100	0.037
5	3.5	18.5	340	74	0.12
6	4.3	20	450	80	0.16
12	7.5	30	1,500	96	0.66
24	16	75	6,000	96	2.4
35	19	85	8,000	153	2.7
42	23	110	12,000	147	3.9

Max. allowable operating power; 1 watt at 25°C

Changing ratio of pull-in voltage by temperature; refer to Fig.6

**High speed series**

**Coil data (cont.)**

③ 2 coil Bistable (latching) (RHL2D, RSL2D, RHL2, RSL2)

Nominal coil voltage	Pull-in voltage	Max. allowable voltage	Coil resistance ( $\pm 10\% \Omega$ ) (25°C)		Nominal operating power	Inductance
			Coil I	Coil II		
DC (V)	DC (V) ( $\pm 25^\circ\text{C}$ )	DC (V)			(mW)	(H)
1.5	1.0	3.2	12	12	188	0.0025
3	2.0	6.3	45	45	200	0.009
5	3.5	13.0	170	170	147	0.024
6	4.3	14.0	225	225	160	0.04
12	7.5	26.0	650	650	230	0.14
24	17.0	50.0	2,700	2,700	213	0.35
35	19.0	60.0	3,700	3,700	331	0.6
42	23.0	75.0	5,500	5,500	321	0.8

Max. allowable operating power; 1 watt at 25°C  
 Changing ratio of pull-in voltage by temperature; refer to Fig.6

**Dimensions**

