



BOSE®

FreeSpace® System Controller

General Description

The Bose® FreeSpace® system controller can be used with Bose business music products. It features:

- Active equalization for FreeSpace Model 8, Model 25, Model 32, and Bose 102® loudspeakers
- Two channels of non-equalized line output which can be used to interconnect with systems like the Bose FreeSpace One and FreeSpace 6 business music systems
- Three separate input channels for microphone, Channel A, and Channel B
- Opti-voice circuitry for paging capability
- Rack mount enclosure allows simple installation

Technical Specifications

The rear panel has screw-type quick connect terminal block connectors for the following inputs and outputs:

Page Input Sensitivity
At microphone: 5mV nominal

At line: 100mV nominal

Page Input Impedance
Microphone: 3kΩ (balanced)

Line: 200kΩ (balanced)

Channel A and Channel B
Input Sensitivity

At 300mV switch position:
200mV nominal

Input Impedance: 15kΩ (balanced)

At 2V switch position: 1V nominal

Input Impedance: 2kΩ (balanced)

Line Output (Unequalized)

Output level: 6V RMS max

Output impedance: 600Ω (balanced)

Frequency range: 40Hz – 20kHz

Paging: Channel A and Channel B
individually switchable

Model 8 Output (Equalized)

Output level: 6V RMS max

Output impedance: 600Ω (balanced)

Frequency range: 80Hz – 16kHz

Paging: Channel A page always on;
Channel B page switch selectable

Model 25/Model 32/Bose 102®
Output (Equalized)

Output level: 6V RMS max

Output impedance: 600Ω (balanced)

Frequency range: 80Hz – 16kHz

Paging: Channel A page always on;
Channel B page switch selectable

LED Indicators

2 LED indicators on front panel signal
power on and page in use

LED indicator on rear panel for adjusting
page volume

Opti-voice® Paging Circuitry

Voice band-pass equalization for good
speech intelligibility

AGC circuit for automatic compensation
of varying input levels

Gradual return of music to original level
after page

Rear Panel Switches

Gain control switches

Channel A and Channel B: 300mV – 2V

Page: Line and microphone

Bass cut switch: cut 6dB at 90Hz

Line output switch: turn page on or off
for line A and B

Model 8/Model 32 output switches:
turn page on/off for Channel B

Audio Ground Switch: set GND to
connect audio ground and chassis
ground. Set OPEN to disconnect audio
ground from chassis ground

Power Requirements

100V, 120V, 220-240V ~ 50/60Hz

Power Consumption

7 Watts

Regulatory Compliance

Complies with UL-813, UL-1711,
CSA-C22.2, No. 1- M1990, EN-60065
and MITI

Dimensions

1.63" (H) x 19" (W) x 10" (D)

(4.13 (H) x 48.26 (W) x 25.4 (D) cm)

Weight

5.5 lb (2.5 kg)



FreeSpace®
BUSINESS MUSIC SYSTEMS

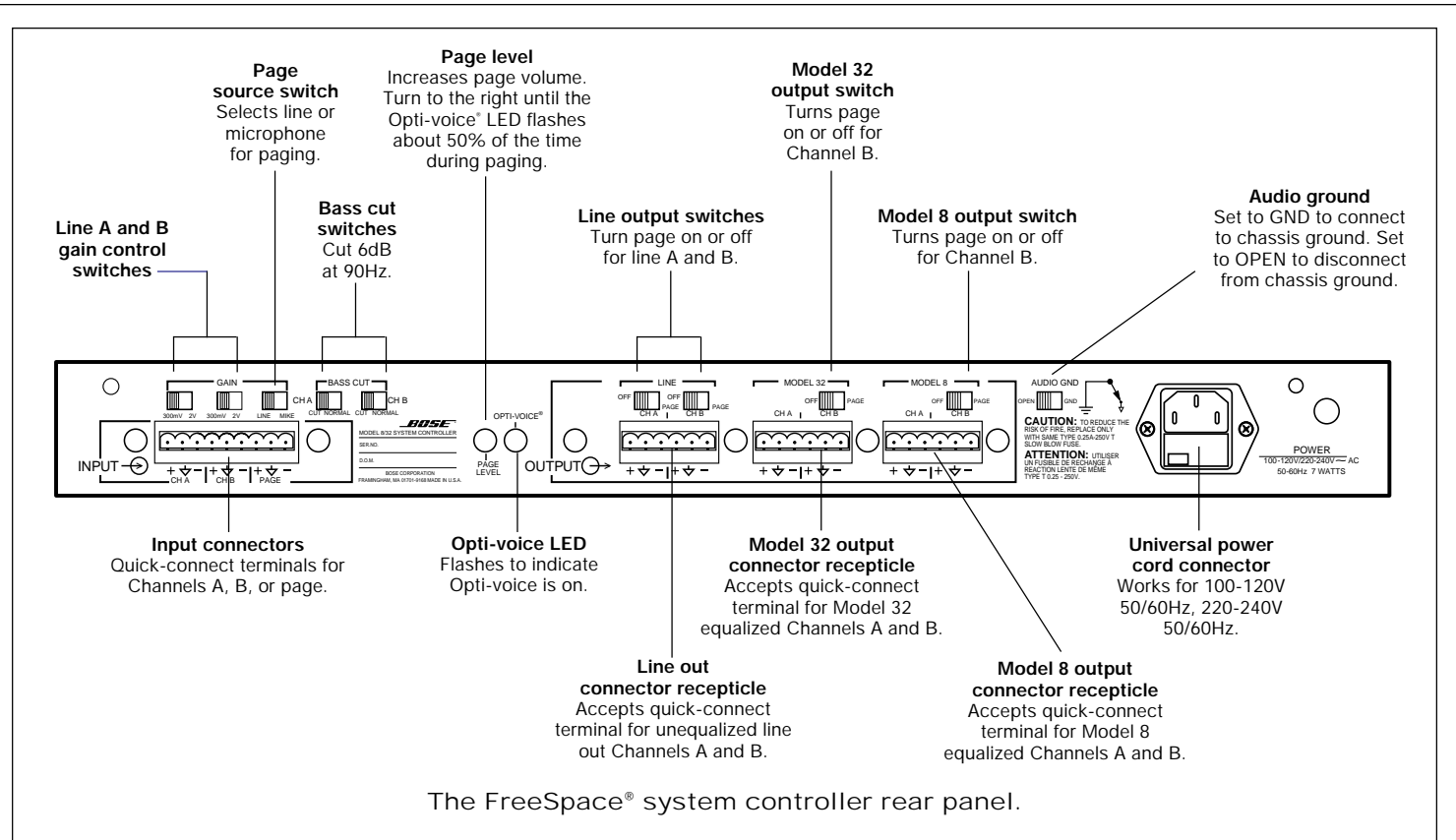

System Configuration

Detailed installation and operating instructions for the system controller are provided in the *Bose® FreeSpace® System Controller Installer's Guide*.

Engineers' and Architects' Specifications

The system controller provides active electronic equalization for 8 Watt, 25 Watt, and 32 Watt ceiling loudspeakers. It also provides non-equalized line output which can be used to power music systems. The system controller is to be connected before the input(s) of the system power amplifier(s). The controller shall be rack-mountable in a single space of a standard 19" equipment rack.

The rear panel of the system controller shall use screw-type quick-connect terminal blocks for all input and output connectors. The controller shall have input for microphone, Channel A, and Channel B. Either page or line input shall be selectable for the paging channel.

The sensitivity of the page input shall be 5mV (nominal) at the microphone and 100mV (nominal) at line. The impedance of the page input shall be 3kΩ, balanced, for the microphone and 200kΩ, balanced, for line input. Channel A and Channel B input shall have a sensitivity of 200mV nominal at the 300mV switch position and input sensitivity of 1V nominal at the 2V switch position. The input impedance of Channel A and Channel B shall be 15kΩ (balanced) at the 300mV position and 2kΩ (balanced) at the 2V position.

The unequalized line output shall have maximum output level of 6V RMS. The output impedance shall be 600Ω balanced. The frequency response of the line output shall be 40Hz to 20kHz. Paging shall be individually switchable for Channel A and Channel B. The equalized output to the loudspeakers shall have a maximum output level of 6V RMS. The output impedance shall be 600Ω balanced. The frequency response shall be 80Hz to 16kHz for the loudspeakers. Channel A always has paging on; Channel B paging shall be switchable.

The front panel of the system controller shall have a power switch and two LED indicators which signal power on and page on. A LED indicator on the rear panel of the system controller shall indicate when the page volume has reached its optimum level. Bass cut switches for Channel A and Channel B, for reducing acoustic feedback to the microphone, shall be located on the rear panel. The rear panel shall also have output switches for line output which turns page on or off for line A and B, as well as output switches for both loudspeakers which turn page on or off for Channel B. An open-to-chassis ground switch shall also be located on the rear panel.

The system controller can operate with 100V, 120V, and 220-240V voltages at 50/60Hz. The system controller shall consume 7 Watts of power. The unit shall be 1.63" (4.13 cm) high, 19" (48.26 cm) wide and 10" (25.4 cm) deep. It shall weigh 5.5 lb (2.5 kg).

The system controller shall be the Bose® FreeSpace® system controller.

Warranty Information

The Bose® FreeSpace® system controller is covered by a 5-year, transferable limited warranty.

Bose Corporation, Professional Products Division, The Mountain, Framingham, MA 01701-9168 USA
 TEL (508) 879-7330 FAX (508) 872-6541
 Bose products are distributed worldwide.
 Product features and specifications subject to change without notice. Bose is a registered trademark of Bose Corporation.
 © 1994 Bose Corporation. Covered by patent rights issued and/or pending. JN95501 PN180546

