



Service Manual

LINEAR MOTOR ARM STEREO TURNTABLE

PL-L1000

 **PIONEER®**

MODEL PL-L1000 COMES IN THREE VERSIONS DISTINGUISHED AS FOLLOWS:

Type	Voltage	Remarks
HET	220V and 240V (Switchable)	Europe model (without cartridge)
HBT	220V and 240V (Switchable)	United Kingdom model (without cartridge)
S/G	110V, 120V, 220V, 240V and (Switchable)	U.S. Military model (with cartridge)

CONTENTS

1. SPECIFICATIONS	3	7. ADJUSTMENTS	
2. PANEL FACILITIES	4	7.1 D.D. Motor Operating Point Adjustment	25
3. DISASSEMBLY		7.2 Auto Lead-in Timing Adjustment	25
3.1 Panel	6	7.3 End Sensor Sensitivity Adjustment	25
3.2 D.D. Motor	7	7.4 End Timer Adjustment	25
3.3 Tonearm	7	7.5 Tracking Sensor Zero Point Adjustment	26
3.4 CdS Detector and Lamp	8	7.6 Tracking Sensor Gain Adjustment	26
4. PARTS LOCATIONS	9	7.7 Lead-in and Return Speed Adjustment ...	26
5. BLOCK DIAGRAM	11	8. TIMING CHART	27
5.1 Tonearm Control Stage	13	9. TROUBLESHOOTING	
5.2 End Detector Stage	13	9.1 Circuit Block	29
5.3 Arm Elevation Control Stage	13	9.2 Mechanism Block	38
5.4 Size Selector Stage	13	10. EXPLODED VIEWS	
5.5 Repeat Control Stage	13	10.1 Exterior	45
5.6 Lowering Position Detector, Plunger Control Stage and Descent Signal Generator	13	10.2 Tonearm	48
5.7 Display Stage and Plunger Driver	13	10.3 EV Mechanism	50
5.8 Manual Drive Stage	14	10.4 Bottom Plate	51
5.9 Tracking Sensor Stage and Tonearm Driver Stage	14	11. PACKING	54
5.10 D.D. Motor Control Stage and D.D. Motor Stop Control	14	12. SCHEMATIC DIAGRAM (HET, HBT model) ..	55
6. CIRCUIT DESCRIPTIONS		13. P.C. BOARD CONNECTION DIAGRAM (HET, HBT model)	58
6.1 Full Auto Logic	15	14. PARTS LIST OF P.C. BOARD ASSEMBLY (HET, HBT model)	61
6.2 Tonearm Drive	21	15. SCHEMATIC DIAGRAM (S/G model)	63
		16. P.C. BOARD CONNECTION DIAGRAM (S/G model)	66
		17. PARTS LIST OF P.C. BOARD ASSEMBLY (S/G model)	69

1. SPECIFICATIONS

Motor and Turntable

Drive System	Direct-drive
Motor	Quartz PLL Hall motor
Turntable Platter	310mm diam. aluminum alloy die-cast
Inertial Mass	330kg-cm ² (including platter mat mass)
Speeds	33-1/3 and 45rpm
Wow and Flutter	Less than *0.013% (WRMS) 0.025% (WRMS) 0.035% (DIN)

Values marked with an "*" designate the wow and flutter for motor, and do not include the cartridge or tonearm load.

Signal-to-Noise Ratio	More than 78dB (DIN-B) (with Pioneer cartridge model PC-600)
-----------------------	---

Rotational Characteristics

Build-up Time	Within 90° rotation at 33-1/3rpm
Speed Deviation	Less than 0.002%
Speed vs. Load Characteristics	Stable up to 220 grams drag load
Speed Drift	Less than 0.00008%/h at 33-1/3rpm Less than 0.00003%/degree temp. change at 33-1/3rpm

Tonearm

Type	Linear Motor Direct-drive Static-balance type, Linear-tracking arm
Effective Arm Length	190mm
Overhang	0mm
Usable Cartridge Weight	.4g (min.) to 24g (max.)
Arm Height Adjust Range	±3mm
Headshell weight	10.5g

Subfunctions

- Auto lead-in
- Auto-return
- Auto cut
- Quick repeat
- Quick play
- Quick stop
- Stylus pressure direct-readout counterweight
- Arm height adjusting device
- Cueing device
- Free stop hinges

Semiconductors

ICs	22
Transistors	17
Diodes	16
Hall Elements	3
LED	14
Photo Transistors	5
CdS	1

Miscellaneous

Power Requirements	
HET, HBT models	AC220/240V ~ (switchable) 50, 60Hz
S/G model	AC110/120/220/240V ~ (switchable) 50, 60Hz
Power Consumption	35W
Dimensions	494(W) x 154(H) x 456(D)mm 19-7/16(W) x 6-1/16(H) x 17-15/16(D) in.
Weight	12kg/26lb 8oz
Accessories	
EP Adapter	1
Screwdriver	1
Overhang gauge	1
Level	1
Cleaning cloth	1
Cartridge mounting parts (HET, HBT models only)	
Cartridge mounting screws	6
Cartridge mounting nuts	2
Cartridge mounting washers	2
Cartridge PC-600 (S/G model only)	1
Operating instructions (French and German furnished on models for HET)	1

NOTE:

Specifications and design subject to possible modification without notice, due to improvements.

2. PANEL FACILITIES

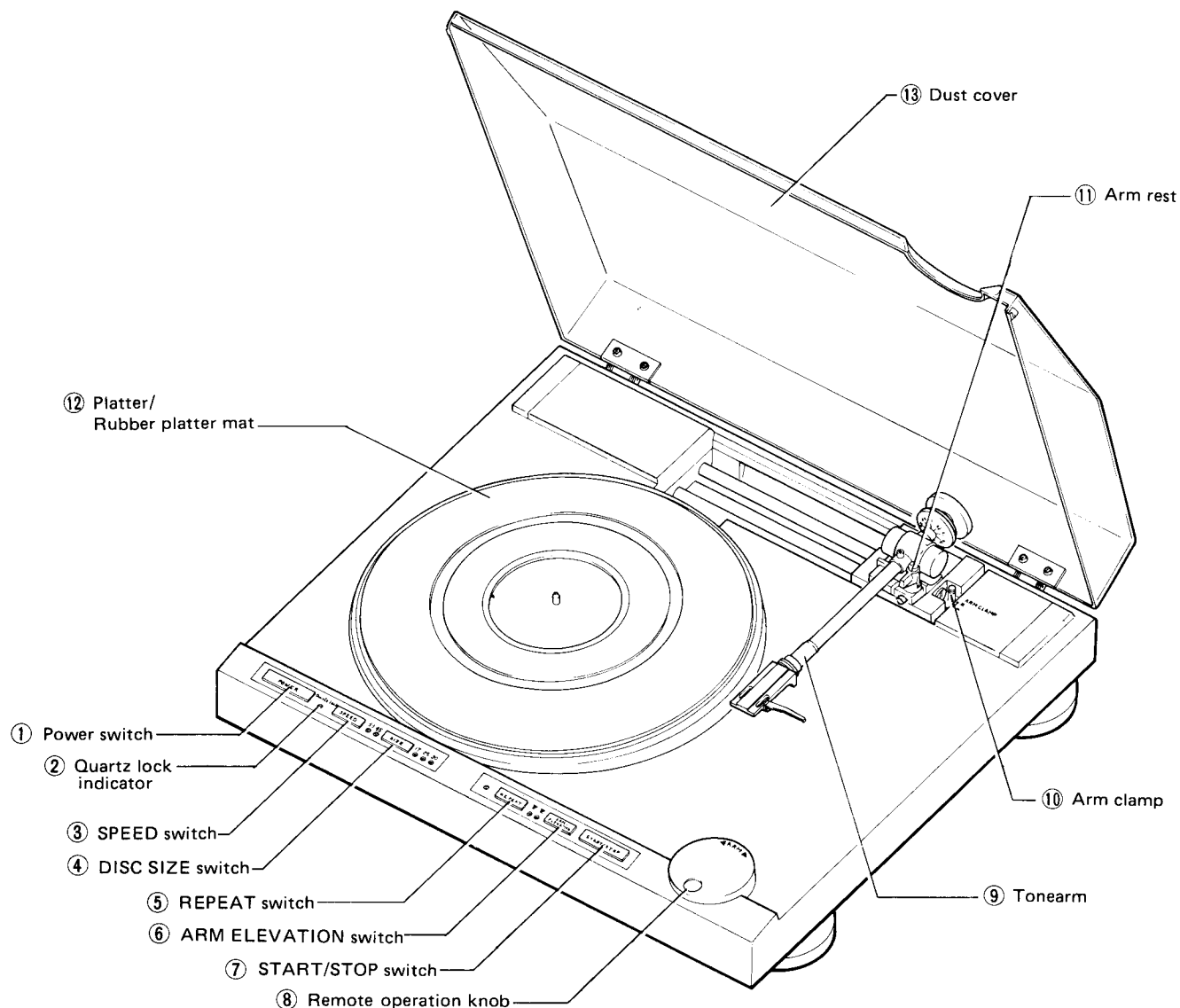

① POWER SWITCH

Used to switch on and off the power to the turntable. Power is supplied when the switch is depressed (ON). The SPEED switch indicator (33) comes on. The power is switched off when the POWER switch is released.

NOTES:

- The platter does not rotate when the tonearm is positioned at the far right even if the switch is depressed and the power supplied.
- With each push, this switch alternates between the ON and OFF positions.
- Keep the POWER switch at the OFF position when you are not using the turntable.

② QUARTZ LOCK INDICATOR

This indicator illuminates when the platter is revolving at the specified rate of 33-1/3 or 45 rpm.

NOTE:

If the platter speed varies, such as when the speed switch is changed from one position to another or when you press momentarily on the platter, the indicator will go off. As the platter revolution returns to the specified speed, the indicator will illuminate again.

③ SPEED SWITCH

- 33 Set the switch to this position when playing a 33-1/3 rpm record such as an LP. When it is depressed, the 33 indicator lights up, and the platter rotates at a speed of 33-1/3 rpm.
- 45 Set the switch to this position when playing a 45 rpm record like an EP. When it is depressed, the 45 indicator lights up, and the platter rotates at a speed of 45 rpm.

④ DISC SIZE SWITCH

Selects the switch that corresponds to the size of the record you want to hear for auto play operation.

- 12"30 . . . For 30cm records
- 10"25 . . . For 25cm records
- 7"17 . . . For 17cm records

- Used to select the record size when depressed. For instance, when the 30cm indicator lights up, depress the switch for the 25cm position, and depress it again for the 17cm position. Depressing the switch once more sets it to the 30cm position.
- When the power switch is turned ON, the turntable will always be set for records with a diameter of 30cm and the corresponding light will come on.

NOTE:

This switch will not work if depressed when the tonearm is moving (auto lead-in, auto-return, auto cut).

⑤ REPEAT SWITCH

Press this switch for repeat play. When pressed the indicator will light up, and the record will be played again (refer to page 12 for further details on repeat play). Press this switch again to release it. The indicator will go off and the repeat play function will be released.

NOTE:

This switch will not work if depressed when the tonearm is moving (auto-return, auto cut).

⑥ ARM ELEVATION SWITCH

Use this switch to interrupt play temporarily or to perform manual play.

When the DOWN position is depressed the tonearm will descend and when the UP position is depressed the tonearm will rise. These two operations will be performed alternately every time the switch is pressed.

NOTES:

- When the POWER switch is set to ON, the tonearm will start in the UP position.
- This switch will not work if depressed when the tonearm is moving (auto lead-in, auto-return, auto cut).
- When the switch is at UP, the auto-return cancelling mechanism is actuated and so there will be no auto-return.

⑦ START/STOP SWITCH

Press this switch for auto play. The platter will start to rotate, the tonearm will automatically move over to the edge of the record and play will begin (auto lead-in).

If this switch is pressed during play, the tonearm will automatically return to the arm clamp position, the platter will stop rotating and play will be suspended (auto cut).

NOTE:

This switch will not work if depressed when the tonearm is moving (auto lead-in).

⑧ REMOTE OPERATION KNOB

Used when moving the tonearm by remote control. Rotate counterclockwise to move the tonearm to the left. Rotate clockwise to move the tonearm to the right.

NOTE:

When the arm elevation switch is at DOWN or auto lead-in, auto cut and auto-return, the tonearm does not move even when the remote operation is released and the knob rotated.

⑨ TONEARM

The tonearm function is to apply the correct tracking force to the cartridge, maintain this value precisely and allow the stylus to trace the record grooves accurately.

The tonearm can be operated manually with your hand or remotely with the remote operation knob. It is coupled to the motor switch and when it moves across to the record, the platter rotates and it stops when the tonearm is returned to the arm clamp position.

NOTE:

When the POWER switch is at OFF, the tonearm cannot be moved by either manual or remote operation. If it is forced at the OFF position, this may result in damage so always remember to set the POWER switch to ON when moving it.

⑩ ARM CLAMP

Used to secure the tonearm.

To secure the tonearm, move it to the right and then push down on the clamp. When you do not intend to use the turntable, secure the tonearm in this way. The tonearm is released when the clamp is raised.

⑪ ARM REST

This secures the tonearm pipe. When playing a record, rotate the arm rest counterclockwise and release the clamp. When not playing a record, set the arm elevation switch to UP (∇) and then rotate the arm rest clockwise and secure the pipe.

NOTE:

When the arm elevation switch is at DOWN (∇), the tonearm pipe cannot be secured. Make sure this switch is set to the UP (∇) position.

⑫ PLATTER/RUBBER PLATTER MAT

When the tonearm is moved and power is supplied to the turntable, the platter will start rotating at the set rotation speed. The rubber platter mat stabilizes the records and also absorbs external vibration.

⑬ DUST COVER

Keep this closed unless operating the controls or tonearm, or changing records. This serves to keep dust off of the records during record play. When fully opened and pulled straight up, this dust cover can be removed from the cabinet.

3. DISASSEMBLY

3.1 PANEL

1. Remove the 4 insulator mounting screws.
2. Remove the top cover.
3. Shift the tonearm across to the center.
4. Lift the panel up, and disconnect the 3 connectors from the printed circuit board below.

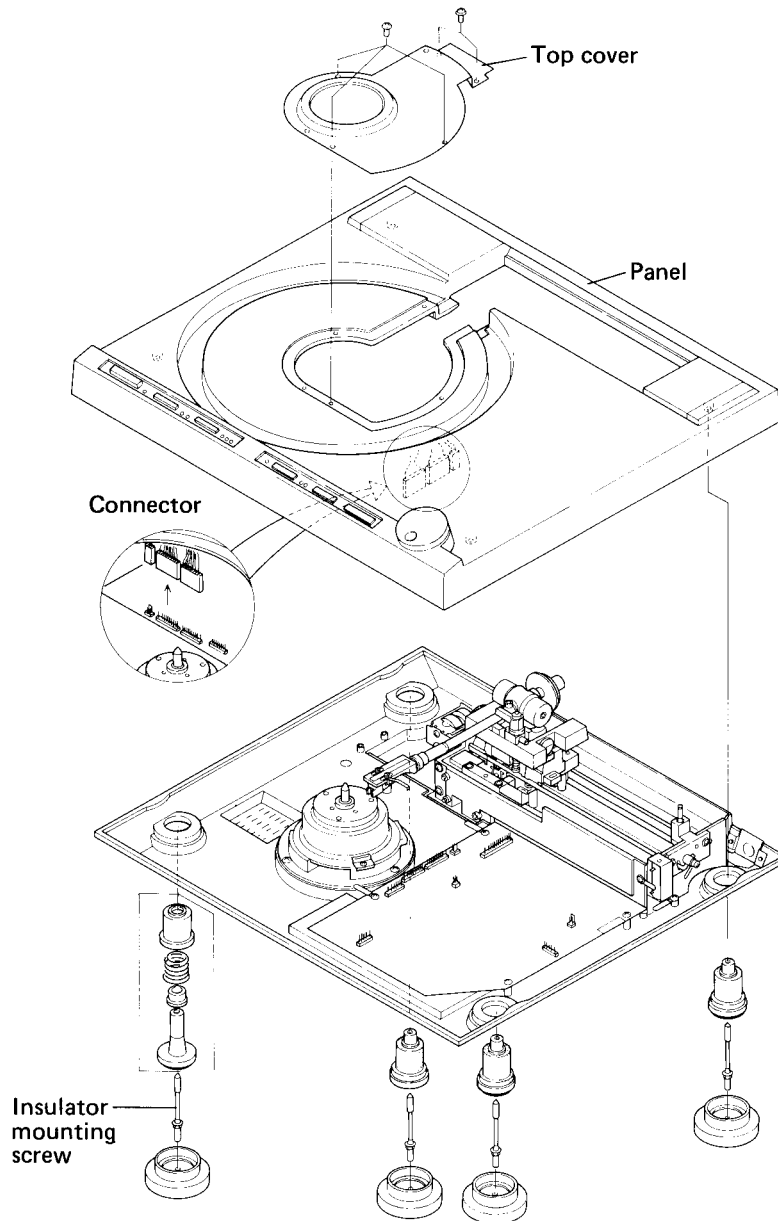

Fig. 3-1

3.2 D.D MOTOR

1. Remove the 3 D.D motor securing screws.
2. Disconnect the D.D motor connector.

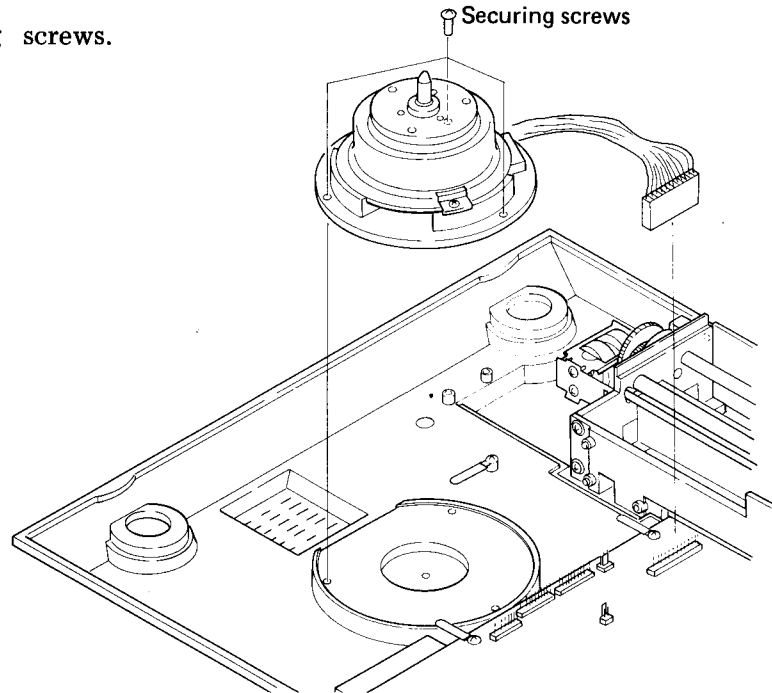

Fig. 3-2

3.3 TONEARM

1. Remove the plate pressing against the tone-arm output cable.
2. Remove the coil & rail ass'y.
3. Disconnect the ground lead connected to the front rail from P.C.B.
4. Remove the E-type washers and screw holding the gear and rail of the elevation mechanism. The front rail may then be removed by pulling

- out towards the right.
5. The other rail may also be removed by pulling out to the right after loosening the securing screw.
6. The tonearm may be removed once both rails have been pulled across to the right by at least 15cm.

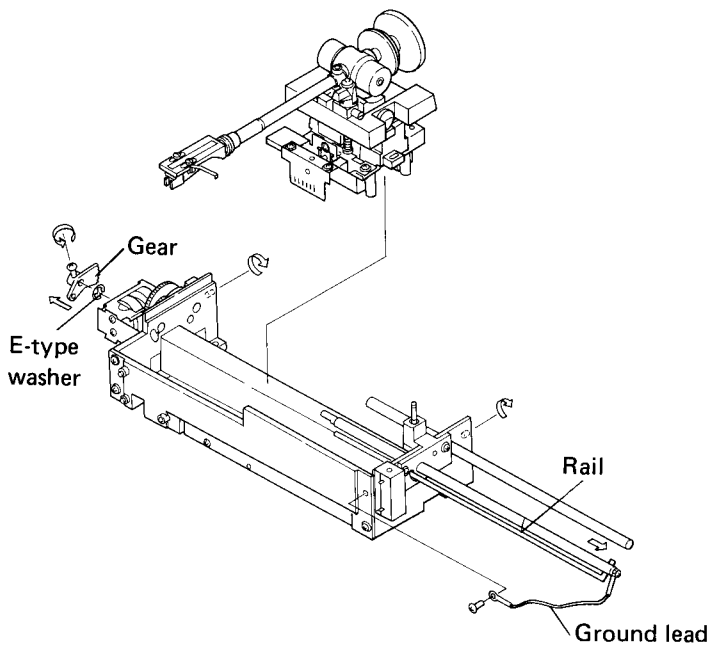

Fig. 3-3

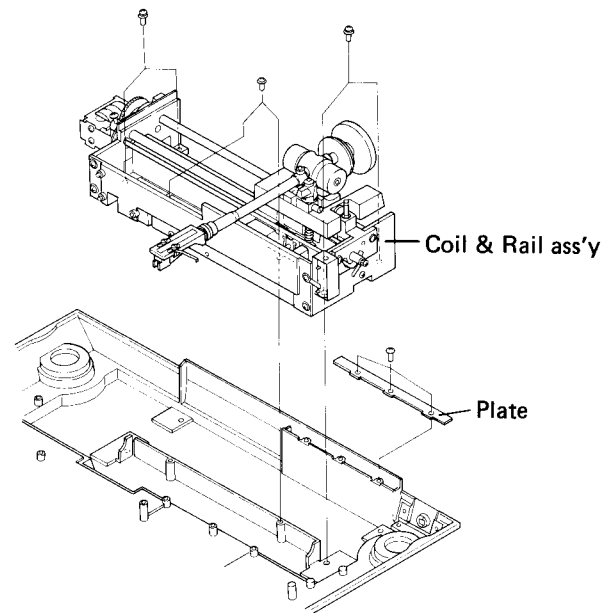

Fig. 3-4

3.4 CdS DETECTOR AND LAMP

1. After removing the tonearm, remove the CdS detector and lamp in the way indicated in Fig. 3-5.
2. Remove the shutter before removing the spacer securing the CdS detector.

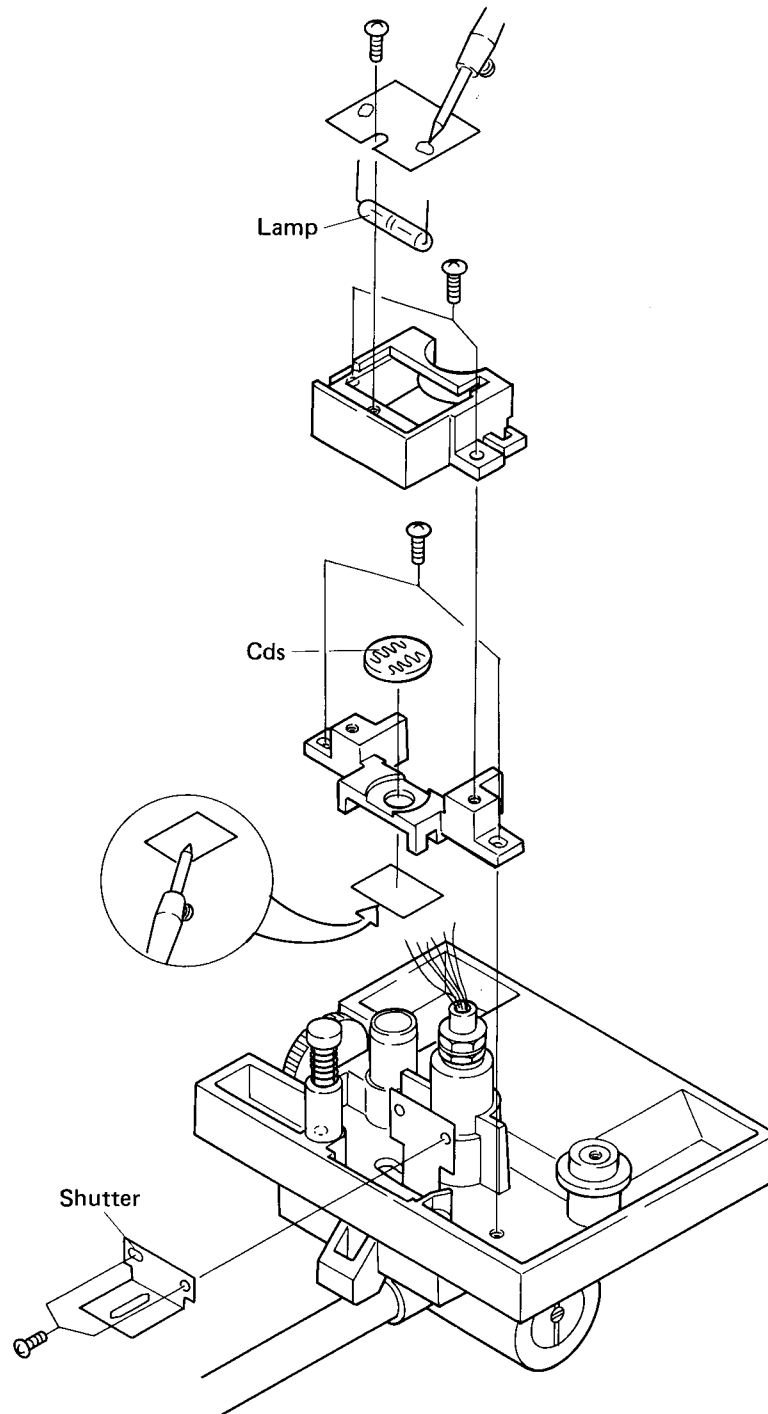
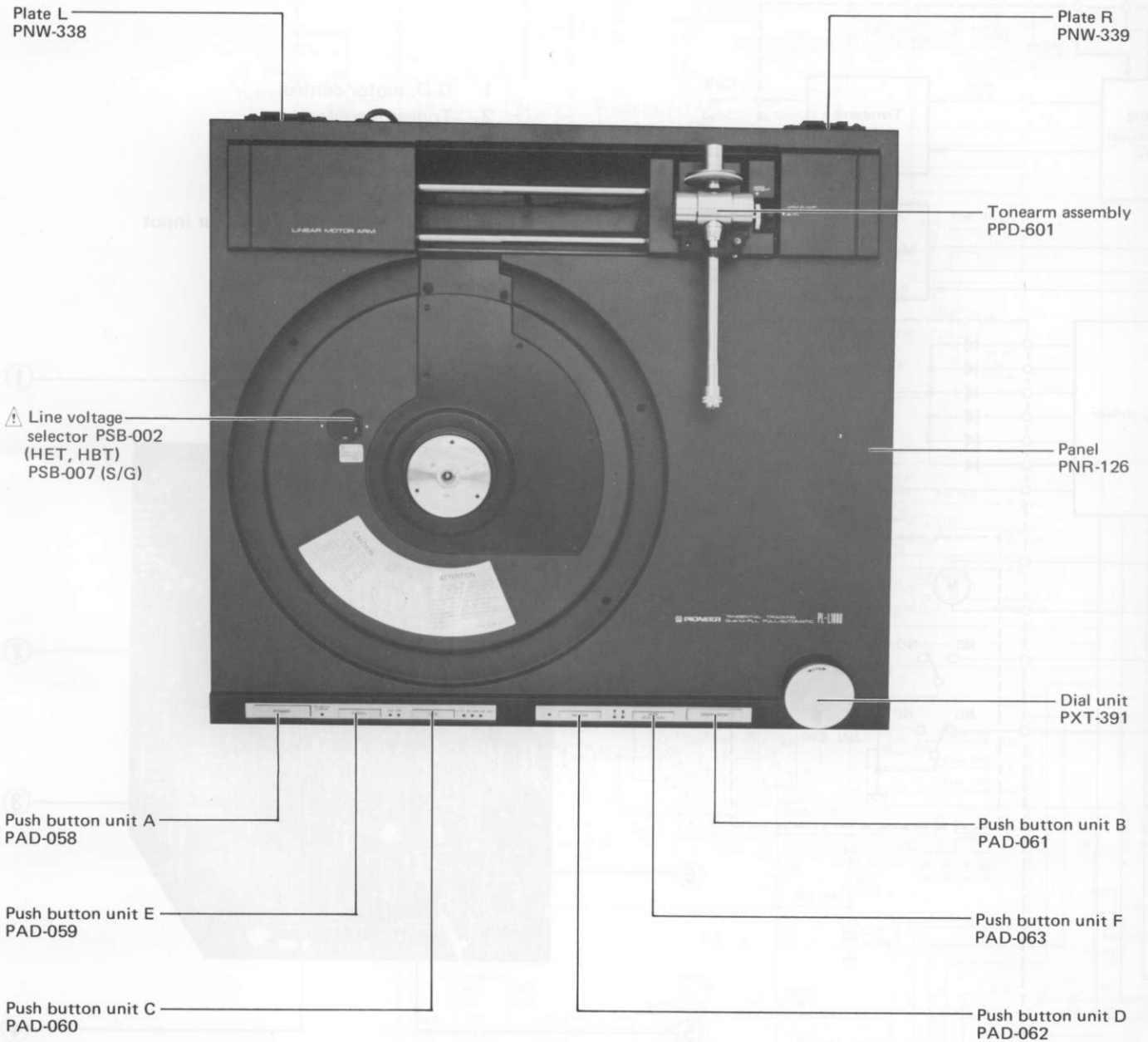

Fig. 3-5

4. PARTS LOCATIONS

- The \triangle mark found on some component parts indicates the importance of the safety factor of the part. Therefore, when replacing, be sure to use parts of identical designation.



EV mechanism assembly

(Coil assembly)
PXB-118

D.D. motor
PXB-061

Control assembly
PWM-032

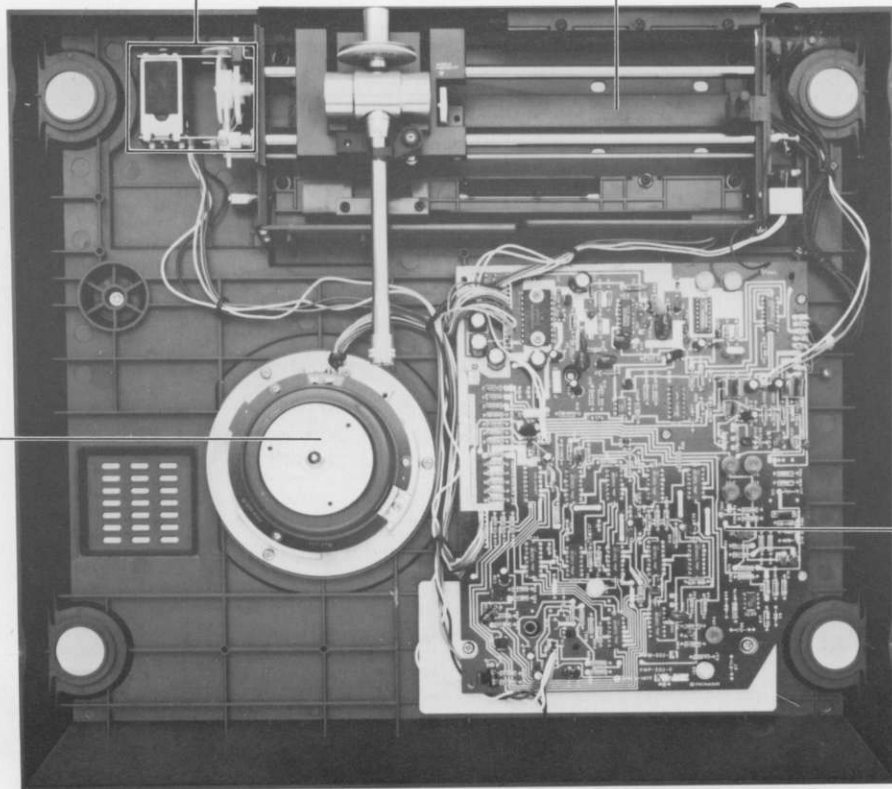

5. BLOCK DIAGRAM

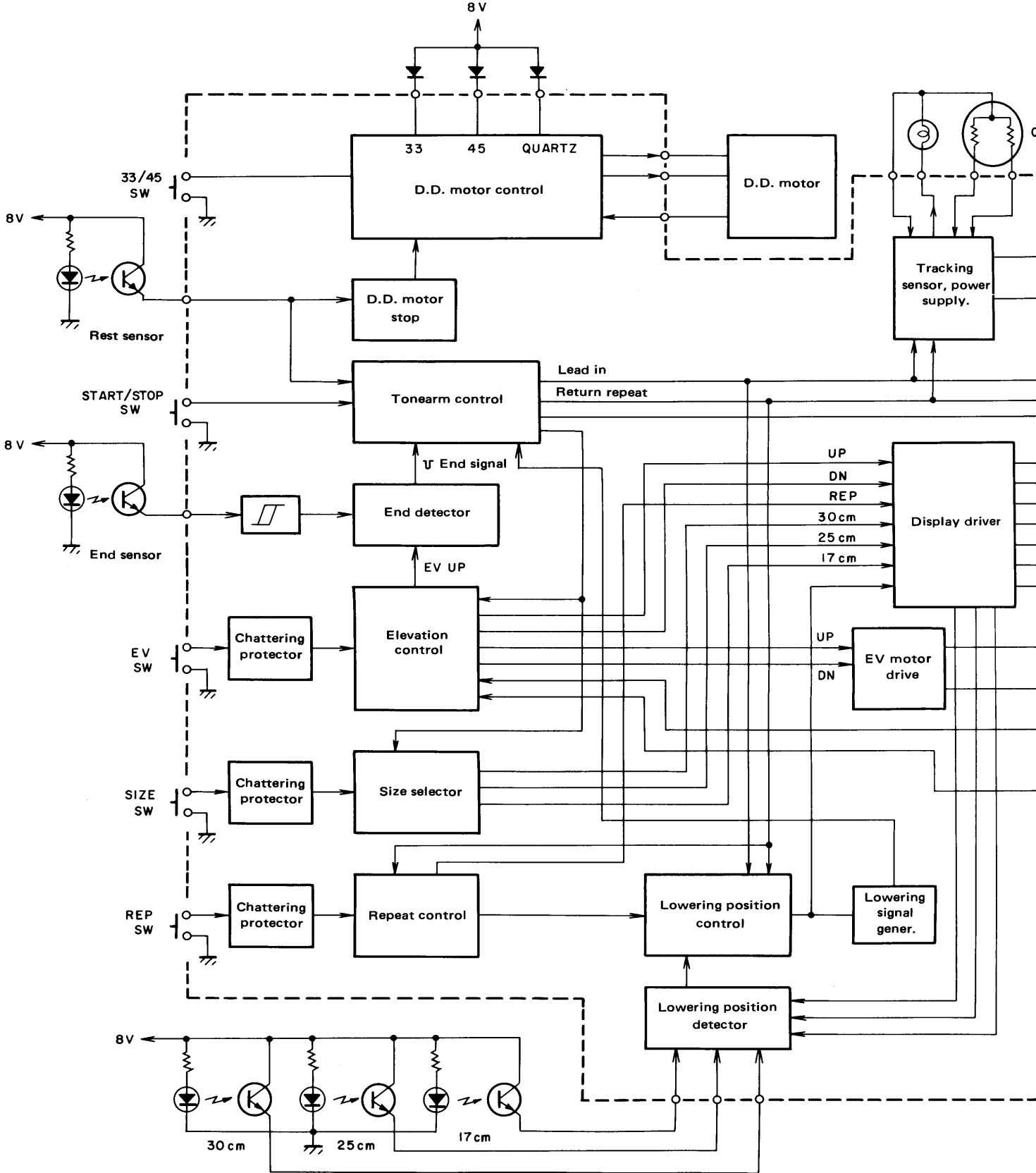

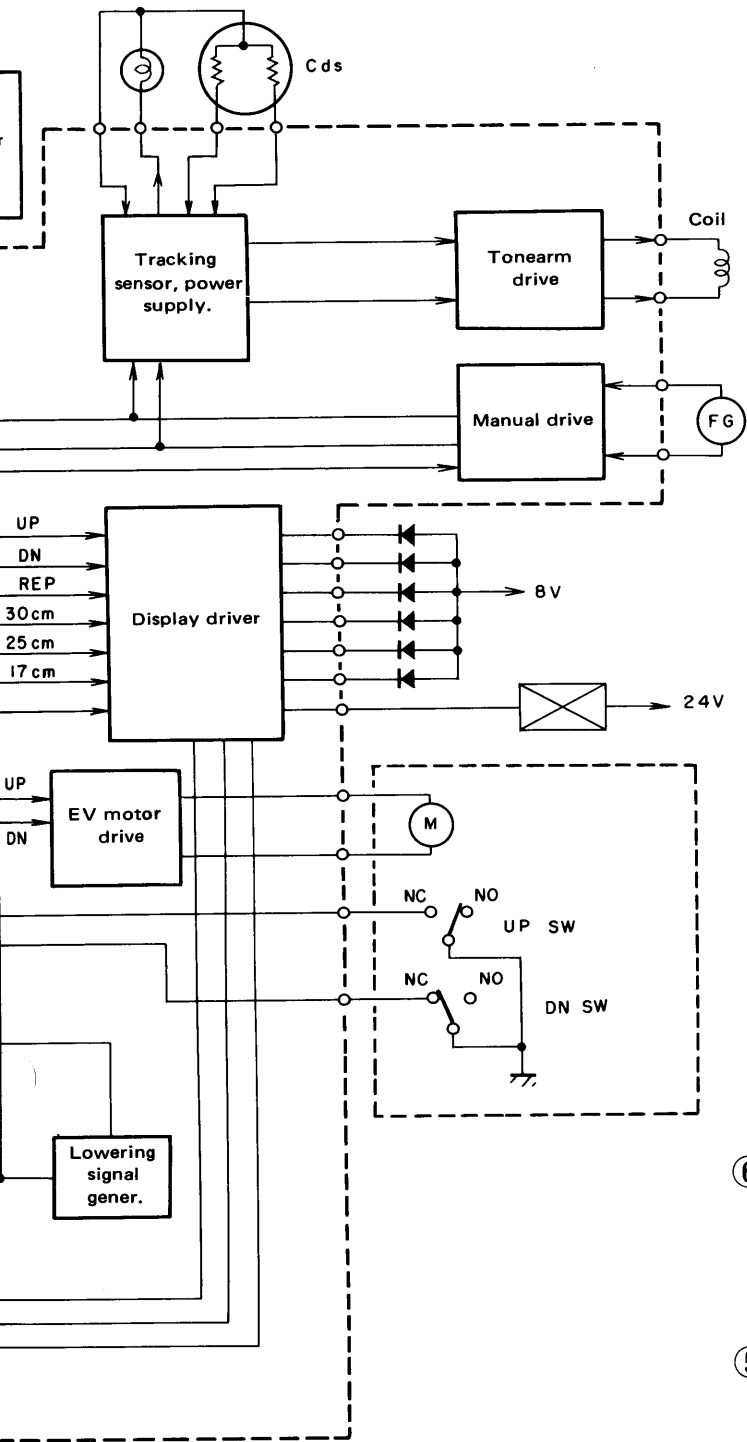

- 1 D.D. motor control
- 2 Tonearm control
- 3 Arm drive control
- 4 Full auto logic
- 5 Arm elevation control
- 6 EV, REPEAT, SIZE selector input

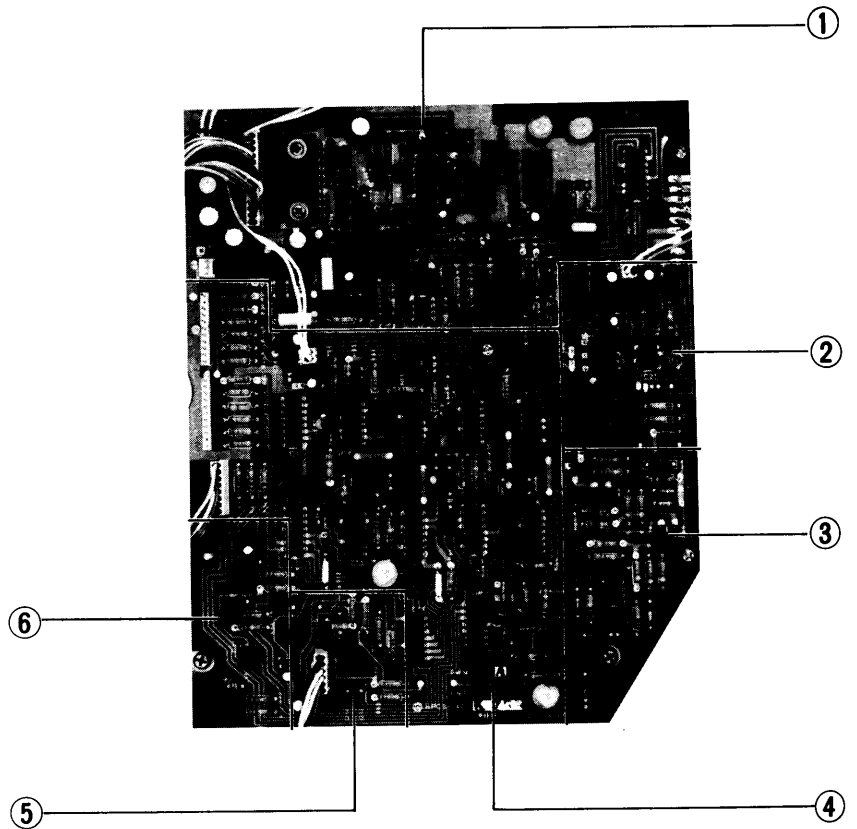

Photo 5-1

BLOCK DIAGRAM OPERATIONS

5.1 TONEARM CONTROL STAGE

a. Lead-in FF and Return FF

Lead-in FF This FF is set by pressing the S/S (START/STOP) switch when the tonearm is on the arm rest, and is reset by a descend signal, or when the power switch is turned on.

Return FF This FF is set by pressing the S/S switch when the tonearm is not on the arm rest, and also by the end detector. It is reset when the power is turned on, or by the descend signal, or when the tonearm returns to the arm rest.

b. When either of the above 2 FFs has been set, an "AUTO on" signal is generated (as well as AUTO on), resulting in the arm elevator being set to the UP position, and inhibition of manual drive.

5.2 END DETECTOR STAGE

The end sensor input signal is rectified and then applied to the detector stage consisting of a differential circuit, integration circuit, and a mono-stable multivibrator.

When the detector stage detects the arrival of 2 consecutive input signals within the fixed time constant period, an output signal is generated. This output, however, is inhibited by the EV UP signal when the arm elevator is in the UP position.

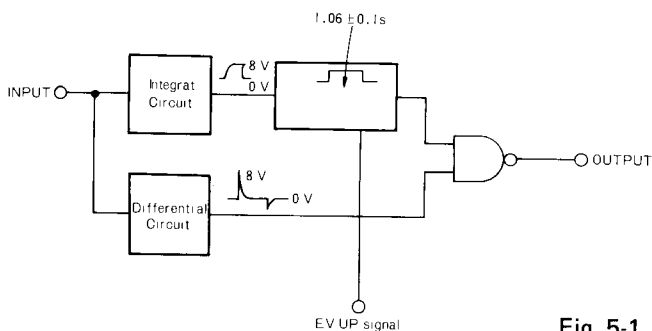

Fig. 5-1

5.3 ARM ELEVATION CONTROL STAGE

This stage consists of a J-K-type FF with a reset (clear) input and preset input.

The arm elevator is raised (UP position) as a result of the initial resetting, or by the AUTO operation signal from the tonearm control stage.

The elevator descend again (DOWN position) when the FF is preset by the descend signal. Furthermore, whenever the EV switch is pressed, Q and \bar{Q} are generated alternately, resulting in the arm elevator being raised and lowered correspondingly.

The FF output is applied to a logical "and" circuit with the outputs from the elevator UP and DOWN switches, the resultant output being applied to the EV motor drive stage.

5.4 SIZE SELECTOR STAGE

This stage consists of a J-K FF 2-stage ring counter and the Q1/Q2 logical "and" gate. As a result of the initial resetting, Q1 = Q2 = L for automatic switching of the size selector to the 30cm position. Every time the size selector switch is pressed after that, the selector is switched from the 30 to 25 and 17 positions in turn, and then back to 30 again. Note, however, that switching is inhibited when AUTO operation signals are received from the tonearm control stage (i.e. during lead-in, return, and repeat operations).

5.5 REPEAT CONTROL STAGE

Consisting of a T-type FF, Q and \bar{Q} are inverted by Repeat switch operation. Note that the FF is also turned off by the initial reset, and that there is no inversion while the tonearm control stage return FF remains set (i.e. during return and repeat operations). Furthermore, the FF is also turned off as a result of auto-cut operation during repeat mode.

5.6 LOWERING POSITION DETECTOR, PLUNGER CONTROL STAGE, AND DESCEND SIGNAL GENERATOR

When the tonearm shutter passes between the sensors corresponding to the designated record size (sensors being mounted in positions corresponding to each record size), a lowering position detector output signal is generated. This signal is then applied to the plunger control stage (a mono-stable multivibrator), resulting in a fixed time constant pulse signal being generated to activate the plunger (during lead-in and repeat modes). The down stroke of the pulse signal is differentiated and a descend position signal generated. Each of the tonearm control stage FFs is also cleared.

5.7 DISPLAY STAGE AND PLUNGER DRIVER

This stage is responsible for the LED display of elevator position, repeat mode, and selected record size, in addition to plunger drive.

5.8 MANUAL DRIVE STAGE

By amplifying the input to the power generator motor mounted in the locate stage, the tracking sensor stage balance is upset, permitting the tonearm to be moved back and forth. Such operation is inhibited, however, when the elevator is DOWN during auto operation modes (lead-in, return, and repeat).

5.9 TRACKING SENSOR STAGE AND TONEARM DRIVER STAGE

The tracking sensor stage (consisting of lamp, CdS element, and shutter) generates + and - voltage differences in response to tonearm movement. These output signals are then applied to the driver stage where they are amplified, and to pass a current through the drive coil to drive the tonearm in such a way as to eliminate tracking error (i.e. to avoid the generation of tracking sensor outputs).

5.10 D.D. MOTOR CONTROL STAGE AND D.D. MOTOR STOP CONTROL

The phono motor stop control stage stops the motor when the rest sensor detects the presence of the tonearm back on the arm rest. As long as the tonearm remains off the arm rest, the motor will continue to rotate. The phono motor control stage employs 3 specially designed ICs — PA2005, PA2004, and PD1003. These control stages also include the speed selector, speed indicator, and quartz lock indicator circuits.

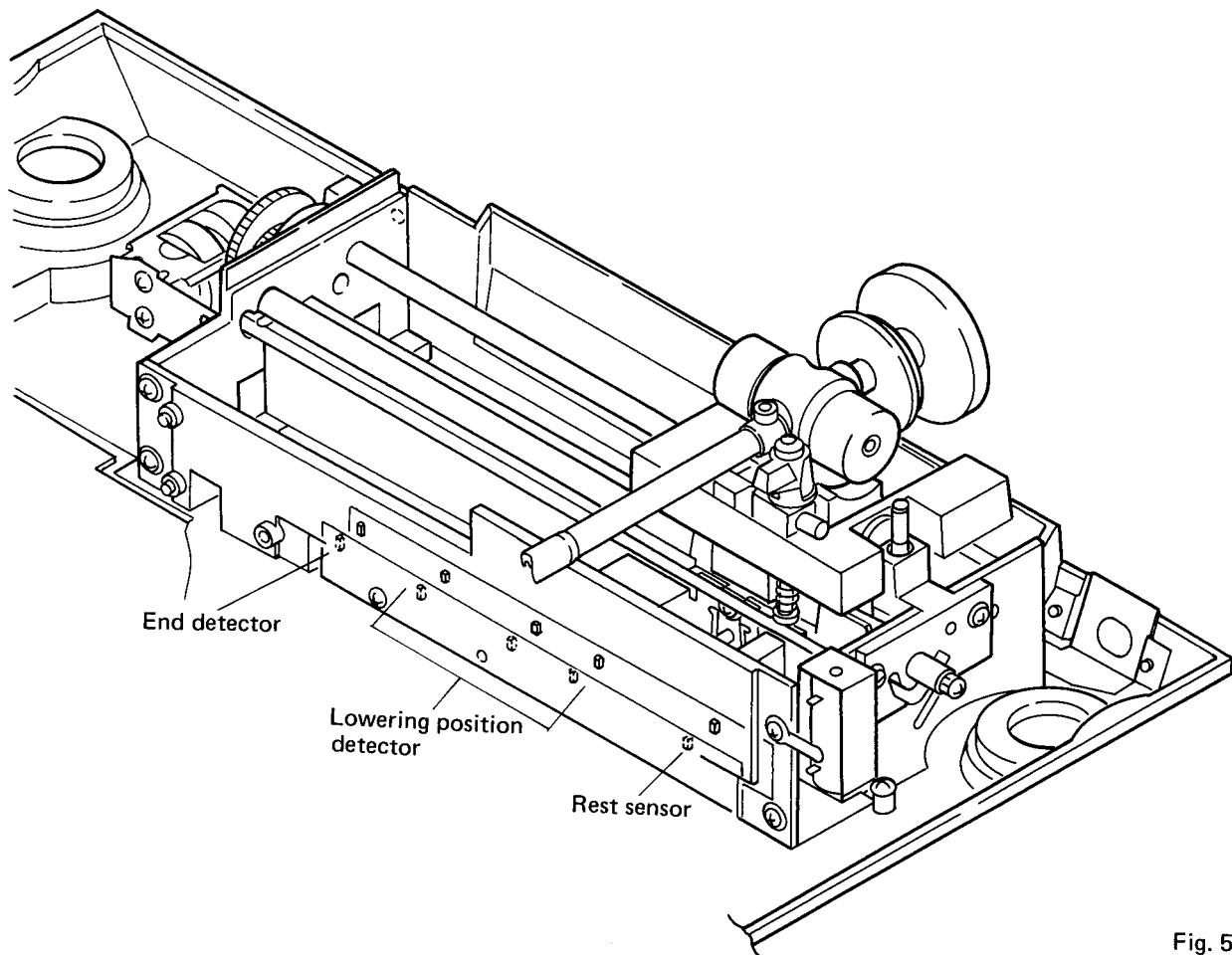
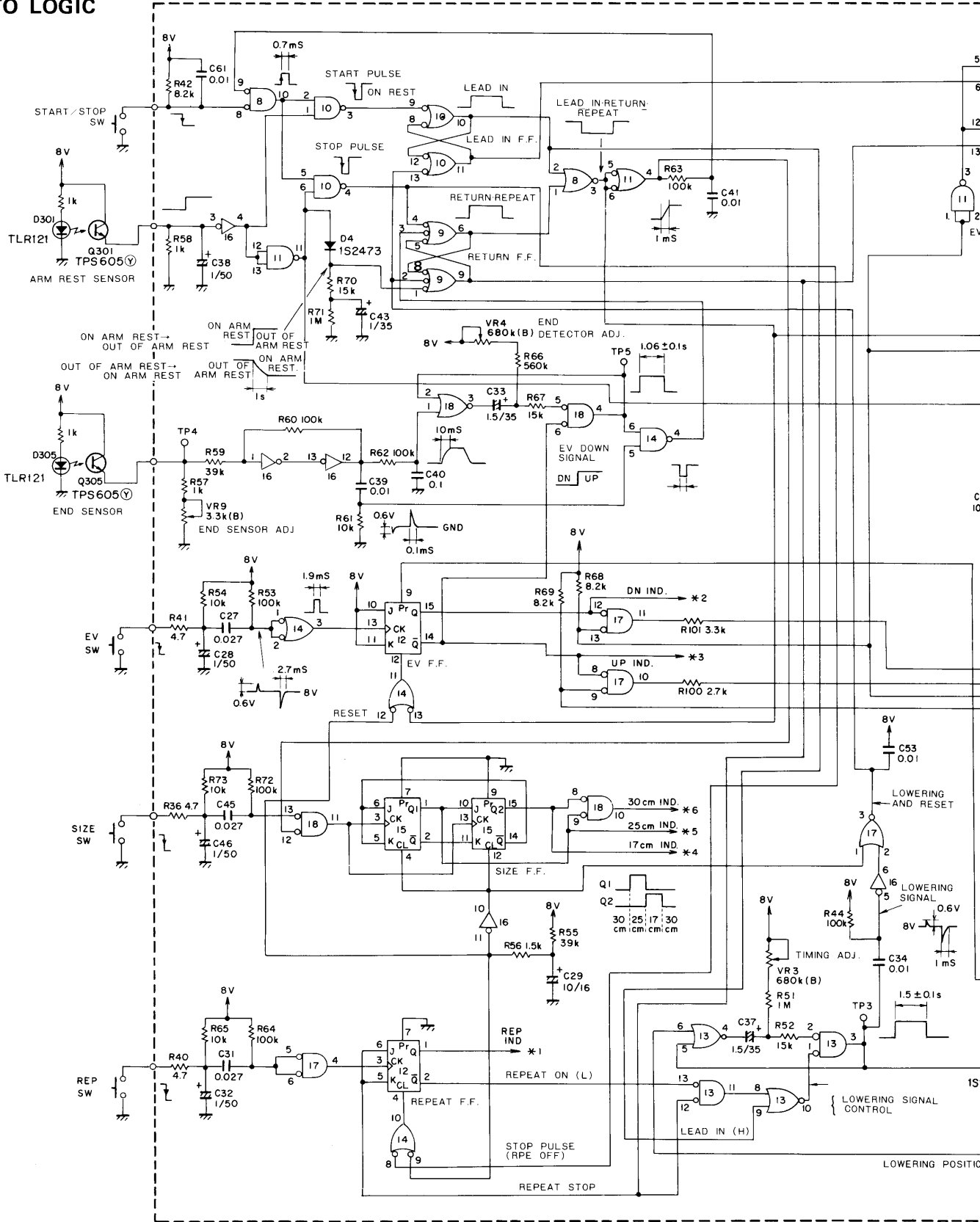
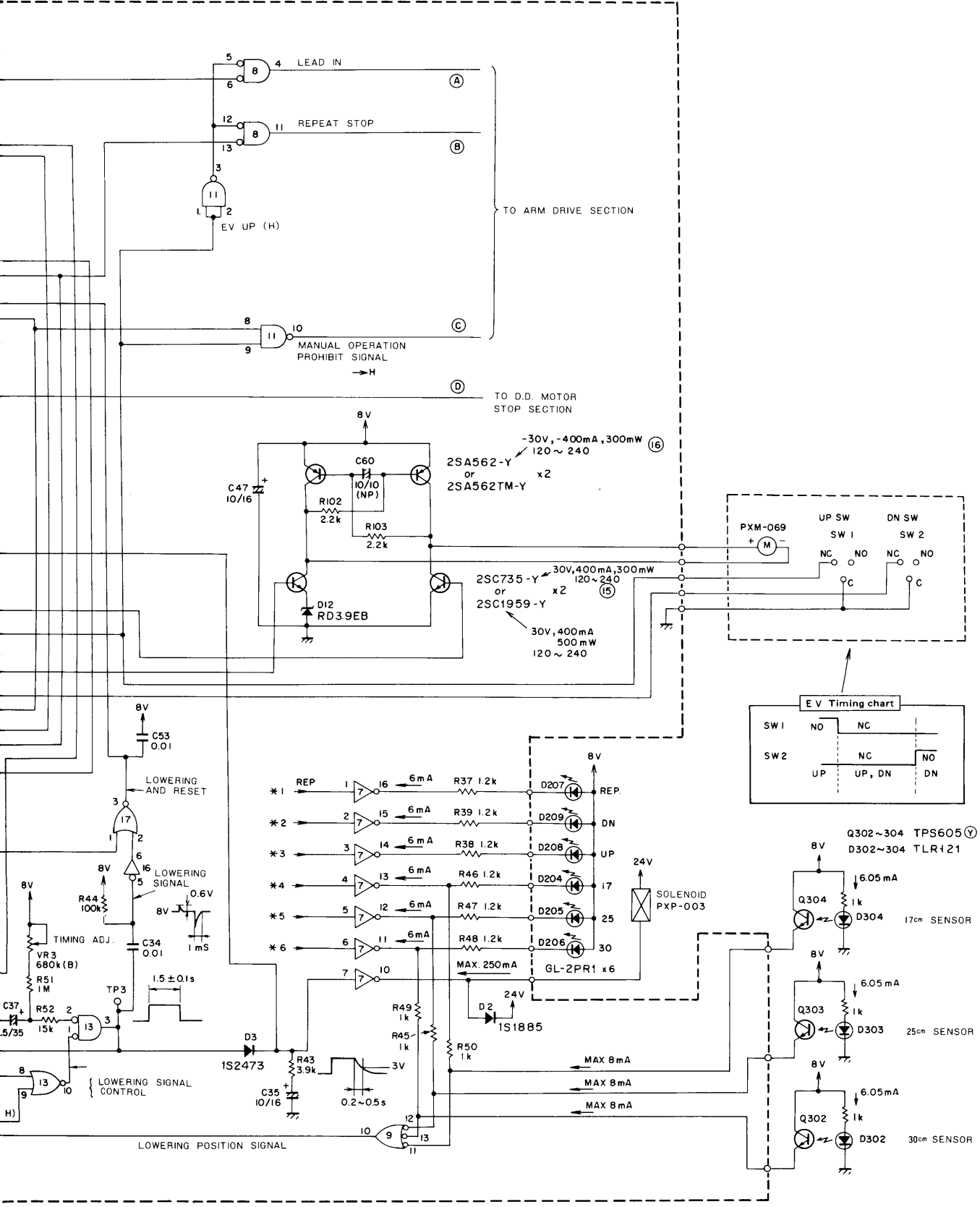

Fig. 5-2

6. CIRCUIT DESCRIPTIONS

6.1 FULL AUTO LOGIC





TO ARM DRIVE SECTION

TO D.D. MOTOR STOP SECTION

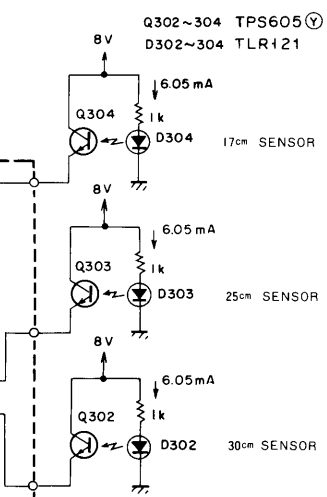
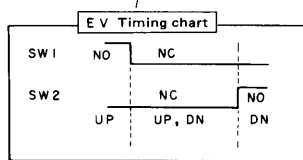
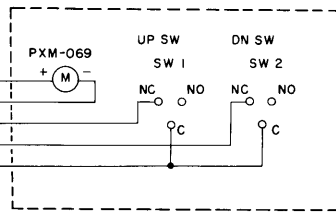

LOWERING POSITION SIGNAL

MAX 8mA

MAX 8mA

MAX 8mA

MAX 8mA

MAX 8mA

MAX 8mA

MAX 8mA

MAX 8mA

MAX 8mA

MAX 8mA

- * Number in parenthesis are the IC pin numbers.
- * L denotes L level.
- * H denotes H level.
- * EV denotes arm elevator, UP denotes that arm elevator is in UP position, while DN that elevator is in the DOWN position.

The Full Auto Logic section is made up of the following 5 main stages.

- (1) Tonearm control stage
- (2) End detector stage
- (3) Elevation control stage
- (4) Record size selector stage
- (5) Repeat control stage

6.1.1 TONEARM CONTROL STAGE

1. When the power switch is turned on

- the lead-in FF and return FF are reset by the initial reset signal (passed from C29/R55 to IC16, →IC17, →IC9, and IC10).
- the phono motor will remain stationary if the tonearm is on the arm rest, but commence to rotate if it has already been moved away.

2. When the START/STOP switch is then pressed with the tonearm on the arm rest,

- * Pin (8) of IC8 is switched to L level.
 - * Pin (10) of IC8 is switched to H level, and this appears at pin (3) of IC10, resulting in the lead-in FF being set (and pin (10) of IC10 also being switched to H level).
 - * Once pin (10) of IC10 is switched to H level, pin (3) of IC8 is switched to L level, resulting in pin (8) of IC11 being likewise switched to L level, thereby inhibiting manual drive (locate operation).
- Pin (13) of IC14 is also switched to L level, resulting in pin (12) of IC12 being switched to H level, and the elevator being consequently raised to the UP position.
- * Pin (4) of IC11 is switched to H level, resulting in the inhibition of any further START/STOP switch inputs after a delay of about 1ms (in order to prevent the return FF from being set when the tonearm leaves the arm rest). At the same time, pin (12) of IC18 is switched to H level to inhibit switching of the size selector.

Hence, the relevant FFs are set, the arm elevator raised, and record size selector switching inhibited.

- * Pin (11) of IC10 is switched to L, and this is transferred to pin (6) of IC8. Once the elevator is properly in the UP position, the UP detector switch is switched to the NO position, resulting in pin (5) of IC8 being switched to L level, and pin (4) of IC8 switched to H level.
- * This IC8 pin (4) H level signal then turns Q7 on, resulting in a current being passed from VR8 to VR5 and R99 via R93. If the potential at TP8 drops below the potential at TP10, the difference is amplified and a current passed through the coil to subsequently drive the carrier.

The carrier is thus shifted across towards the record. (Assume size selector set to 30cm).

- * When the carrier reaches a position about 20mm in front of the 30cm position, the carrier shutter will block the light of the 30cm sensor.
- * Pin (13) of IC9 is thereby switched to L level, and pin (10) of IC9 switched to H level. This serves as a trigger for the monostable multivibrator incorporated in IC13, resulting in the generation of an H level signal of $\tau = 2.2$ sec. This is applied to TP3 and pin (9) of IC12, presetting the EV FF for lowering of the tonearm.
- * The TP3 H level signal is used to drive IC7, and in turn attracts the plunger and raise the index plate.

The carrier continues to move further, coming to a stop when the swing pin strikes the index plate.

- * TP3 is switched back to L level 2.2 seconds later, the signal being differentiated by C34 and R44 to provide the tonearm descend signal which is passed via IC17, IC9 and IC10 to clear the FFs and stop the carrier drive current. The elevator UP, locate inhibition, and size selector switching inhibition are also cancelled at the same time.
- * As a further result of TP3 being switched to L level, the charge held by C35 is discharged via R43 and the IC7 base resistance. During this discharge period (0.3 to 0.5 sec.) the plunger is maintained in the attracted position, but is forced back (by a spring) once the discharge has been completed. The elevator is thereby returned to DOWN position for start of play.

3. START/STOP switch pressed when tonearm is not on the arm rest

- * Pin (8) of IC8 is switched to L level.
- * The IC8 pin (10) change to H level results in pin (4) of IC10 being changed to L level for the return FF to be set.
- * This then results in the elevator being raised, and inhibition of size selector switching, S/S switch input after a delay of 1ms, and locate.
- * The L level signal on pin (9) of IC9 is transferred to pins (5) and (6) of IC12, thereby inhibiting inversion of the repeat FF. Furthermore, the IC10 pin (4) L level change is transferred to pin (4) of IC12 via pin (8) of IC14 to clear the repeat FF. The purpose of the 1ms delay circuit referred to above is to permit sufficient time for the generation of the time pulse employed in clearing this FF.
- * In a similar fashion to the lead-in operation, the L level signal appearing at pin (9) of IC9 once the elevator has been completely raised, is converted into an H signal at pin (11) of IC8, resulting in Q8 being turned on. In this case, however, the TP10 potential drops below the TP8 potential, resulting in the carrier being returned towards the arm rest.
- * When the shutter cuts across the sensor light beam during the return motion, pin (10) of IC9 is switched to H level, but since the repeat mode has been switched off, pin (1) of IC13 will be at H level, thereby preventing operation of the monostable multivibrator.
- * Once the carrier reaches the arm rest position, the rest sensor transfers and L level signal to pin (3) of IC16, resulting in pin (11) of IC11 being switched to L level to stop the phono motor.
- * When pin (11) of IC11 is switched to L level, the charge stored on C43 is discharged via R71, the return FF being cleared after the potential on pin (1) of IC9 is reduced to $1/2V_{cc}$ (delay circuit). During this period, the carrier remains pressed against the arm rest.

4. End detector operation

- * When the repeat mode is off, pin (3) of IC9 is switched to L level by the end detector, and the return FF is consequently set. Subsequent steps are the same as during normal return mode.
- * When the repeat mode is on, the return FF is again set in the same way for normal return operation. However, when the shutter cuts across the size sensor, the plunger is activated

(TP3 switched to H level), followed by the generation of the descend signal in the same way as during lead-in. The elevator is thus lowered for recommencement of play.

6.1.2 END DETECTOR STAGE

1. Detector Principle

- * Shutter structure

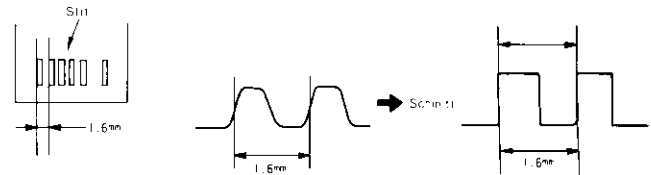

Fig. 6-1-1

Fig. 6-1-2

Fig. 6-1-3

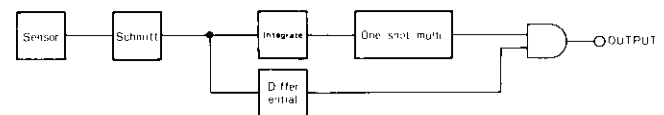

Fig. 6-2

That is, the detector circuit (outlined in the above block diagram) has been designed to detect the presence of 2 rising edges of the Schmitt circuit output within 1.06 ± 0.1 seconds

2. Circuit Description

The end sensor is mounted at a position R49mm from the spindle. When the left edge of the shutter slits reaches that position, the stylus tip will be at the R62.5mm position. That is, there is 20mm between the 62.5mm position and the point of entry into the detection range. Once the detection range is entered, the sensor commences to generate output signals with a waveform like that shown in Fig. 6-1-2 above. This output is applied to the Schmitt trigger circuit composed of 2 inverters in IC16 where it is rectified into the square wave as shown in Fig. 6-1-3. This output is then differentiated by C39/R61 and applied to pin (5) of IC14, while another portion of the same output is integrated by R62/C40 and applied to the monostable multivibrator composed of 2 NOR gates in IC18, resulting in the generation of a 1.06 ± 0.1 sec H level signal. (TP5). Although this signal is applied to pin (6) of IC14, there is no detection by pin (5) because of the delay by the integration circuit. If, however, the next differential pulse is applied to pin (5) of IC14 while the H level signal is being generated at TP5, that pulse will be detected. Apart from this case, there is no detection because the differential pulse involves a slight delay before switching TP5

to H level.

Furthermore, when the elevator $\overline{FF} \overline{Q}$ is connected to pin (6) of IC18 to make $\overline{Q} = H$ (i.e. UP position), the monostable multivibrator is inhibited, thereby inhibiting the detector circuit. $\overline{Q} = H$ also when the power switch is turned on, again inhibiting the multivibrator.

6.1.3 ELEVATION CONTROL STAGE

- * When the power switch is turned on, an initial reset signal is passed to pin (12) of IC14 from R55/C29, resulting in pin (11) of IC14 and pin (14) of IC12 being switched to H level ($\overline{Q} = H$). This corresponds to the elevator being in the UP position, or in other words, UP priority is given when the power is first turned on.
- * Since $\overline{Q} = H$, one of the IC7 transistors will be turned on to light up the UP indicator lamp.
- * Until the elevator reaches the UP position the UP detector switch remains in the NC position, resulting in pins (13) and (12) of IC17 being both switched to L level, and Q13 and Q16 of the elevator drive stage being both turned on to start up the motor.
- * Once the elevator is properly in the UP position, the UP detector switch is switched to the NO position, resulting in pin (13) of IC17 being switched to H level, and pin (11) of IC17 being switched to L level. Q13 and Q16 are both turned off and the motor stopped.
- * If the elevator switch is then pressed, a falling edge differential pulse is generated on pins (1) and (2) of IC14, and a rising edge clock pulse on pin (13) of IC12. This results in $Q = H$ and $\overline{Q} = L$ for lowering of the elevator (DN).
- * And since $Q = H$, the DN indicator lamp will be lit up, and the UP indicator turned off.
- * The DN detector switch remains in the NC position until the elevator is right down. During this period, pins (9) and (8) of IC17 will be both at L level, while pin (10) of IC17 will be at H level. The elevator drive stage Q14 and Q15 will thus be on and the motor rotating.
- * If the elevator switch is pressed during this condition, Q will switch to L and \overline{Q} to H (UP) to reverse the motor.

The above description relates to the operation of the elevator circuit itself. In addition,

- * automatic mode UP (as described under the tonearm control stage), and
 - * DN at the lowering position,
- may be controlled via the elevator FF preset and clear terminals.

6.1.4 RECORD SIZE SELECTOR STAGE

- * When the power is turned on, the initial reset signal from R55/C29 is passed to IC16 to switch pin (11) to H level, resulting in IC15 being cleared.
- * Pin (1) (Q1) and pin (15) (Q2) of IC15 are both switched to L level, this then being transferred to pins (8) and (9) of IC18. Pin (10) of IC18 is thus switched to H level and the 30cm indicator lamp is lit up.
- * If the size selector is then pressed, the falling edge differential pulse applied to pin (13) of IC18 when pin (12) of this IC was at L level (i.e. when none of the lead-in, return, or repeat modes was operative), is instead applied to pin (11) of IC18 as a rising edge clock pulse, thereby activating the ring counter in IC15. As a result, Q1 = H and Q2 = L. The 30cm indicator lamp is turned off, and the 25cm indicator lamp turned on.
- * If the size selector is pressed again, the 17cm indicator lamp is turned on. Every time the selector is pressed, the size is switched in a cyclic order 30 → 25 → 17.

6.1.5 REPEAT CONTROL STAGE

- * When the power is turned on, the initial reset signal from R55/C29 is applied to pin (8) of IC14, resulting in pin (10) of this IC being switched to H level, and pin (1) (Q) of IC12 being switched to L level.
- * The repeat indicator lamp will thus be turned off (since $Q = L$).
- * If the repeat switch is then pressed, a falling edge differential pulse will be applied to pins (5) and (6) of IC17, and a rising edge clock pulse generated at pin (4). As long as the repeat or return modes are not operative at this time, pin (5) (K) and (6) (J) of IC12 will both be at H level, resulting in $Q = H$, and $\overline{Q} = L$ for the repeat indicator to be turned on. At the same time, pin (13) of IC13 is switched to L level, thereby enabling the monostable multivibrator consisting of 2 gate circuits in IC13 to operate during repeat.
- * If the repeat switch is then pressed again, the $J = K = H$ status will be inverted.

In addition to the above repeat control stage,

- * The START/STOP switch may be pressed to activate return mode. In this case, a falling edge pulse is generated on pin (4) of IC10, and then applied to pin (8) of IC14. Pin (10) of IC14 is thus switched to H level, and the IC12 FF cleared (repeat off), resulting in $Q = L$ and $\overline{Q} = H$.

- * When the return FF is set (during return or repeat mode), pin (9) of IC9 is switched to L level, this being transferred to the J and K terminals of the repeat FF, thereby inhibiting any inversion.

6.2 TONEARM DRIVE

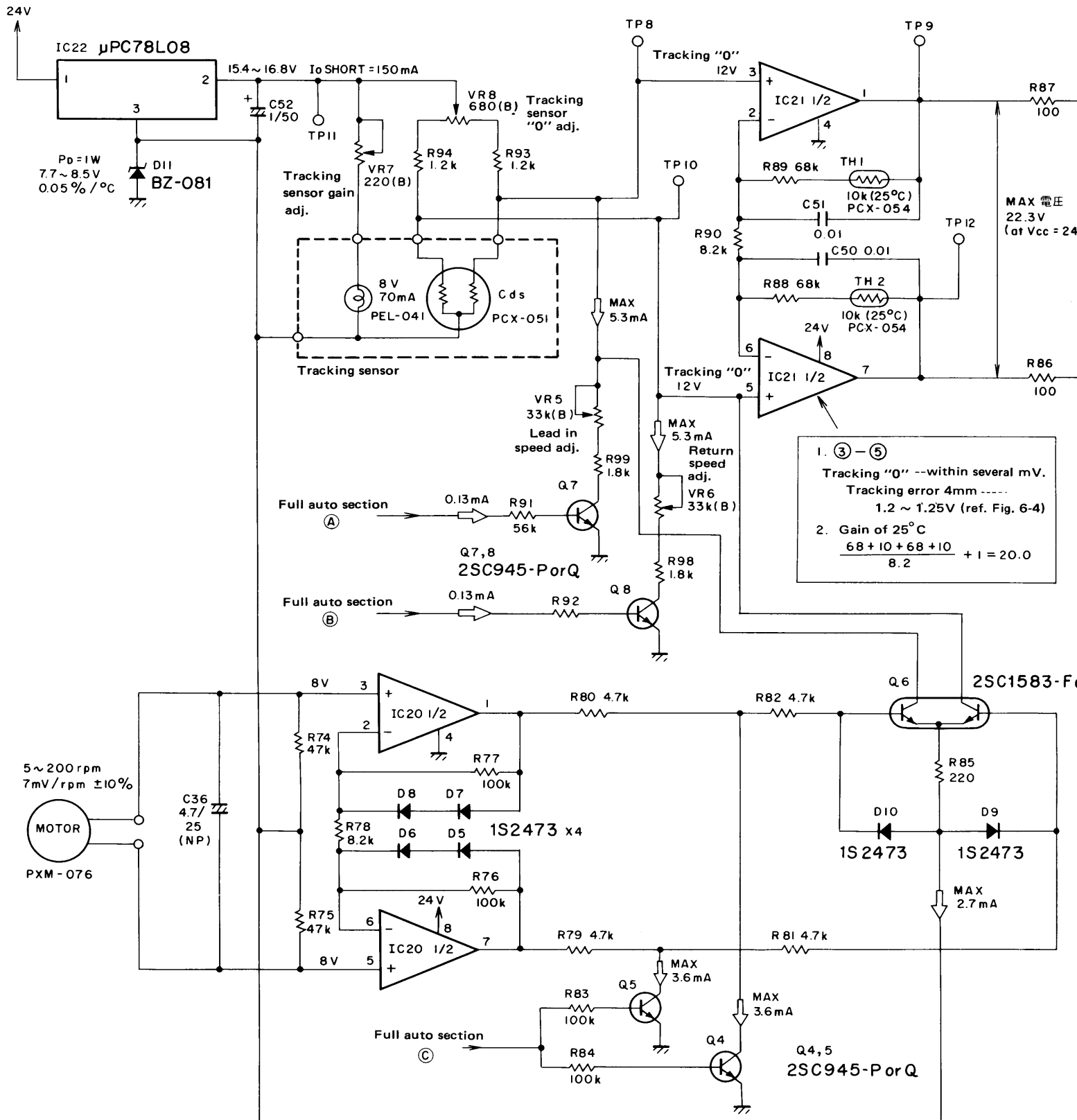

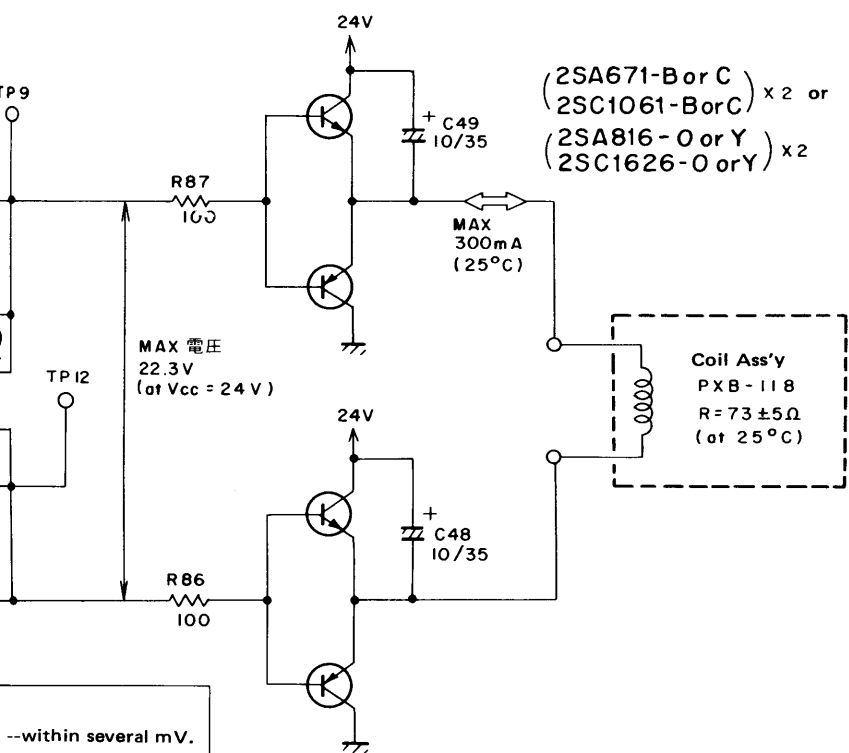

--within several mV.
 Error 4mm -----
 1.25V (ref. Fig. 6-4)
 °C
 $\frac{68 + 10}{1} + 1 = 20.0$

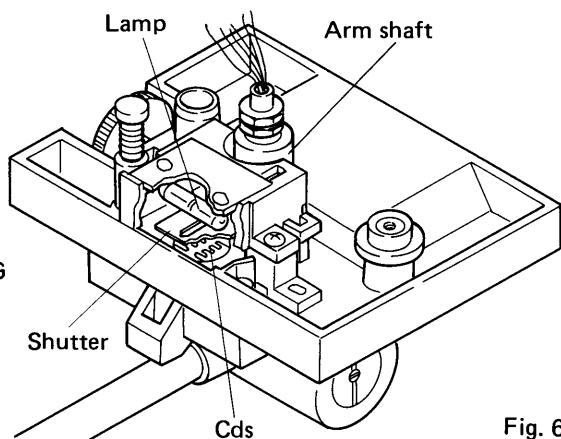
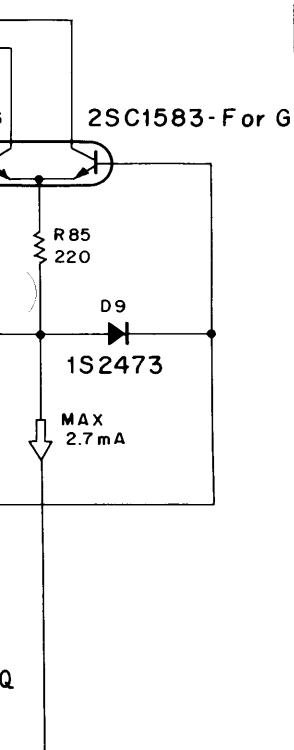

Fig. 6-3

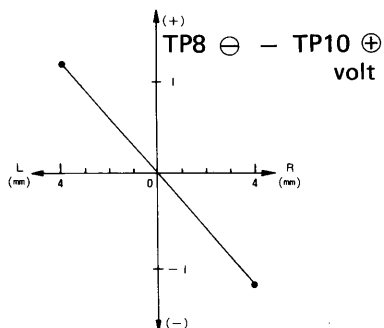

Fig. 6-4

The tonearm drive stage contains the following 3 major component circuits.

- (1) Tracking sensor circuit
- (2) Tonearm drive circuit
- (3) Manual operation circuit (locate operation circuit)

6.2.1 TRACKING SENSOR CIRCUIT

An outline of the tracking sensor circuit is shown in page 21. When the stylus is positioned exactly at right angles to the carrier, the lamp beam is directed practically equally onto both CdS elements, which means that the resistance in both elements will also be more or less equal. These 2 elements form part of a Wheatstone bridge with R93, R94, and VR8, this latter variable control being adjusted so that no potential difference is generated across TP8 and TP10 when the stylus is located at right angles to the carrier. If the stylus should happen to move to either left or right, the amount of light striking the CdS elements will change, resulting in the resistance of one element being increased, and the resistance in the other element being decreased. A potential difference will thus be generated across TP8 and TP10. The relation between stylus movement and the potential difference generated is shown in grasp form in Fig. 6-4. VR7 is used for adjustment purposes.

- * When the stylus is positioned at right angles to the carrier, the bridge is balanced, and the carrier remains stationary.
- * If the stylus should tend towards the left of the carrier, a (+) potential will be generated across TP8 and TP10: This signal is amplified in the tonearm drive circuit (sec. 2.2 below), resulting in a coil current to move the carrier to the left. (During record trace, or when moved to the left by hand).
- * If the stylus should happen to tend towards the right, a (-) potential will be generated across TP8 and TP10. After amplification in the tonearm drive circuit, the resultant coil current serves to move the carrier to the right. (During record trace, or when moved to the right by hand).
- * During lead-in Q7 is turned on, and a current is passed from R93 to R99 via VR5. A (+) potential difference is generated between TP8 and TP10 by the voltage drop across R93, resulting in the carrier being moved to the left. Speed is controlled by adjusting the current passing through VR5.

- * During return and repeat modes, Q8 is turned on, resulting in a current being passed from R94 to R98 via VR6. Consequently, a (-) potential difference is generated between TP8 and TP10 by the voltage drop across R94, thereby moving the carrier to the right. In this case, speed is controlled by adjusting the current passing through VR6.

6.2.2 TONEARM DRIVE CIRCUIT

The tonearm drive circuit consists of a current booster formed by a differential amplifier and Q9 ~ Q12.

1. Differential amplifier

Consisting of a pair of op amps.

6.2.3 MANUAL OPERATION CIRCUIT (LOCATE OPERATION CIRCUIT)

- * When elevator not completely in UP position (UP detector switch in NC position).
- * During automatic modes (lead-in, return, repeat). Under the above conditions, pin (10) of IC11 in the full auto logic stage is switched to H level, thereby turning Q4 and Q5 on. The collector voltage of these 2 transistors will thus be almost zero. Current will also flow through the D10 - R82 - Q4 and D9 - R81 - Q5 routes, resulting in the base of Q6 being biased in the reverse direction due to the voltage drop of V_F of D9 and D10 in respect to the emitter. Q6 is thus turned off to inhibit locate operation.
- * When locate dial is rotated.
- * When the motor generates power.
- * When the motor rpm is low (slow rotation of the dial), the amplifier gain is determined by

$$\frac{R76 + R77}{R78} + 1, \text{ but once the motor rpm is}$$

increased to a certain rate, the gain will be clamped by the voltage determined by D7 and D8, or D5 and D6.

- * When the differential amplifier is activated, one side of Q6 is turned on according to the rotational direction of the dial, resulting in a voltage drop across R93 or R94, and the generation of a potential difference between TP8 and TP10. This is subsequently amplified, and results in a current being passed through the coil to move the carrier.

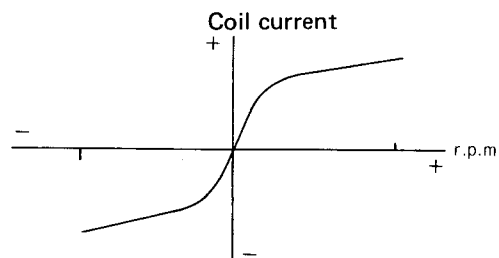

Fig. 6-5

7. ADJUSTMENTS

Adjustment position

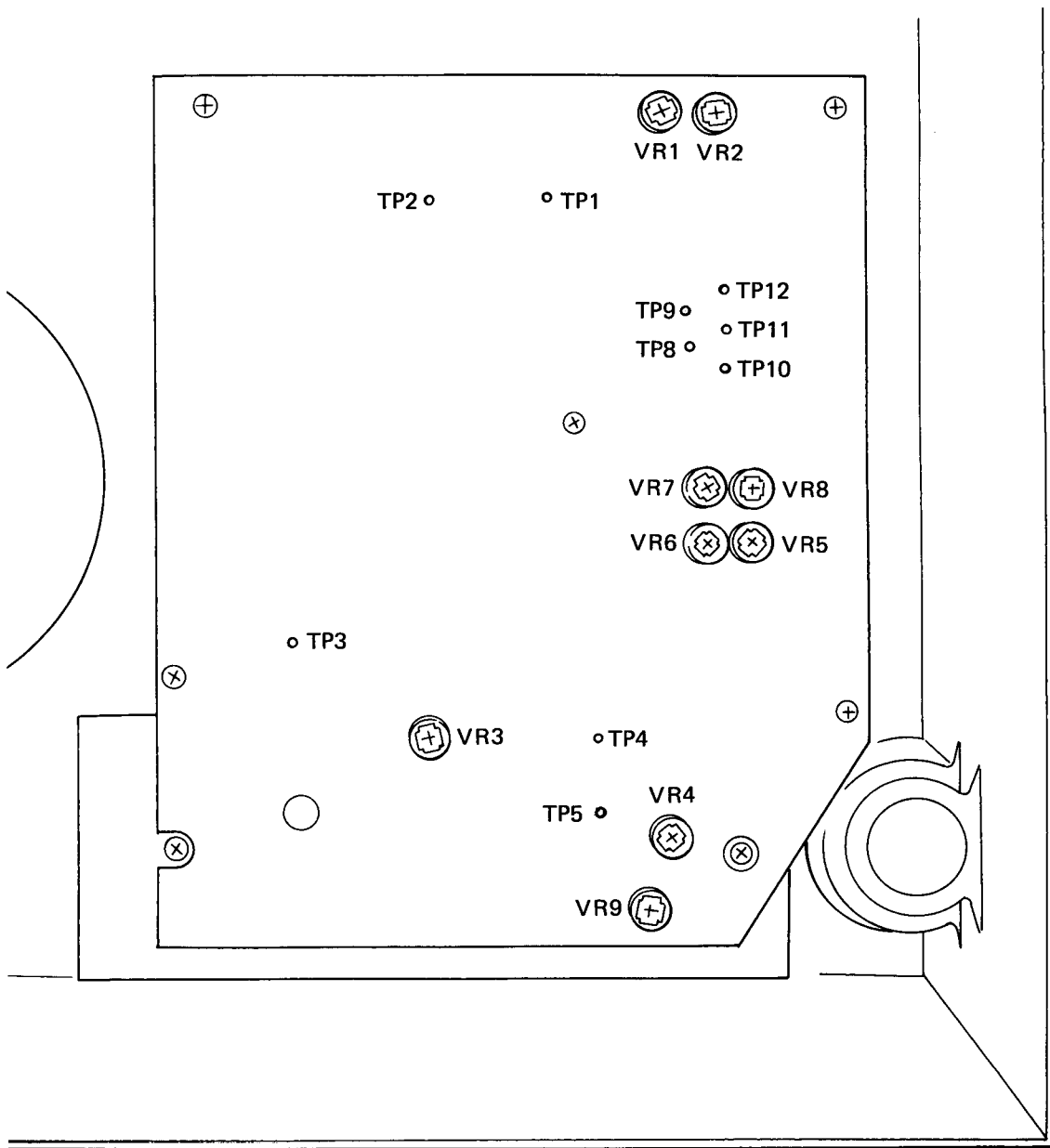

Fig. 7-1

Preparation

1. Disconnect the panel according to the disassembly method outlined earlier.
2. Use extension leads to connect the panel to the printed circuit board located in the base section.
3. Remount the turntable platter (but without tightening the securing screws).

7.1 D.D. MOTOR OPERATING POINT ADJUSTMENT

1. Connect the TP1 and TP2 terminals to the CH1 and CH2 inputs of a dual-trace oscilloscope.
2. Start the turntable platter turning by shifting the tonearm over towards the center of the record from the arm rest position.
3. Observe the waveforms in the oscilloscope, and adjust the corresponding controls so that the rising edge of the TP2 output waveform lies within the TP1 output waveform.
4. VR1 is the control to adjust for 45rpm speed, while VR2 is the control for 33rpm adjustment.

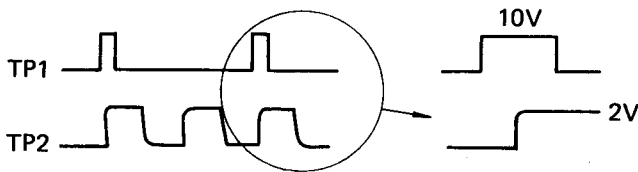

Fig. 7-2

7.2 AUTO LEAD-IN TIMING ADJUSTMENT

1. Set the record size selector to the 30cm position.
2. Press the START/STOP key to start the tonearm lead-in movement.
3. When the tonearm is about 20mm away from the outer edge of the record, an output pulse signal will appear at TP3 (see Fig. 7-3). Adjust VR3 to obtain a time constant of 2.2 ~ 2.5 sec. for this pulse signal.

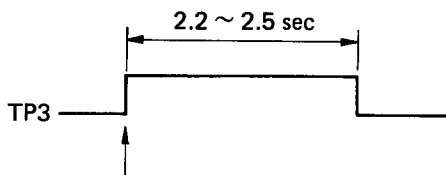

Fig. 7-3

7.3 END SENSOR SENSITIVITY ADJUSTMENT

1. Connect the oscilloscope to the TP4 terminal.
2. Set the arm elevator to the UP position, and shift the tonearm across to near the lead-out groove.
3. Hold the tonearm carrier by hand, and move the tonearm back and forth at a rate of 5 to 10cm/sec.
4. During this operation, adjust VR9 so that the TP4 output saturates at H and L levels at about 50% duty.

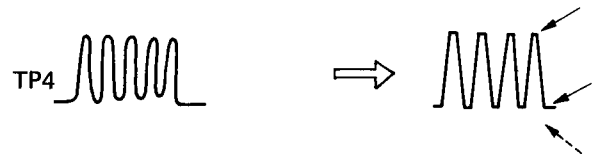

Fig. 7-4

7.4 END TIMER ADJUSTMENT

1. Connect the oscilloscope to the TP5 terminal.
2. Secure the tonearm to the arm rest, and remove the turntable platter.
3. Insert a piece of paper (or any other light shield) into the end sensor stage.
4. As soon as the piece of paper (or light shield) is removed, an output signal appears at TP5. Adjust the time constant of this output to 1.06 ± 0.1 sec by means of VR4.

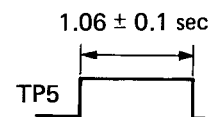
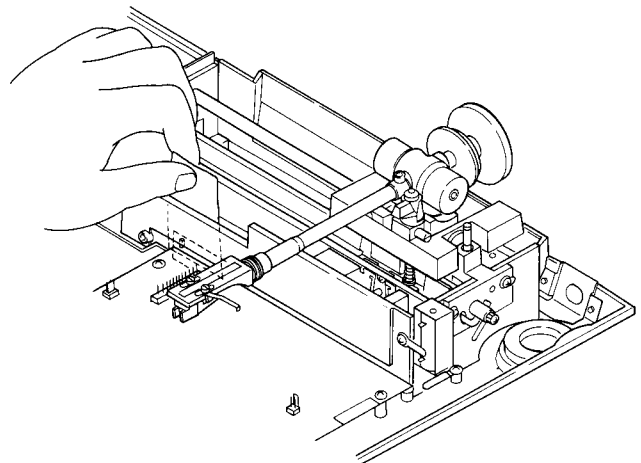

Fig. 7-5

7.5 TRACKING SENSOR ZERO POINT ADJUSTMENT

1. Set the arm elevator to the UP position, and adjust VR8 to obtain a voltage of less than $\pm 0.1V$ between TP9 (-) and TP12 (+).
2. Set the arm elevator to the UP and DOWN positions repeatedly, and also perform each of the automatic mode operations. Finally set the arm elevator back to the UP position, and check that the voltage across the TP9 and TP12 terminals remains below $\pm 0.35V$.

7.6 TRACKING SENSOR GAIN ADJUSTMENT

1. Disconnect the drive coil connector, and insert a piece of paper (or any other light shield) into the rest sensor stage and stop the DD motor rotation.
 2. Shift the tonearm across to any desired position above the turntable platter, and then fix the rail and roller to secure the carrier.
 3. With the arm elevator in the DOWN position, shift the tonearm across to a position 4mm to the left of the tonearm center position.
 4. Then adjust VR7 so as to obtain a voltage of 1.2 to 1.25V across the TP8 and TP10 terminals.
 5. Next shift the tonearm to a position 4mm to the right of the tonearm center, and check that the voltage across TP8 and TP10 varies by no more than $\pm 0.15V$ from the value measured in step 4 above.
- *1. Because of the "ghost" tendency caused by light from the tracking sensor lamp (as shown in Fig. 7-8), this adjustment must be performed with care.
- *2. Perform the above tracking sensor adjustment procedures (7.5 and 7.6) at least twice.

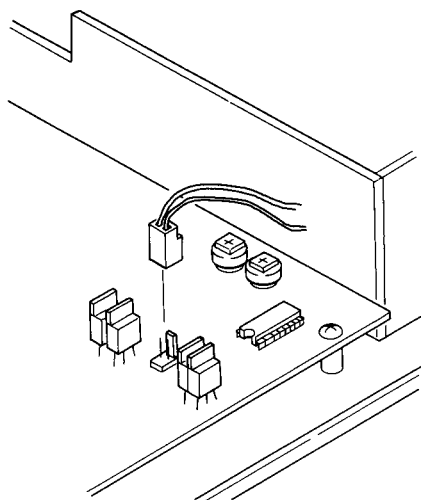

Fig. 7-6

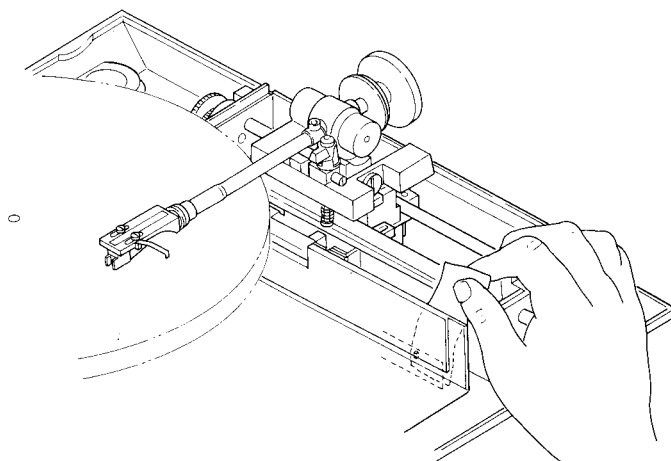

Fig. 7-7

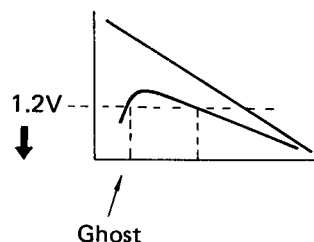

Fig. 7-8

7.7 LEAD-IN AND RETURN SPEED ADJUSTMENT

1. Set the record size selector to the 17cm position.
2. Press the START/STOP key to commence the tonearm lead-in operation.
3. Adjust VR5 so that the time required to reach the 17cm position is 5.5 to 6.5 seconds.
4. Then adjust VR6 so that the time required for the tonearm to return to rest from the 17cm position is also 5.5 to 6.5 seconds.

8. TIMING CHART

(1) LEAD IN PLAY

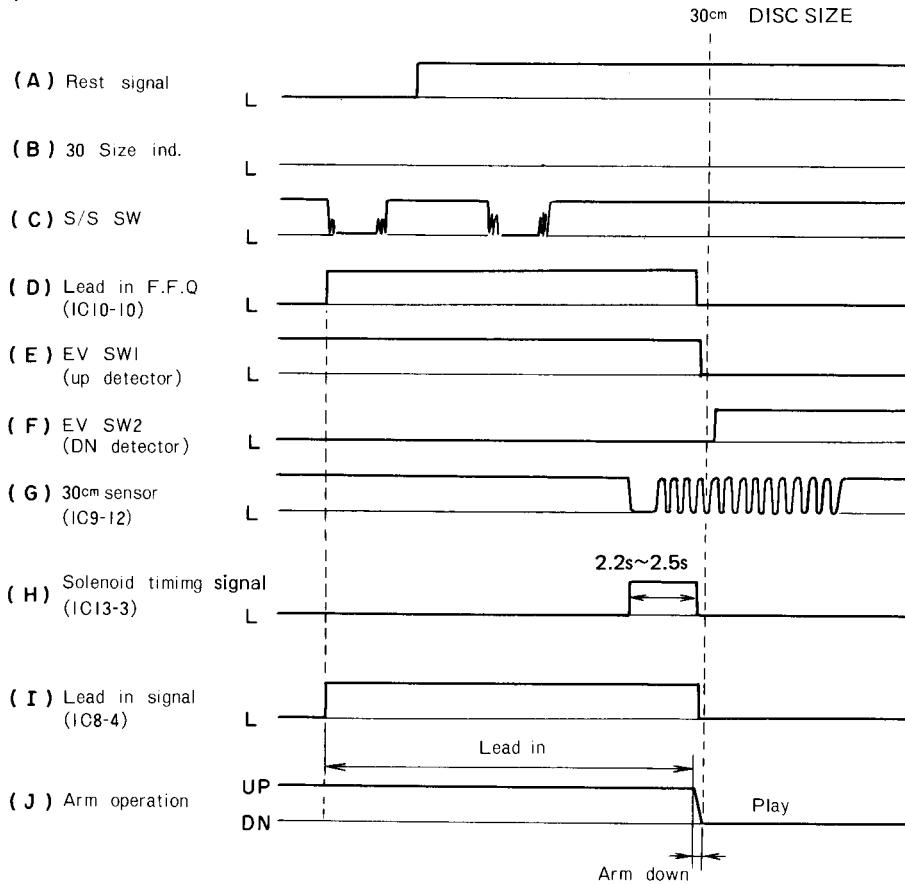

(2) REJECT

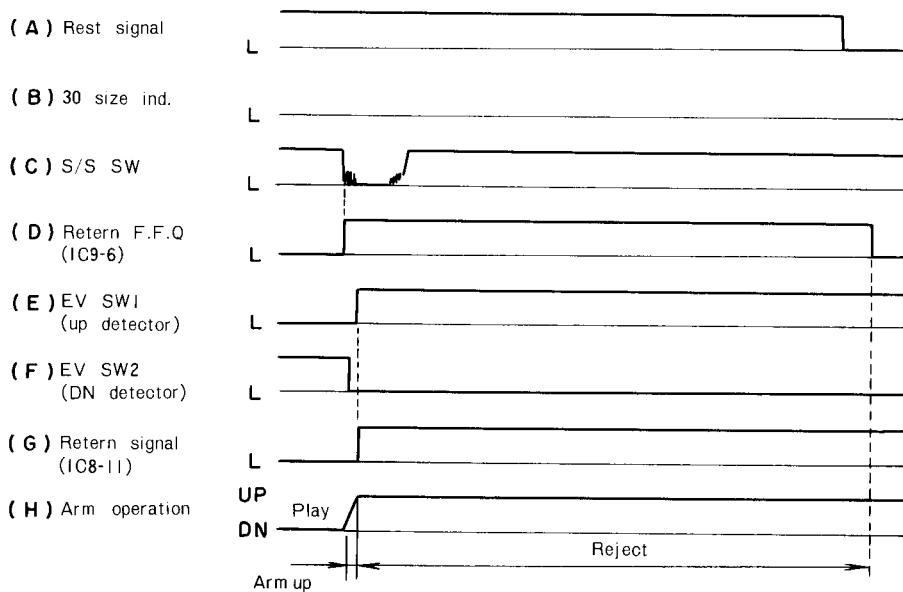

(3) REPEAT

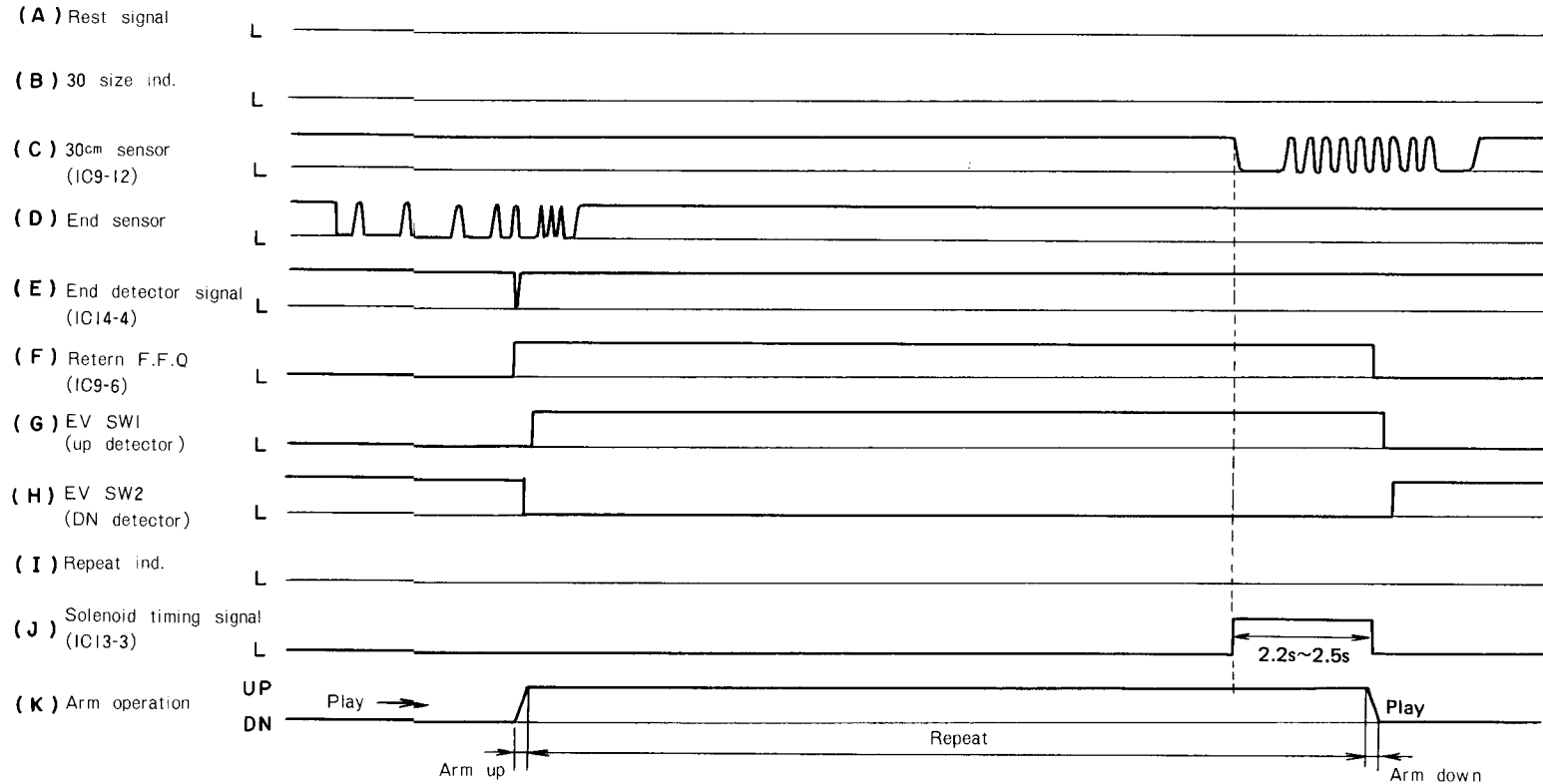

NOTES : UP — Arm elevation UP
 DN — Arm elevation DOWN
 S/S — START-STOP Switch
 F.F — FLip Flop
 EV — Elevation (Tonearm)

9. TROUBLE SHOOTING

9.1 CIRCUIT BLOCK

9.1.1

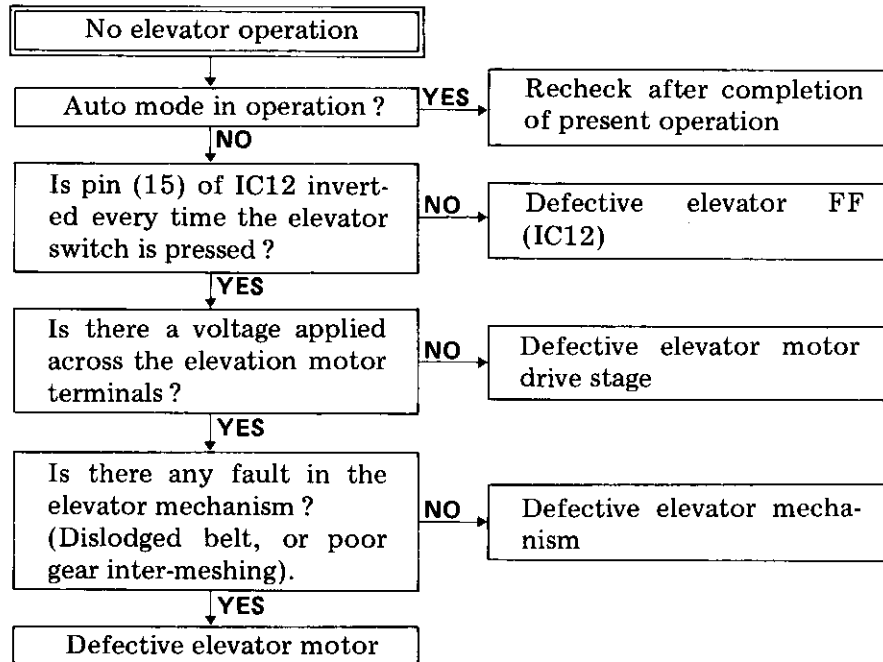

9.1.2

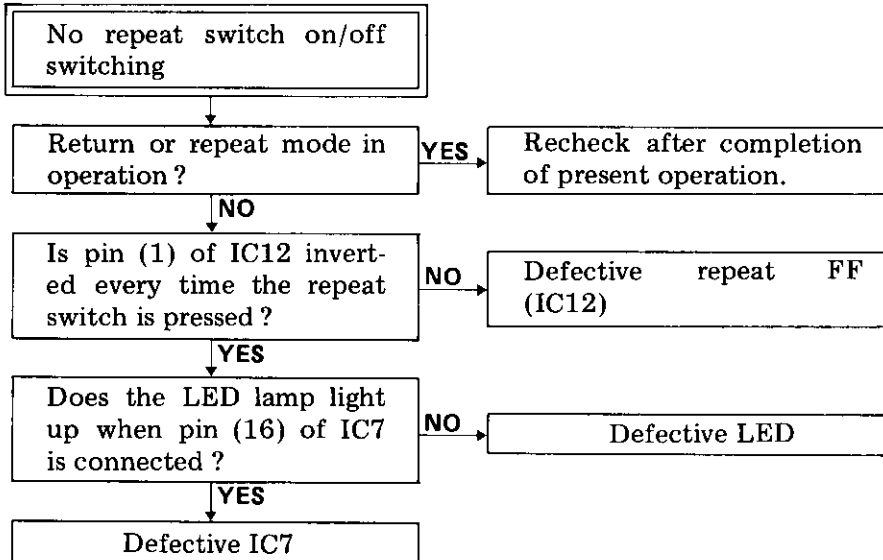

9.1.3

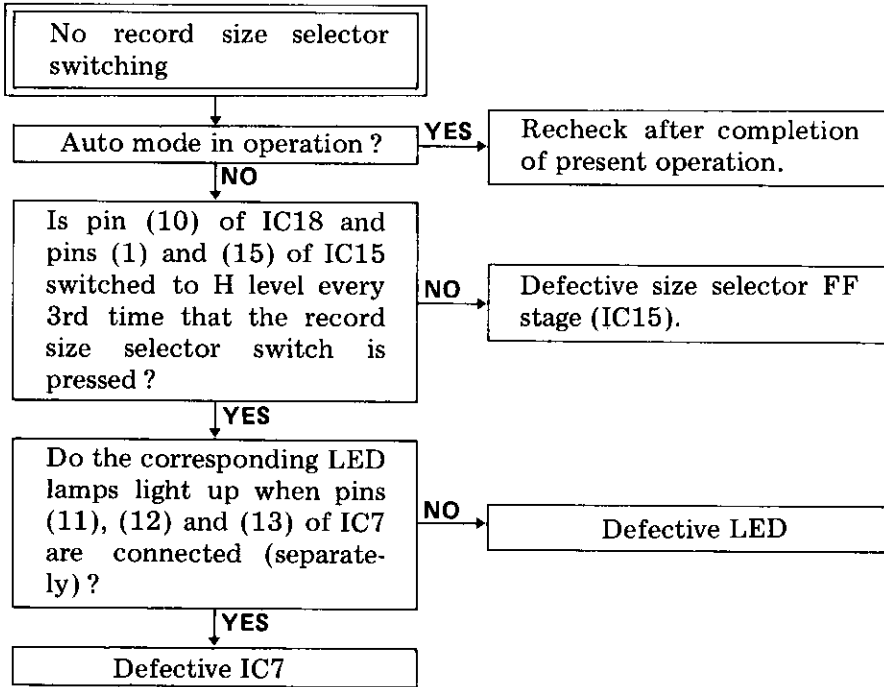

9.1.4

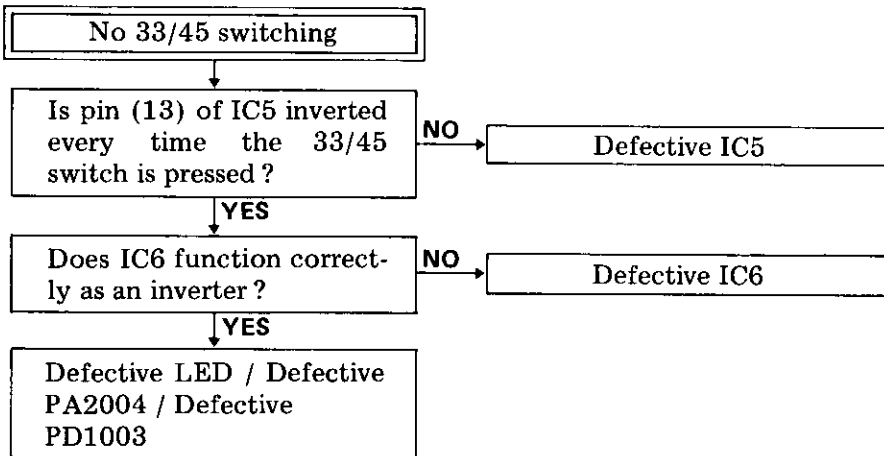

9.1.5

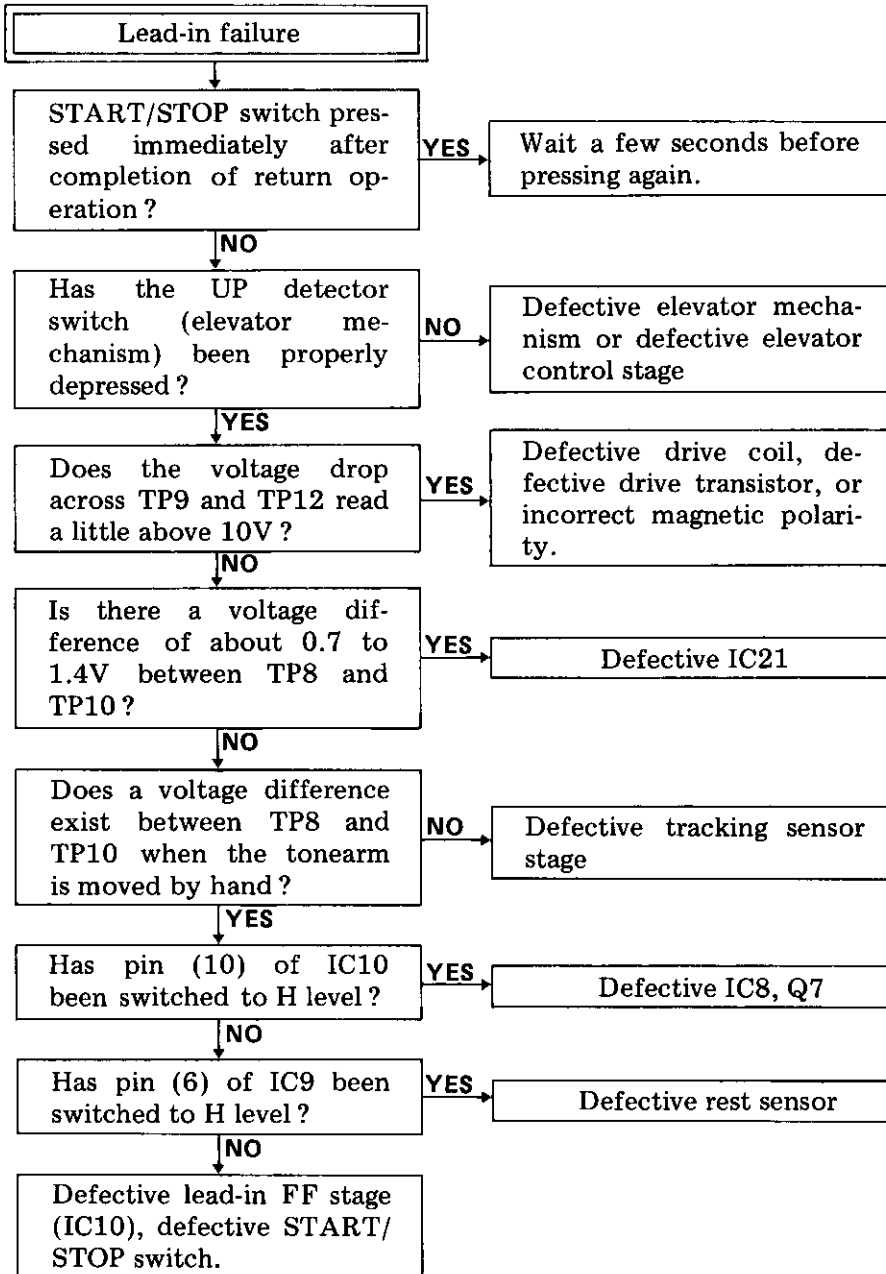

9.1.6

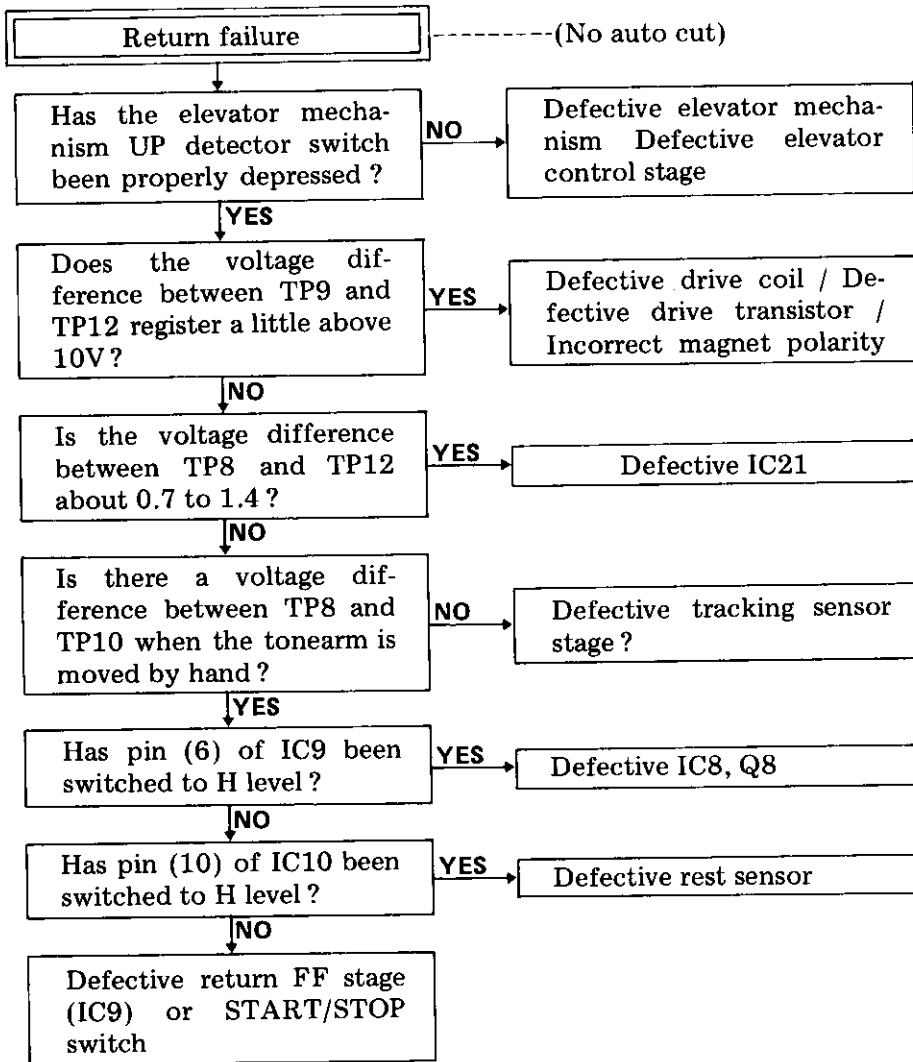

9.1.7

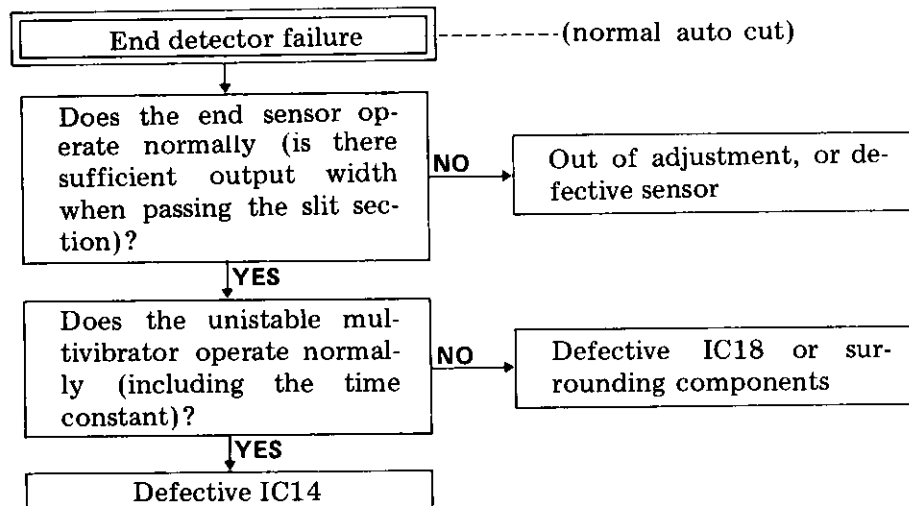

9.1.8

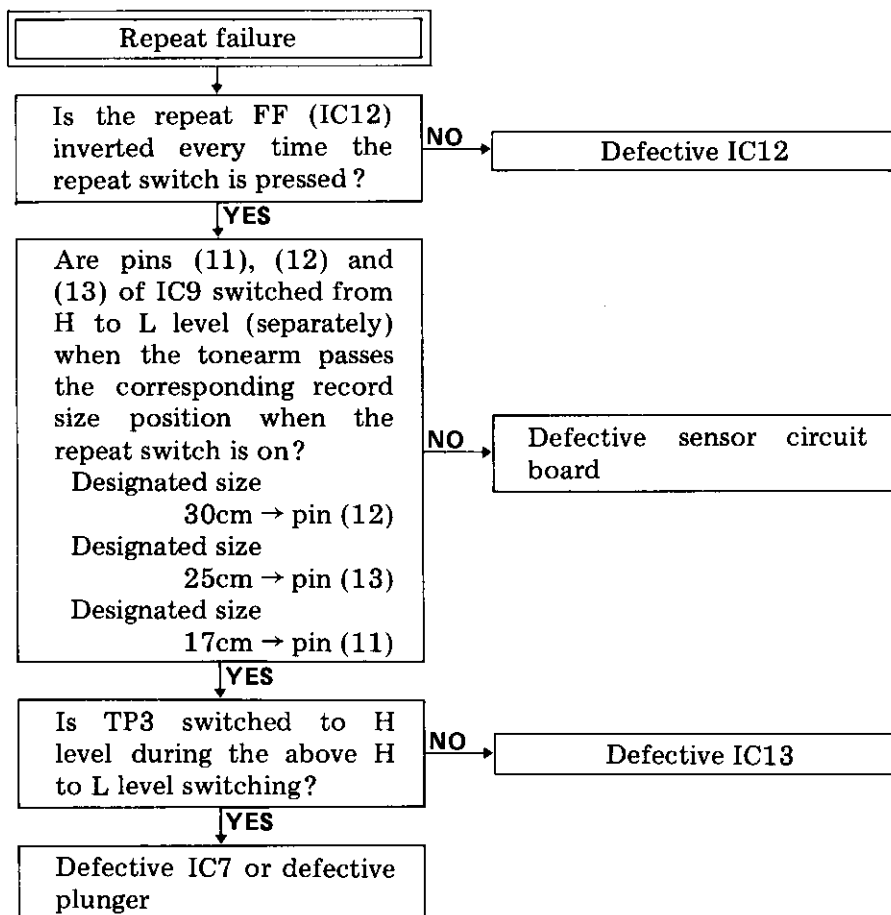

9.1.9

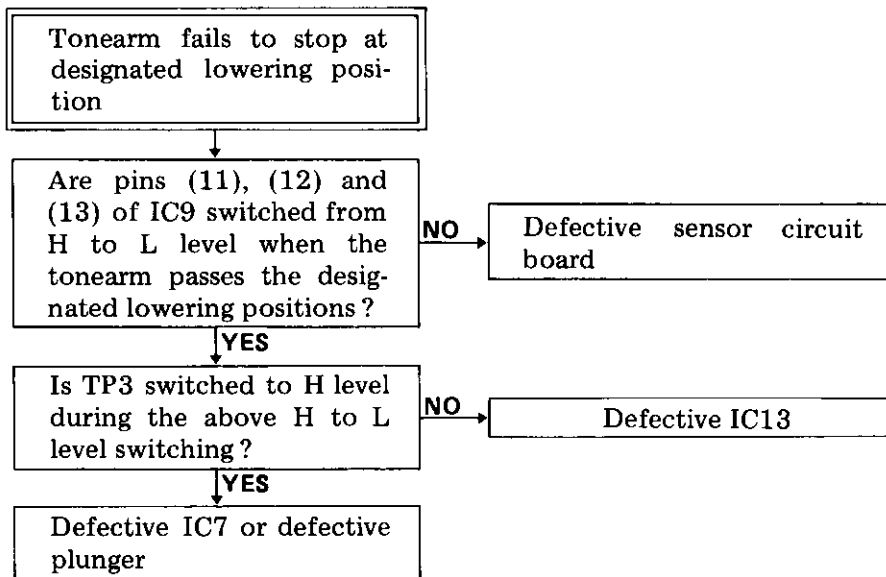

9.1.10

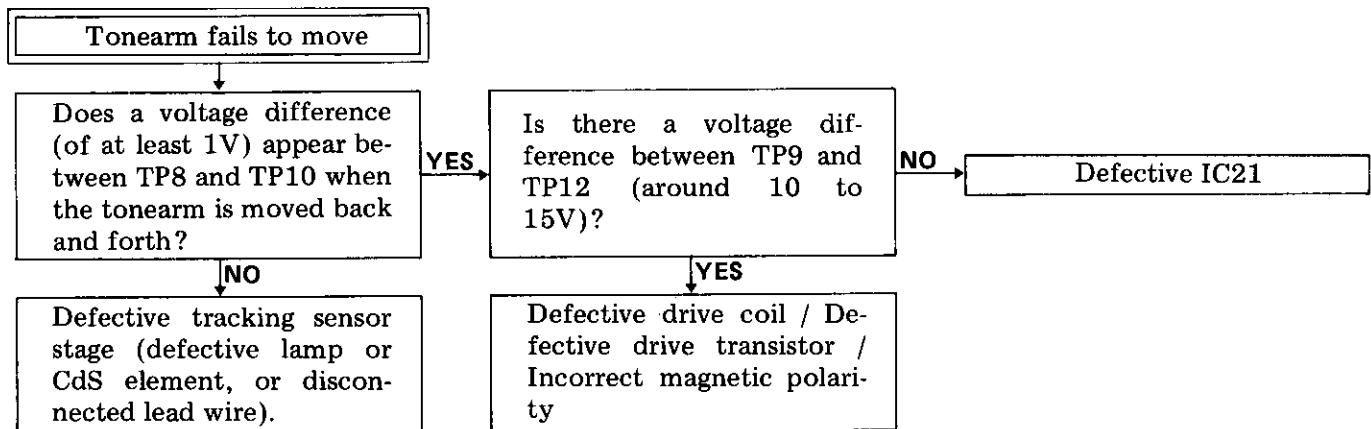

9.1.11

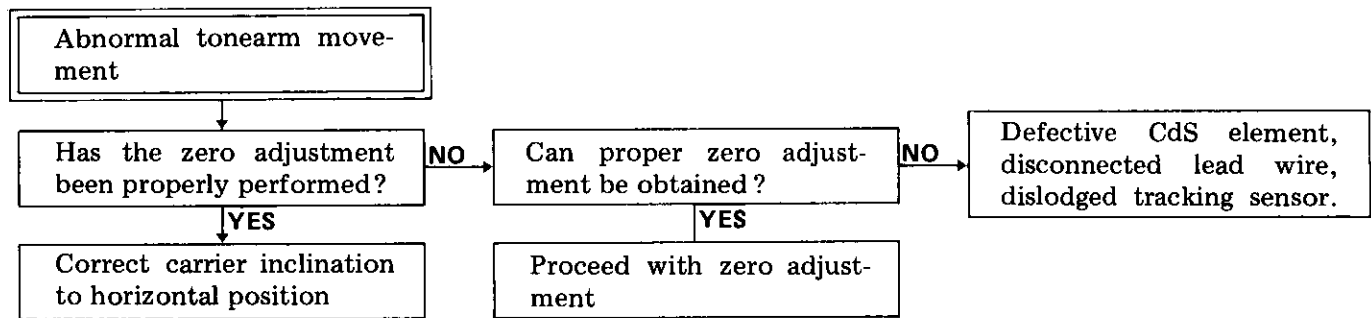

9.1.12

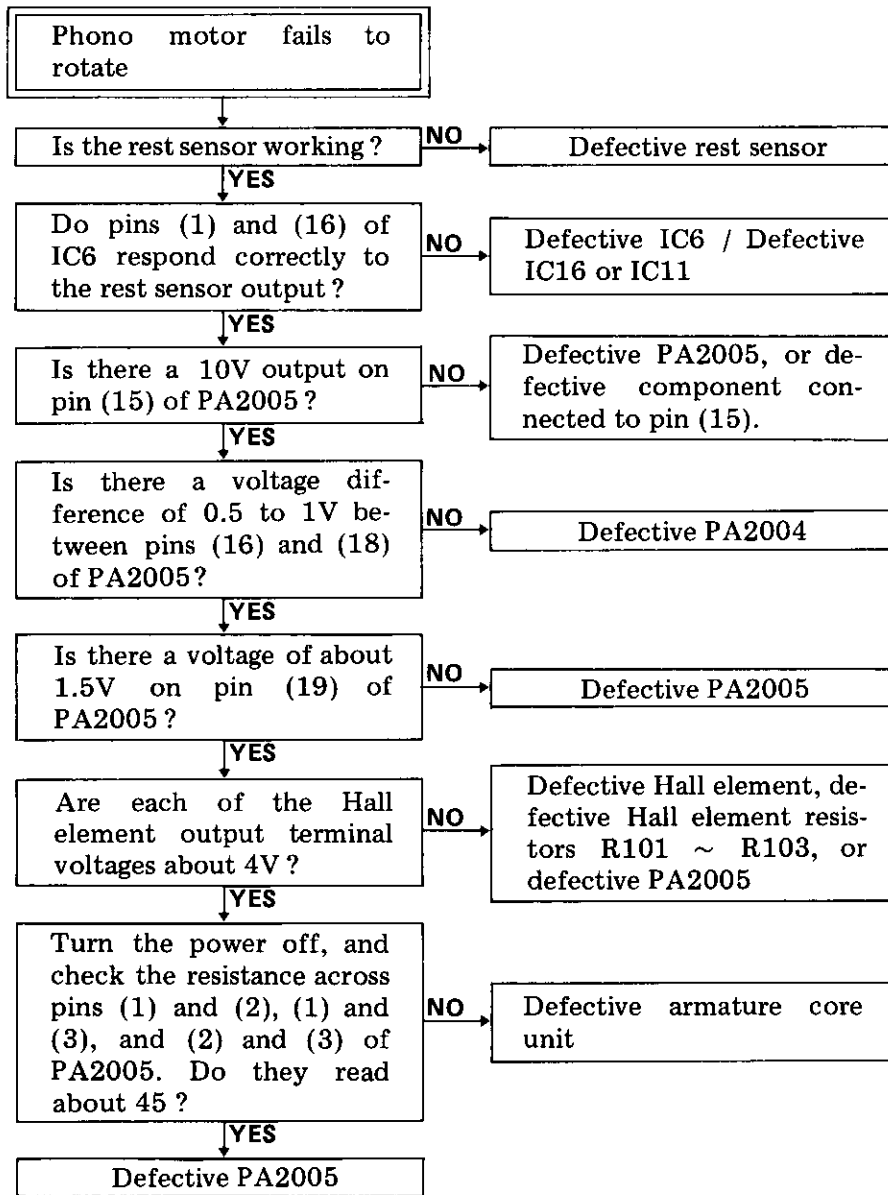

9.1.13

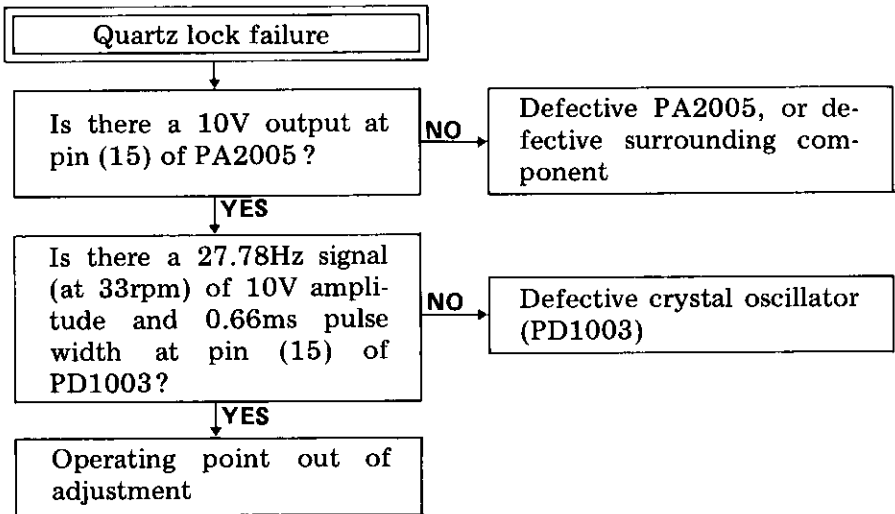

9.1.14

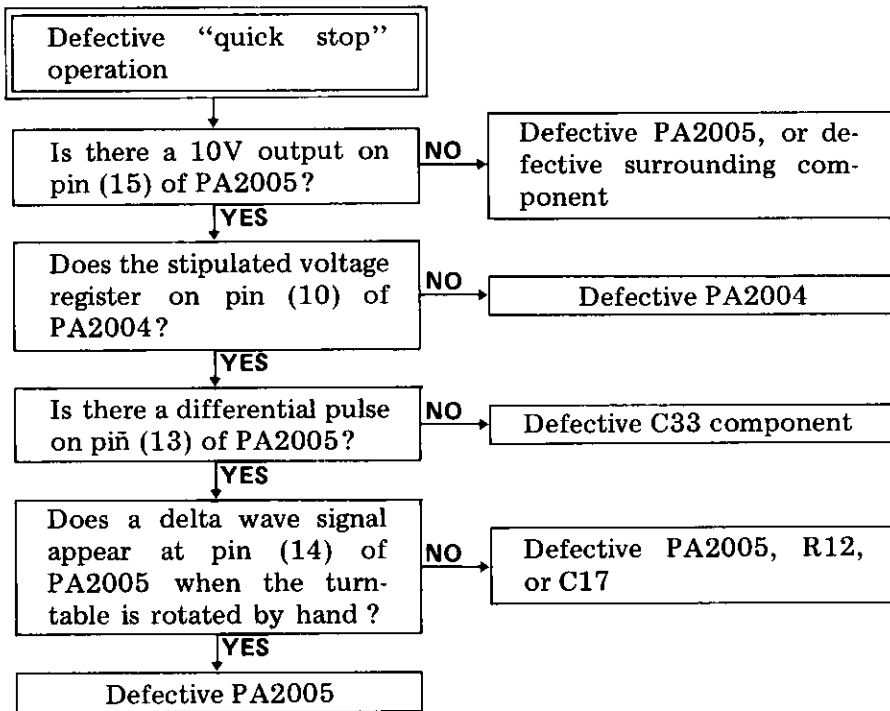

9.1.15

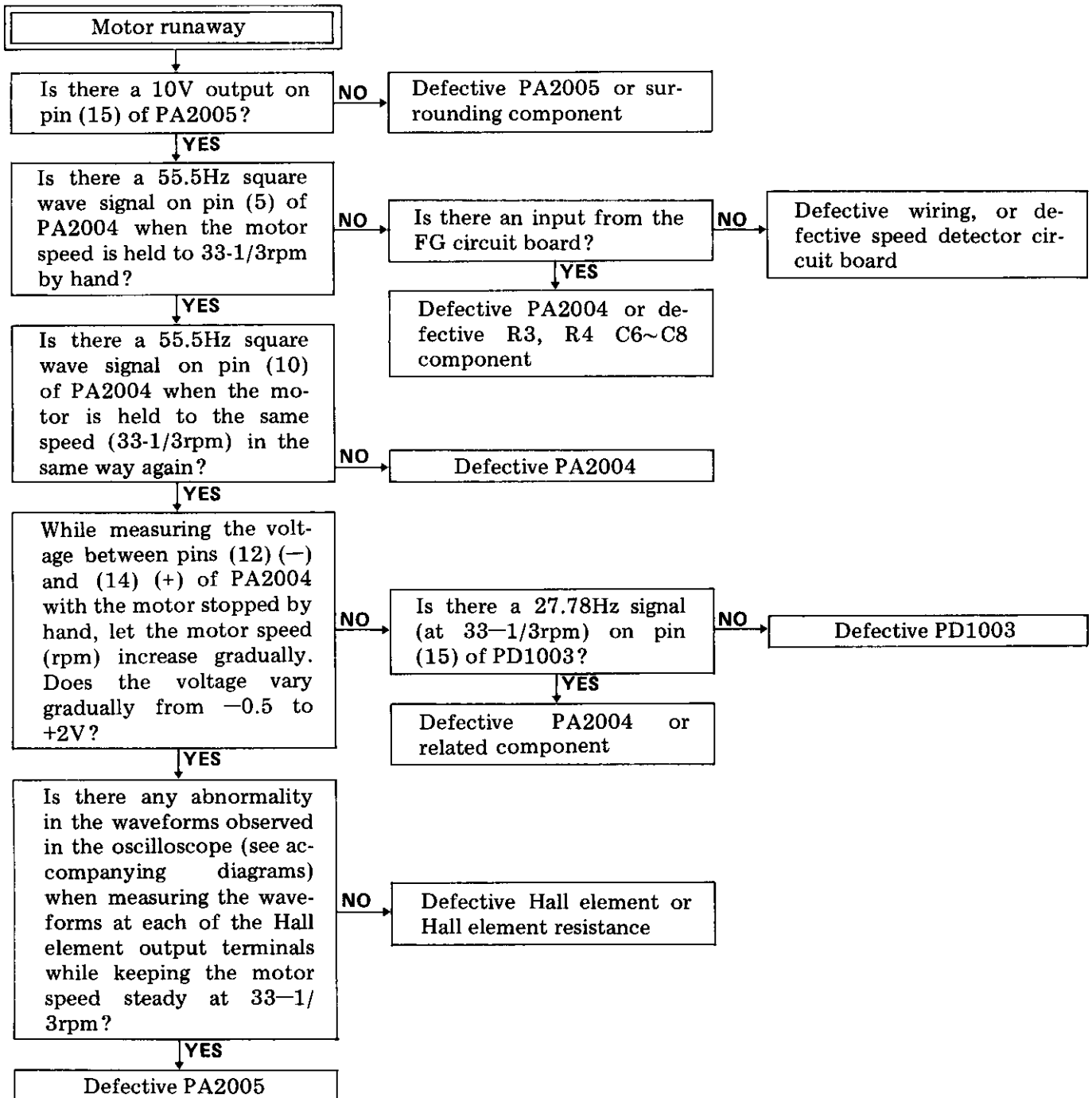

[Hall element output waveforms]

A. Normal waveform

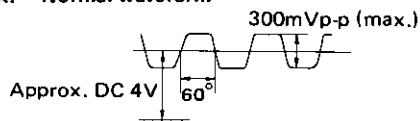

B. Low output waveform (AC output)

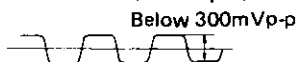

C. Examples of distorted waveform (but normal output level)

Ex. 1

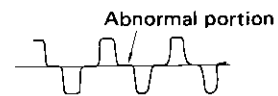

EX. 2

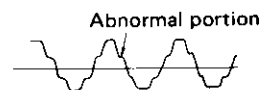

9.2 MECHANISM BLOCK

9.2.1

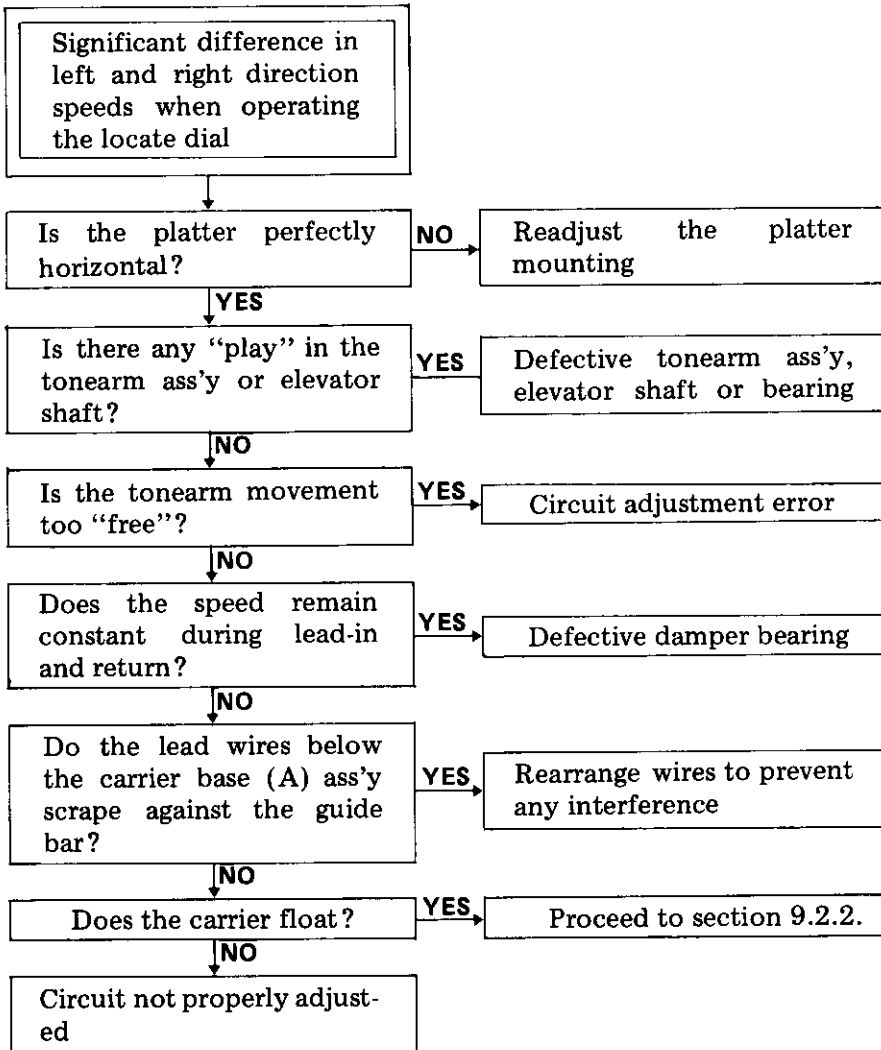

9.2.2

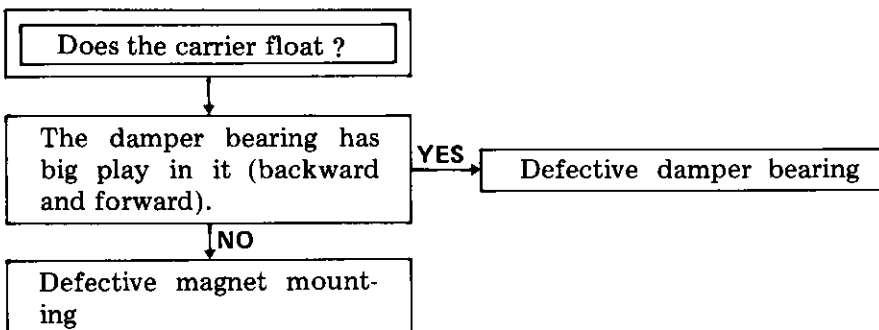

9.2.3

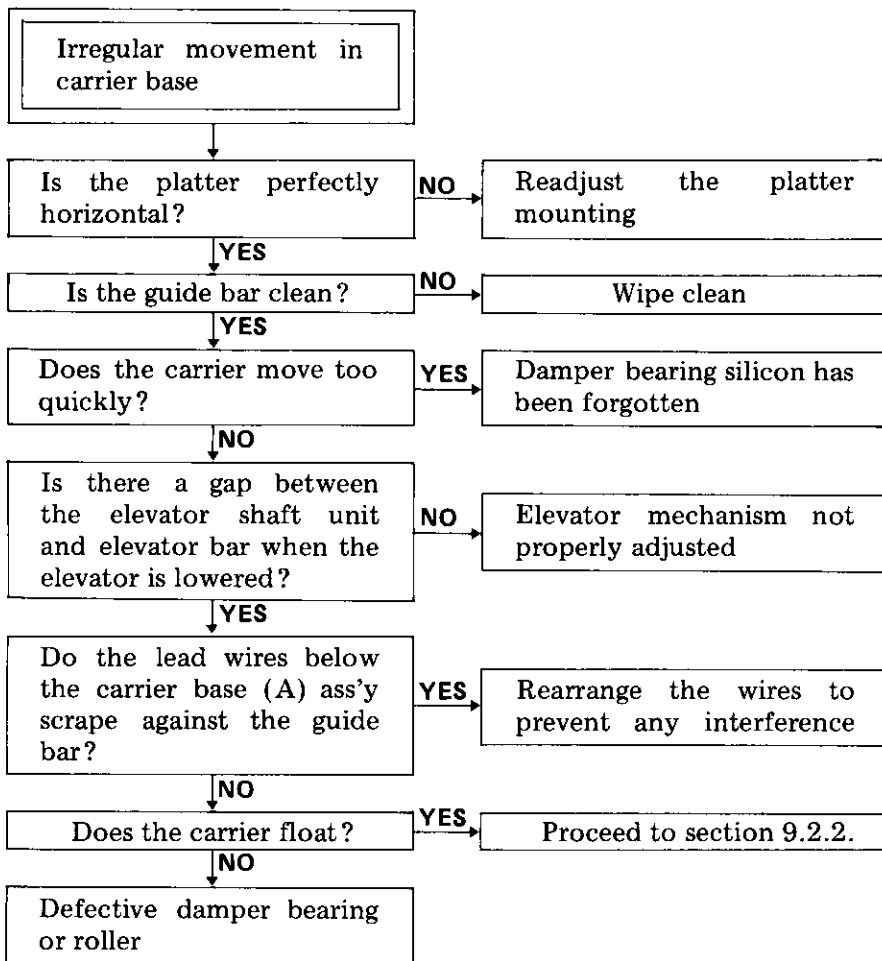

9.2.4

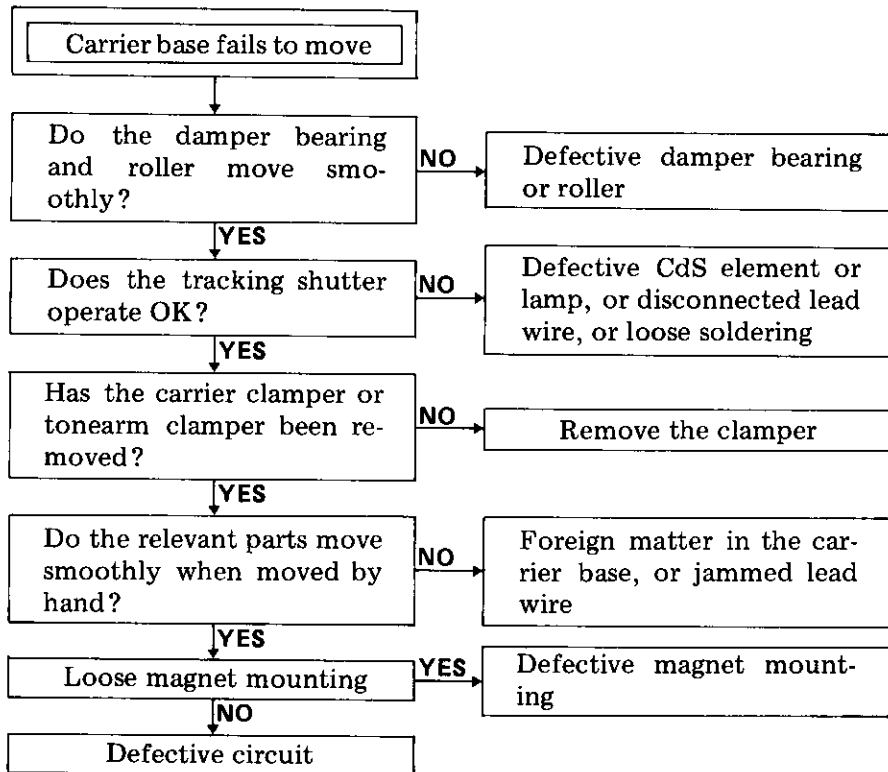

9.2.5

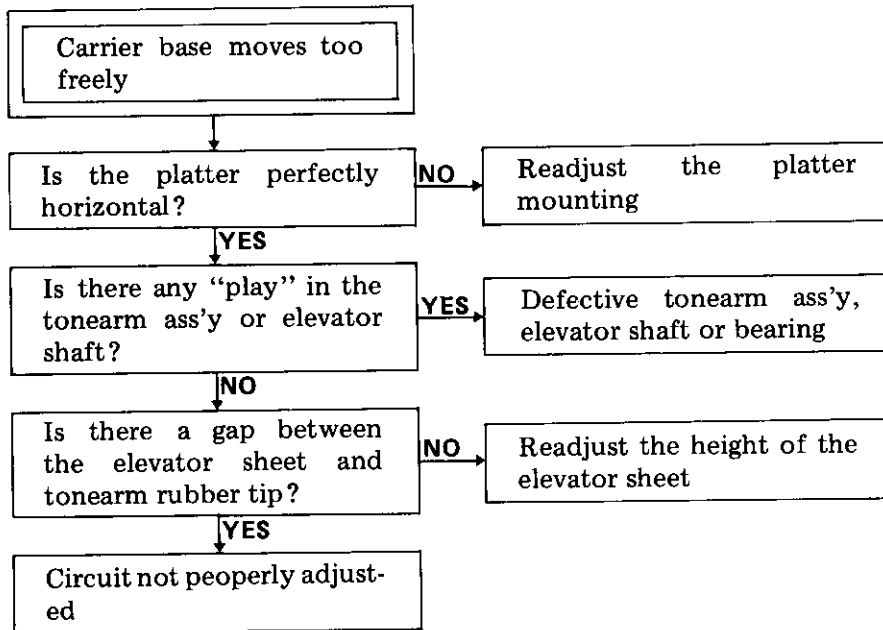

9.2.6

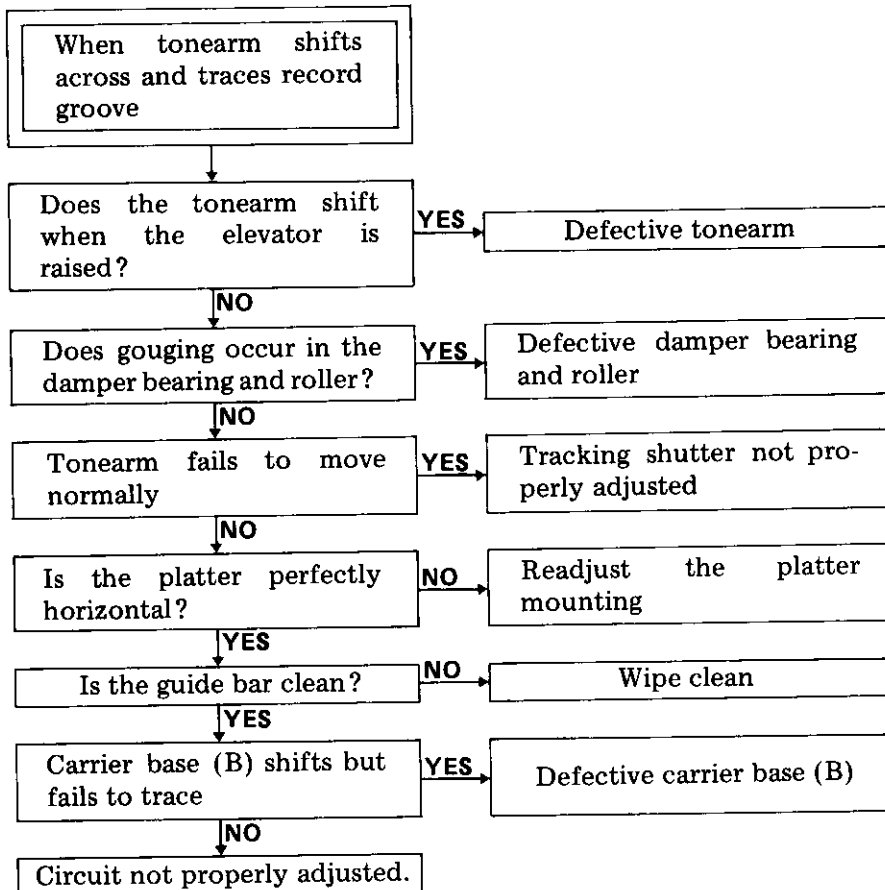

9.2.7

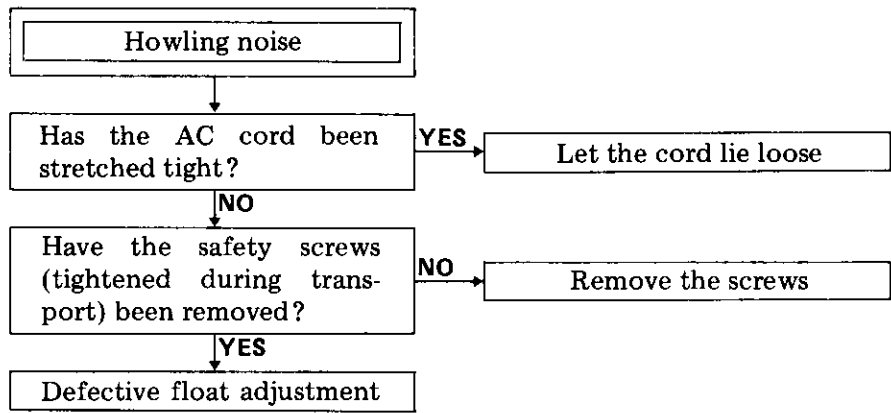

9.2.8

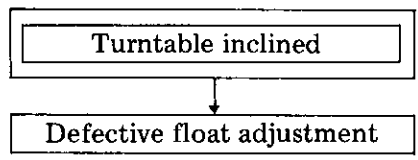

9.2.9

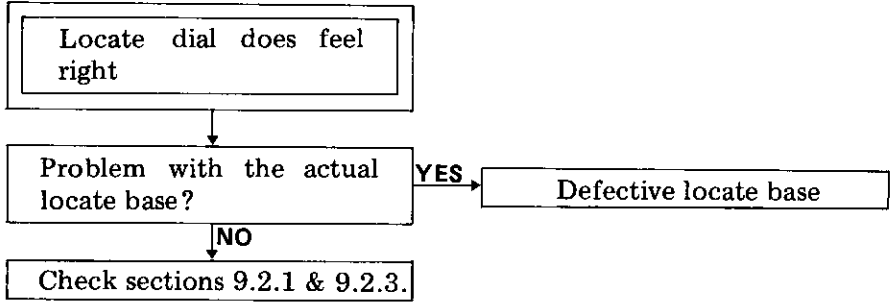

9.2.10

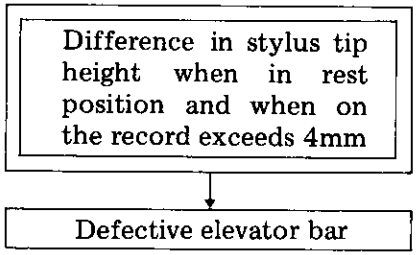

9.2.11

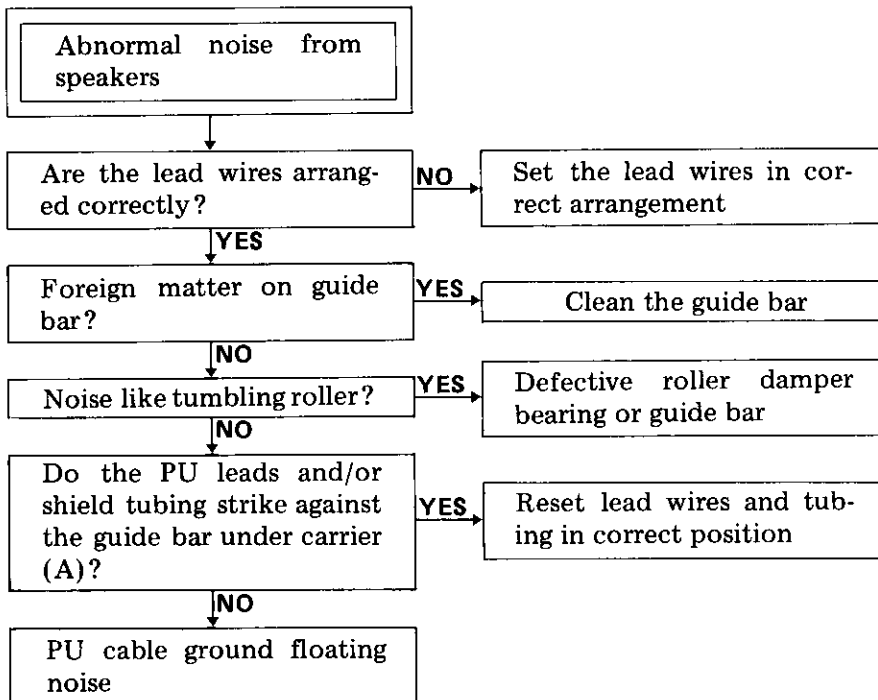

9.2.12

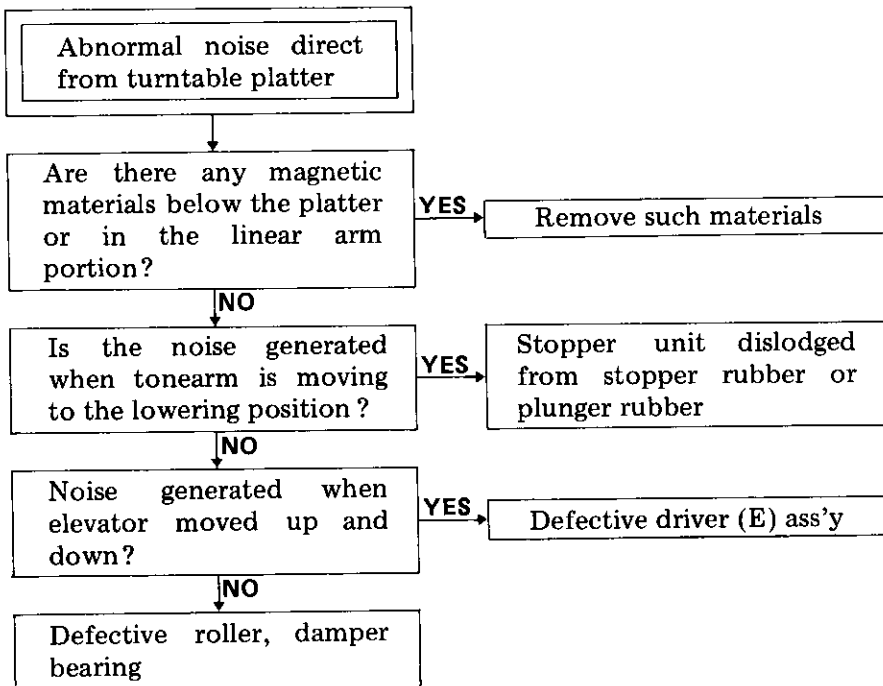

9.2.13

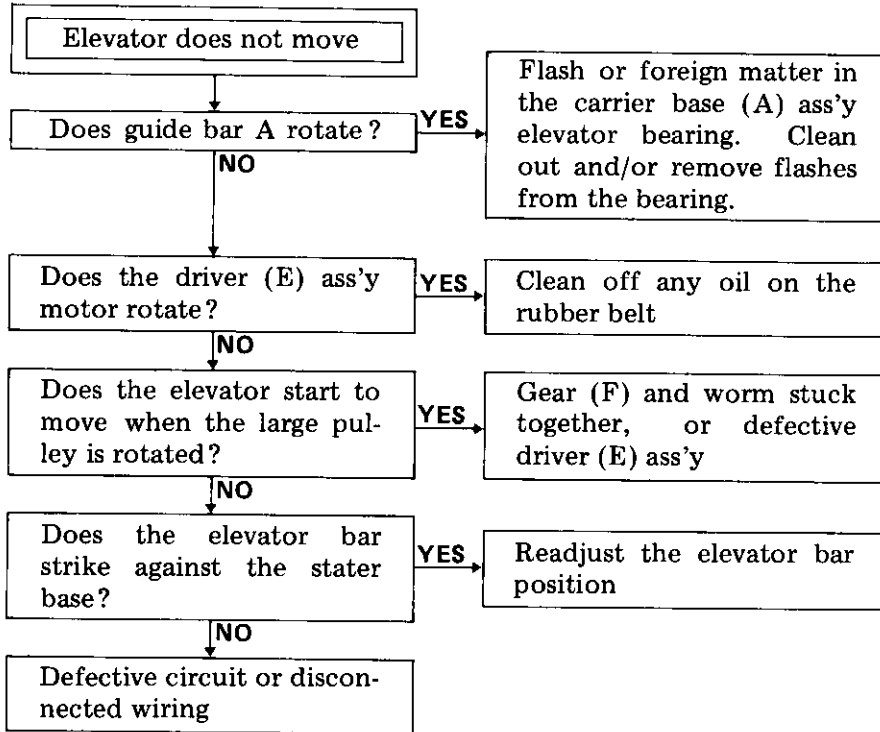

9.2.14

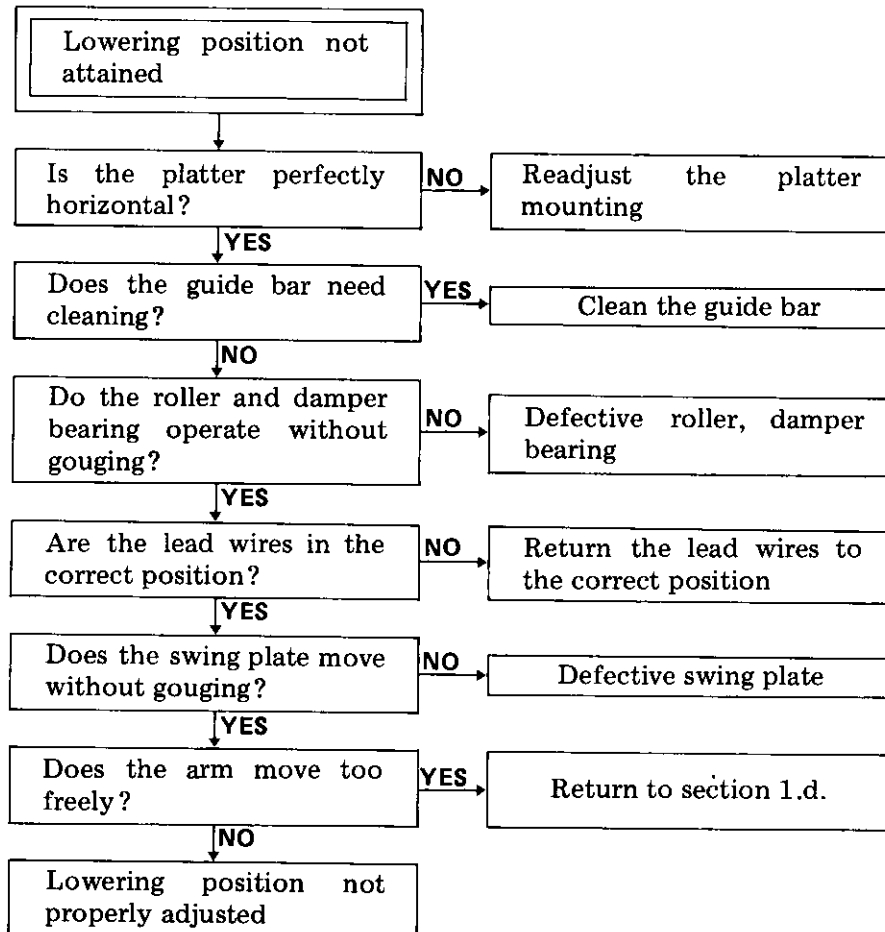

9.2.15

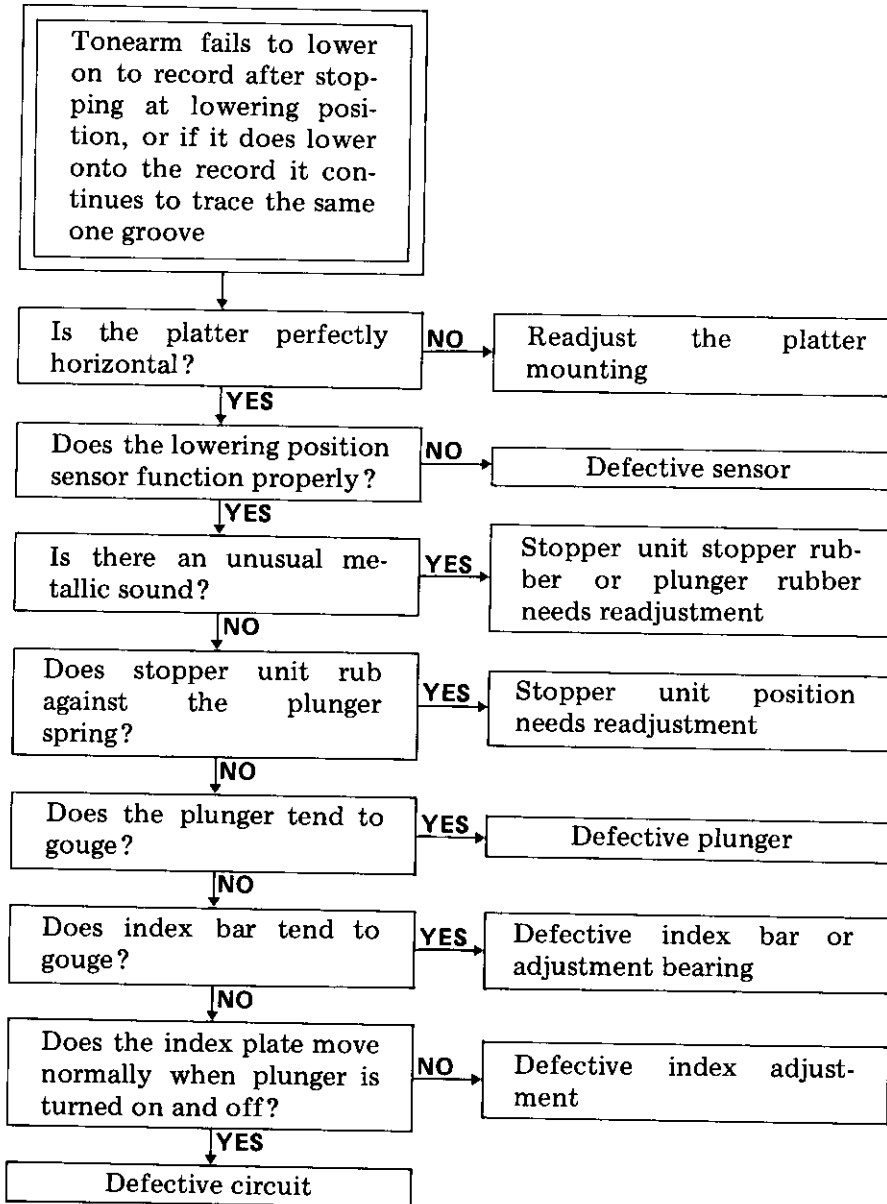

9.2.16

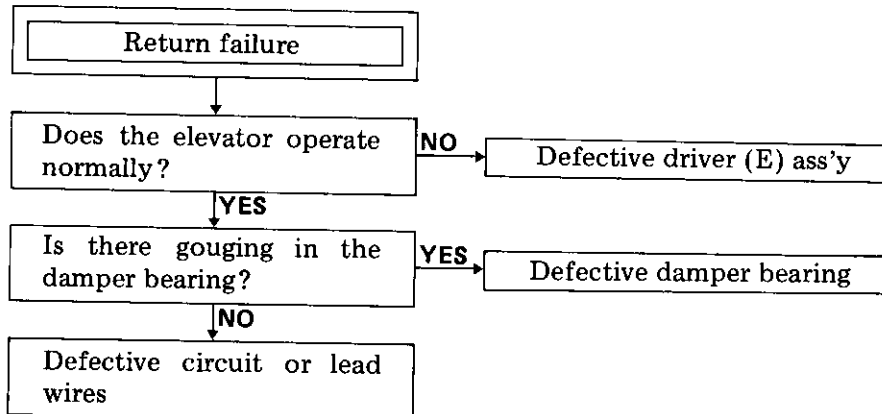

10. EXPLODED VIEWS

10.1 EXTERIOR

A

B

C

D

1

2

3

1

2

3

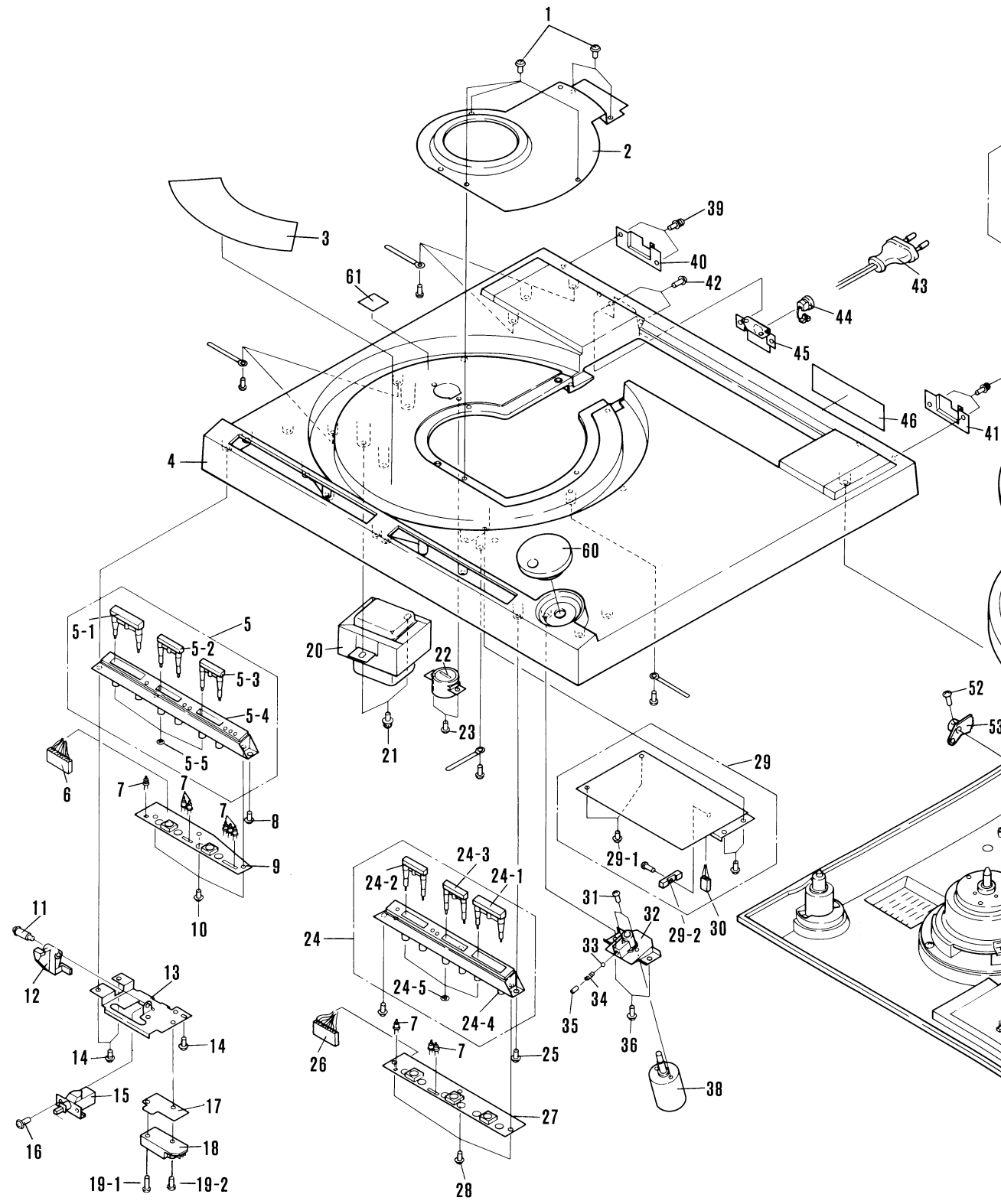

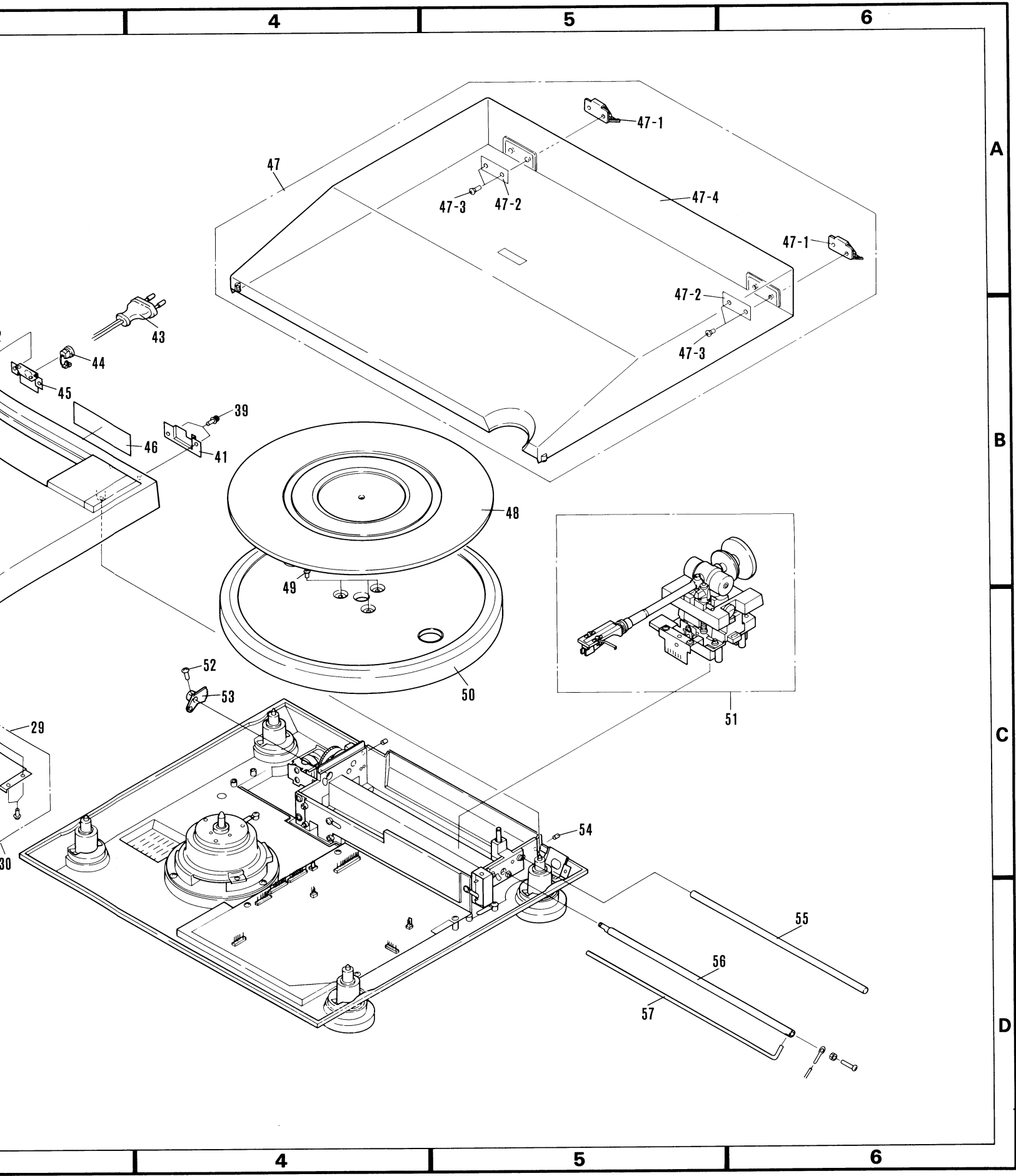

Parts List of Exterior

Key No.	Part No.	Description
1.		Washer faced alutite screw 3 x 8
2.		Cover
3.	PRW-068	Caution label
4.	PNR-126	Panel
5.		Control case assembly
5-1	PAD-058	Push button unit A
5-2	PAD-059	Push button unit E
5-3	PAD-060	Push button unit C
5-4	PNX-135	Control case A
5-5		CS type washer 2φ
6.	PDE-065	Connector assembly
7.	GL-2PR1	LED
8.		Washer faced alutite screw 3 x 8
9.		P.C. Board
10.		PT 3 x 8
11.	PBA-104	Screw
12.	PNX-092	Lever
13.		Switch base
14.		Washer faced alutite screw 3 x 8
15.	PSG-017	Push switch
16.		Washer feed alutite screw 3 x 6
△ 17.	PEC-052 (HET, HBT)	Insulator
△ 18.	PSF-012 (HET, HBT)	Microswitch
	PSF-008 (S/G)	"
19-1		PSA 3 x 15
19-2	(HET, HBT)	Plastic screw 3 x 15
	(S/G)	PSA 3 x 15
△ 20.	PTT-097 (HET, HBT)	Power transformer
	PTT-100 (S/G)	
21.		PSB 4 x 8
△ 22.	PSB-002 (HET, HBT)	Line voltage selector
	PSB-007 (S/G)	
23.		Washer faced alutite screw 3 x 8
24.		Control case B assembly
24-1	PAD-061	Push button unit B
24-2	PAD-062	Push button unit D
24-3	PAD-063	Push button unit F
24-4	PNX-130	Control case B
24-5		CS type washer 2φ
25.		Washer faced alutite screw 3 x 8
26.	PDE-071	Connector assembly
27.		P.C. Board
28.		PT3 x 8
△ 29.	PWR-057	Power supply assembly
	(HET, HBT)	
	PWR-058 (S/G)	
30.	PDE-067	Connector assembly
31.		PSA 2.6 x 6
32.	PNX-094	Base
33.	PEC-063	Nylon ball 3φ
34.	PBH-257	Spring
35.		SF 4 x 5
36.		Washer faced alutite screw 3 x 8

● The  mark found on some component parts indicates the importance of the safety factor of the part. Therefore, when replacing, be sure to use parts of identical designation.

● Parts without part number cannot be supplied.

Key No.	Part No.	Description
37.		Motor
38.	PXT-403	Washer faced alutite screw 3 x 8
39.		Plate L
40.	PNW-338	Plate R
41.	PNW-339	PSB 3 x 8
42.		AC power cord
△ 43.	PDG-021	(HET, HBT)
	PDG-004 (S/G)	
44.	PEC-051	Strain relief
	(HET, HBT)	
	E32-056 (S/G)	
45.		Angle
46.		Label
47.		Dust cover assembly
47-1	PXA-463	Hinge assembly
47-2	PNB-105	Plate
47-3		DCM 4 x 8
47-4	PNV-035	Dust cover
48.	PEA-036	Rubber mat assembly
49.	PXB-134	Screw
50.	PNR-121	Turntable platter assembly
51.		
52.		PM 3 x 5
53.	PNX-108	EV gear
54.		
55.	PLB-051	Guide bar B
56.	PLB-050	Guide bar A
57.	PLB-067	EV bar
58.		
59.		
60.	PXT-391	Dial unit
61.	PRW-046	Label

10.2 TONEARM

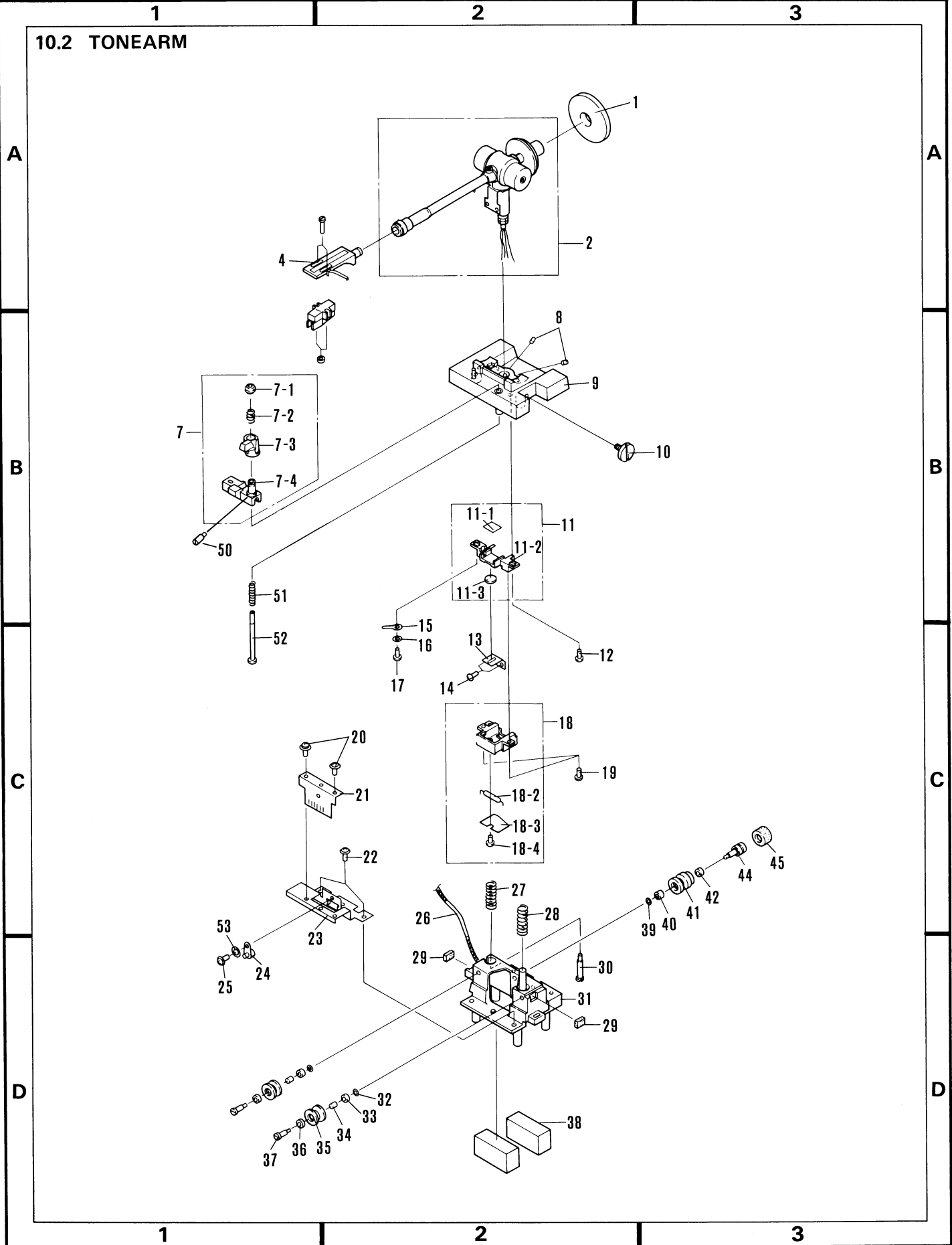

Parts List of Tonearm

• Parts without part number cannot be supplied.

Key No.	Part No.	Description	Key No.	Part No.	Description
1	PXA-804	Weight assembly	31.		Base B
2	PPD-601	Tone arm assembly	32.	PBE-017	Washer
3			33.	PXB-121	Bearing
4	Head shell assembly		34.	PNC-145	Spacer
5			35.	PLB-046	Roller
6.			36.	PXB-120	Bearing
7.	PXB-116	EV sheet assembly	37.	PLB-047	Shaft
7-1		Stopper	38.		Magnet
7-2		Spring	39.	PBE-017	Washer
7-3		Cramper	40.	PXB-120	Bearing
7-4		EV sheet unit	41.	PLB-059	Shaft holder A
8.		HS 3x5	42.	PXB-121	Bearing
9.	PNR-127	Base A	43.		
10.	PXT-414	Screw	44.	PXT-394	Shaft holder B unit
11.			45.	PEB-158	Rubber cap
11-1		Sensor board	46.		
11-2	PNX-103	Spacer	47.		
11-3	PCX-051	Cds	48.		
12.		PM 2.6 x 6	49.		
13.		Tracking shater	50.	PAD-064	EV adjust screw
14.		PM 2.6 x 5	51.	PBH-255	EV spring
15.		Terminal	52.		EV shaft
16.		FW 2.6 x 5 x 0.5t	53.		Plastic washer 4φ x 0.13t
17.		PM 2.6 x 6			
18.					
18-1.	PNX-102	Cupler base			
18-2.	PEL-041	Lamp			
18-3		Sensor board			
18-4		PT 2.6 x 8			
19.		PT 2.6 x 8			
20.		PSA 3x5			
21.		Shutter			
22.		Washer faced alutite screw 3 x 6			
23.		Plate			
24.		Pin unit			
25.	PBA-094	Screw			
26.	PDA-013	Shield tube			
27.	PBH-254	Spring			
28.	PBH-254	Spring			
29.	PEB-171	Rubber pad			
30.	PLB-060	Screw			

10.3 EV MECHANISM

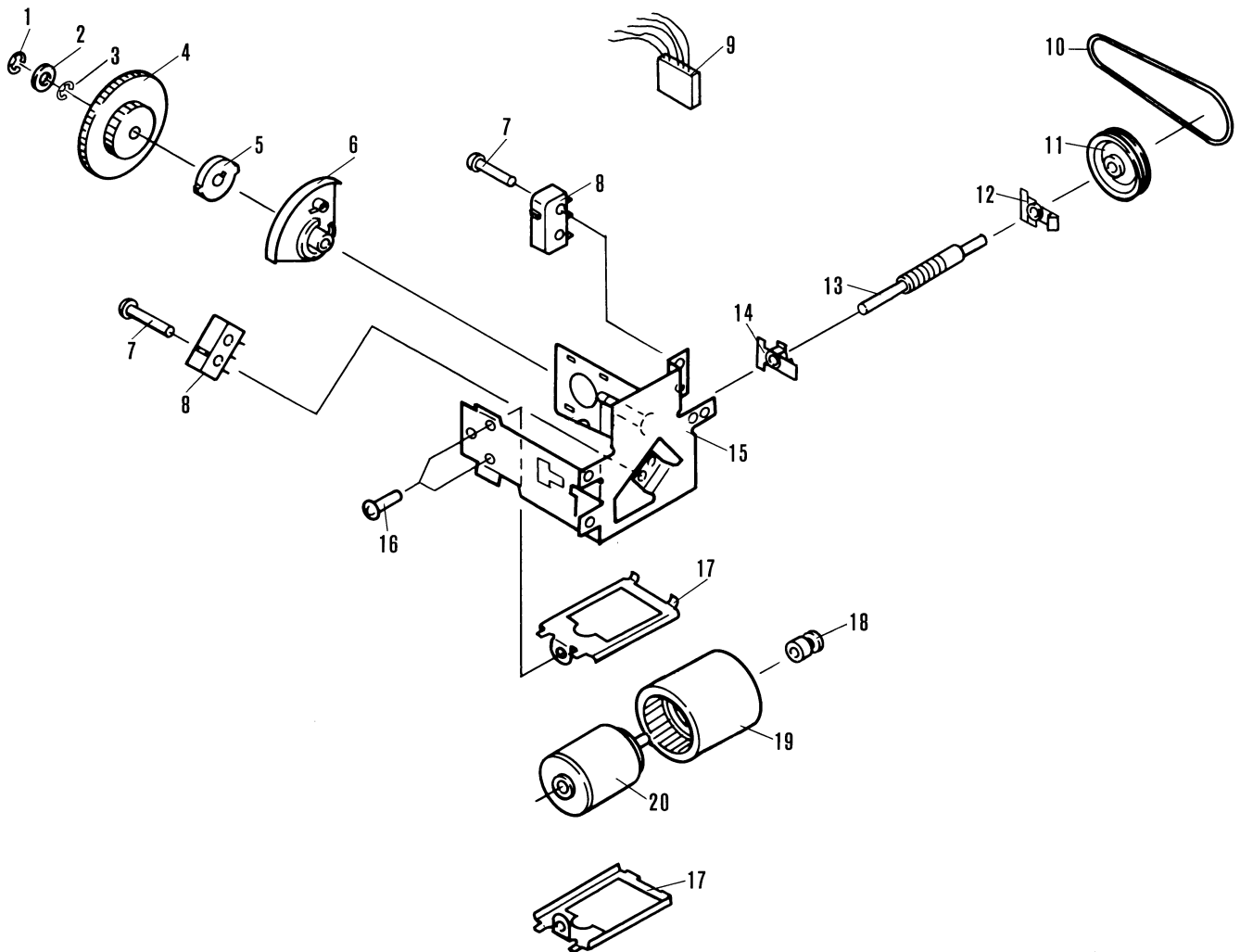

Parts List

• Parts without part number cannot be supplied.

Key No.	Part No.	Description	Key No.	Part No.	Description
1.		EW3	11	PNW-393	Pulley
2.	PBE-018	Washer	12	PNW-391	Collar
3.	PBE-014	Washer	13	PNW-485	Worm gear
4.	PNW-418	Gear F	14	PNW-391	Collar
5.		Plate	15		Chassis
6.	PNW-390	Cam	16.		PSA 2.6x5
7.		PT 2x10	17		Frame
8	PSF-005	Microswitch	18	PNW-392	Motor pulley
9	PDE-068	Connector assembly	19	PEB-167	Tube
10	PEB-097	Belt	20	PXM-073	Motor

1

2

3

10.4 BOTTOM PLATE

A

B

C

D

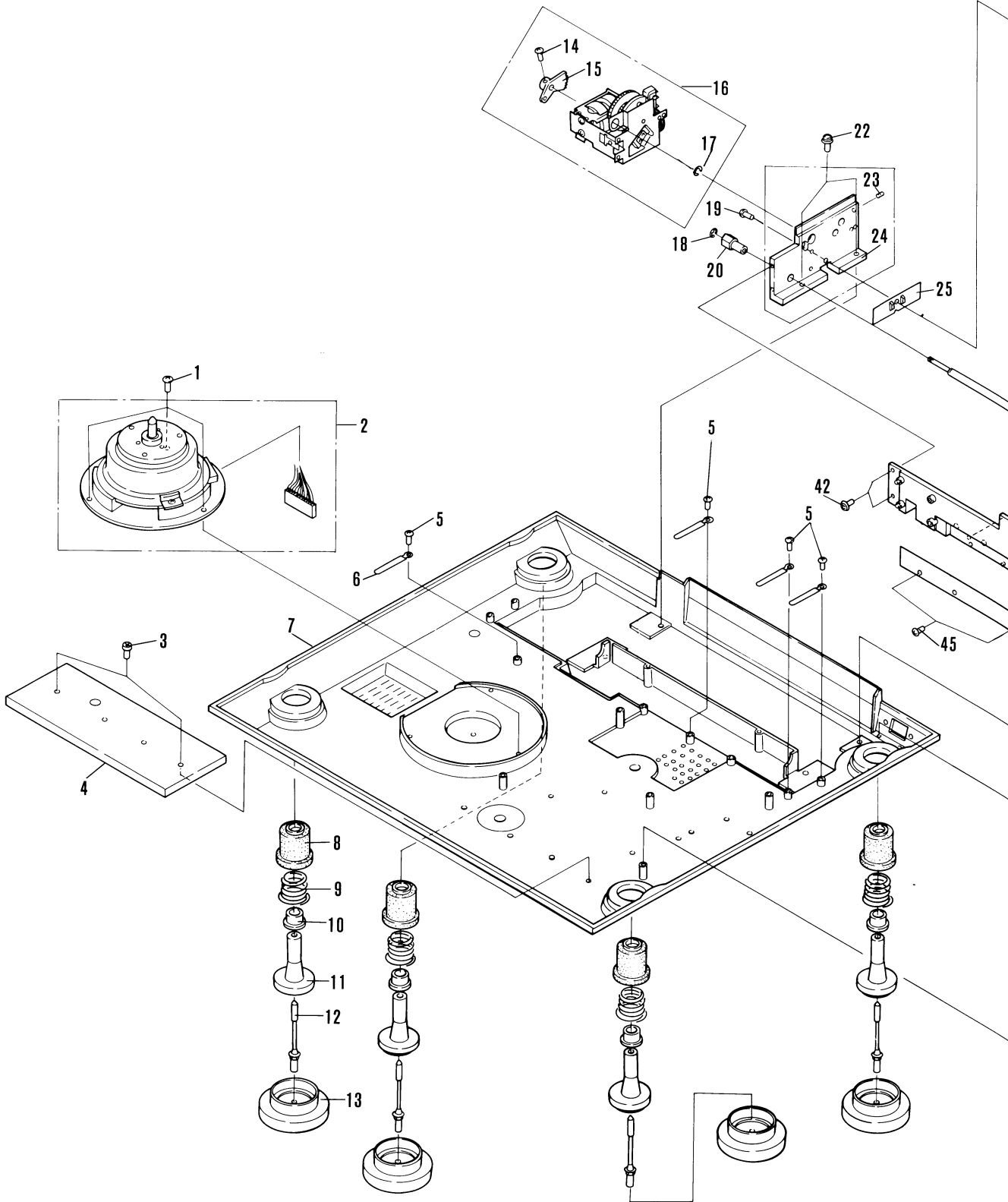

1

2

3

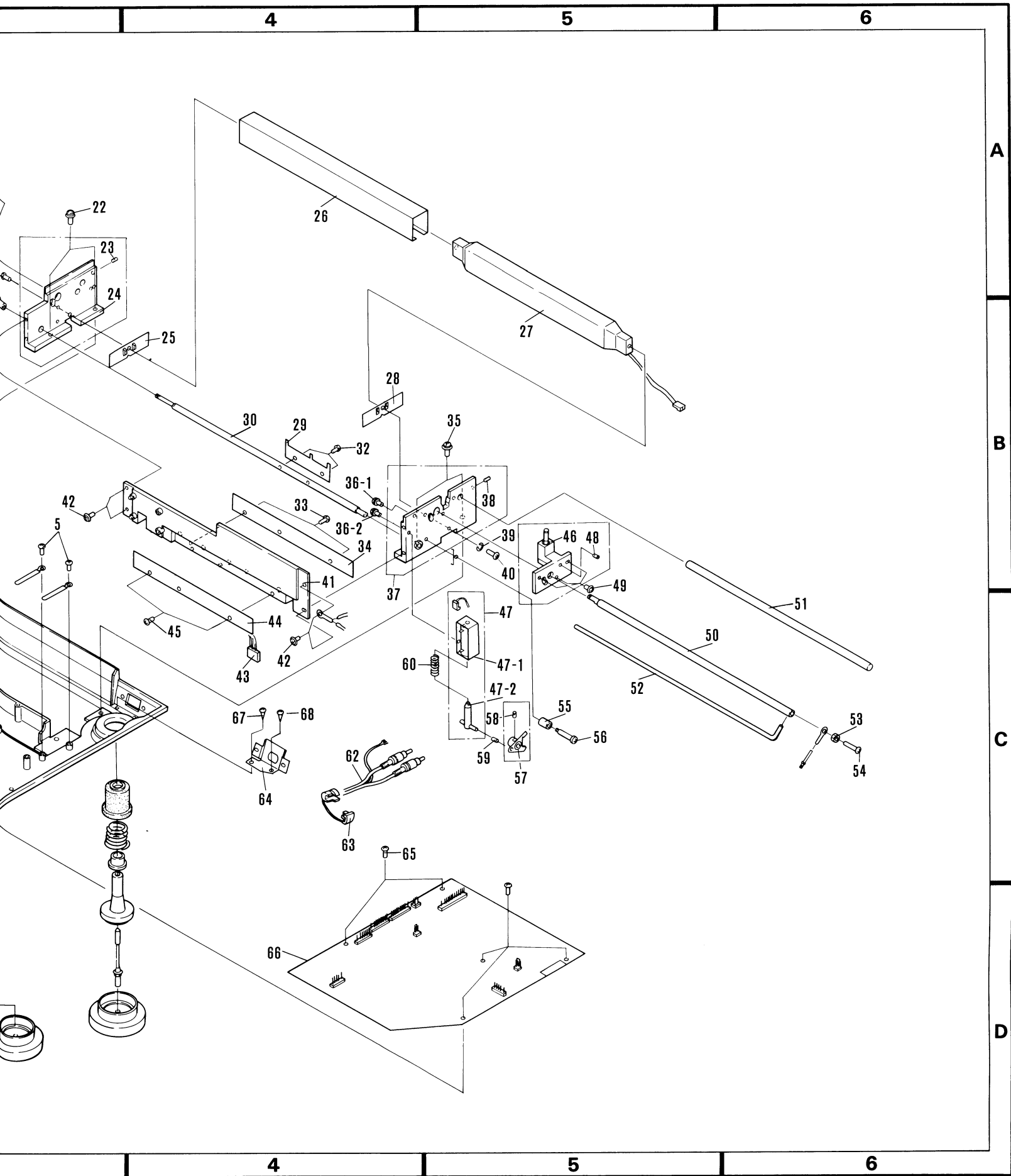

Parts List of Bottom Plate

● *Parts without part number cannot be supplied.*

Key No.	Part No.	Description	Key No.	Part No.	Description
1.		PSA 4 x 16	41.		Case
2.	PXB-061	Motor assembly	42.		Washer faced alutite screw 3 x 8
3.		PSB 4 x 16	43.	PDE-066	Connector assembly
4.		Balance weight	44.		Sensor board
5.		PT 3 x 12	45.		PT 3 x 8
6.		Cord clamper	46.	PXB-119	Cramper assembly
7.		Under base	47.	PXP-003	Solenoid assembly
8.	PEB-102	Rubber cushion A	48.		SF 3 x 5
9.	PBH-169	Spring C	49.		Washer faced alutite screw 3 x 6
10.	PNW-375	Spring holder	50.	PLB-050	Guide bar A
11.	PNW-483	Case C	51.	PLB-051	Guide bar B
12.	PBA-105	Screw	52.	PLB-067	EV bar
13.	PXT-392	Case unit	53.		N 3
14.		PM3x5	54.		PM 3 x 12
15.	PNX-108	EV gear	55.	PEB-155	Stopper cushion
16.		EV mechanism assembly	56.	PBA-107	Screw
17.		Ew 6	57.		Stopper unit
18.		Ew 3	58.		HF 3 x 3
19.		PSB 4 x 16	59.	PEB-170	Tube
20.		Adjust shaft holder	60.	PBH-252	Spring
21.			61.		
22.		PSB 4 x 12	62.	PDE-074	Output cord
23.		SF 3 x 5	63.	PEC-051	Strain relief
24.		Base B	64.		Angle
25.		Plate	65.		PT 3 x 12
26.		Coil cover	66.	PWM-032	Control assembly
27.	PXB-118	Coil assembly	67.		PT 3 x 12
28.		Plate	68.		PT 3 x 8
29.		Plate	69.		
30.		Bar	70.		
31.					
32.		PSF 3 x 6			
33.		PT 3 x 8			
34.		Sensor board			
35.		PSB 4 x 12			
36-1		PM 2.6 x 6			
36-2		PM 2.6 x 8			
37.		Base A			
38.		SF 3 x 5			
39.					
40.		PSB 4 x 16			

11. PACKING

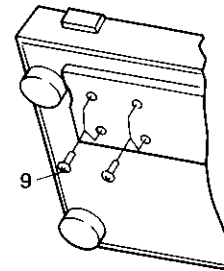
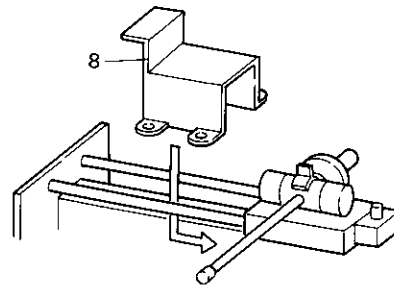
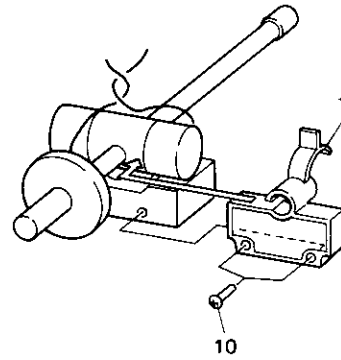
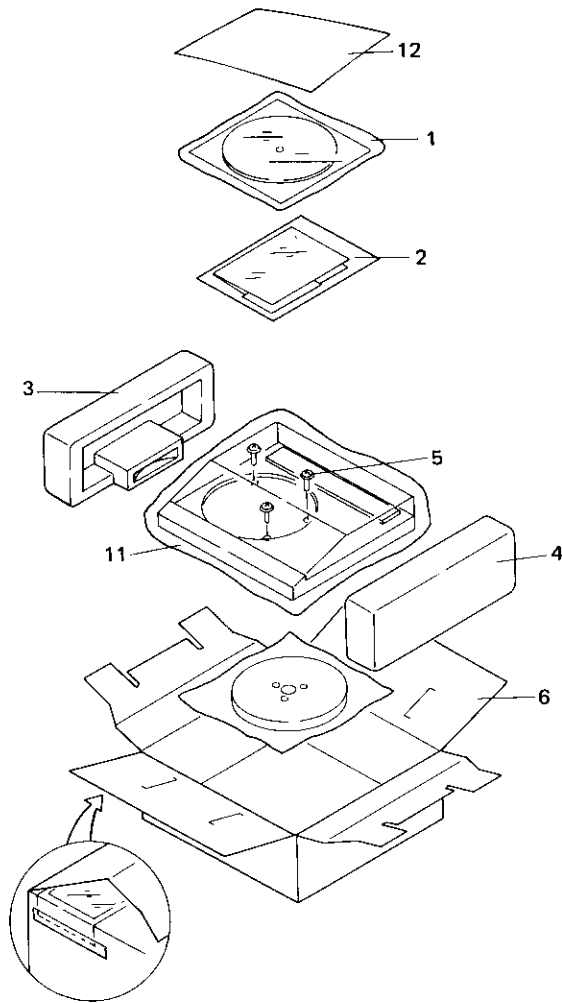

Parts List

Key No.	Part No.	Symbol & Description
1	PEA-036	Rubber mat assembly
2	PRB-156	Operating instructions (English)
	PRD-051 (HET, HBT)	Operating instructions (German/French)
3	PHA-109	Protector L
4	PHA-110	Protector R
5	PBA-079	Screw
	B22-026	Washer
6	PHG-408 (HET)	Packing case
	PHG-382 (S/G)	Packing case
7	PNX-098	Arm holder
8	PNX-097	Spacer
9		Screw PSB4x12
10		Screw PSB3x15
11	PHL-006	Cover
12	PHC-049	Upper protector
	PHN-008 (HET)	Headshell case
	PHN-009 (HET)	Headshell case cover

Accessories

Key No.	Part No.	Symbol & Description
	PXA-804	Weight assembly
	KEX-002	Screwdriver
	N93-603	EP Adapter
	PXB-125	Cartridge mounting part assembly
	PEC-012	Overhang gauge
	PAW-007	Level
	PED-016	Cleaning cloth

12. SCHEMATIC DIAGRAM (HET, HBT MODEL)

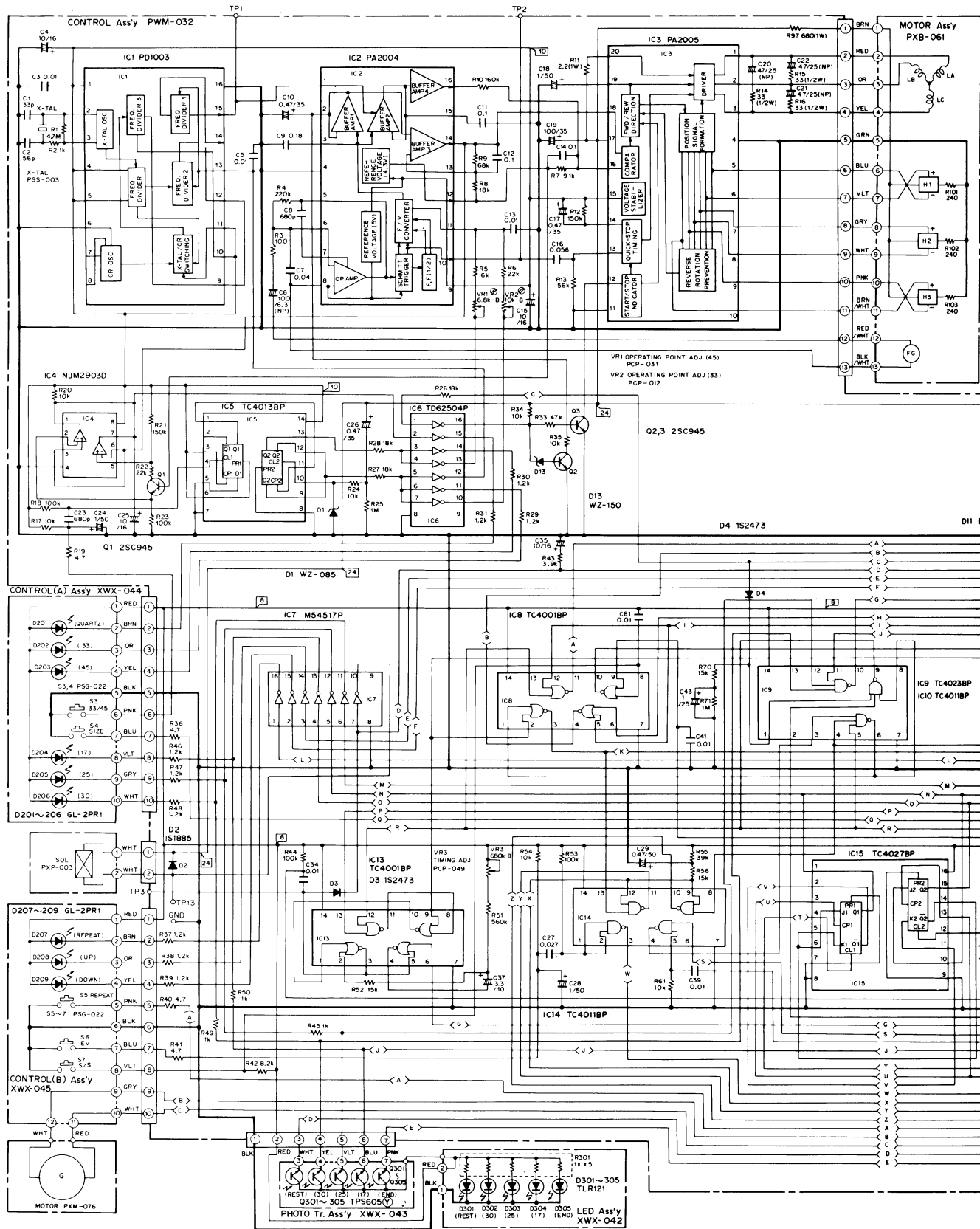

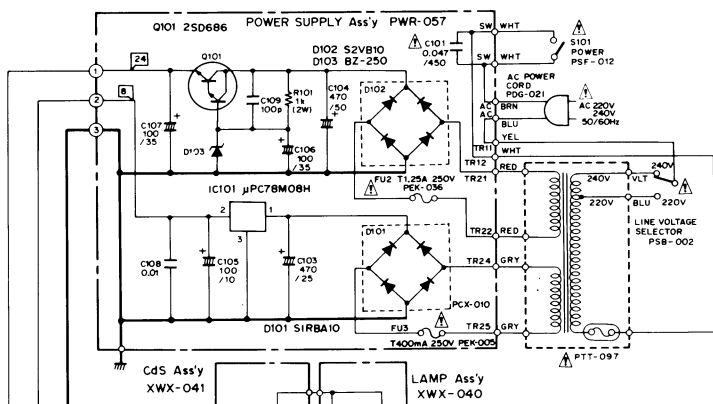
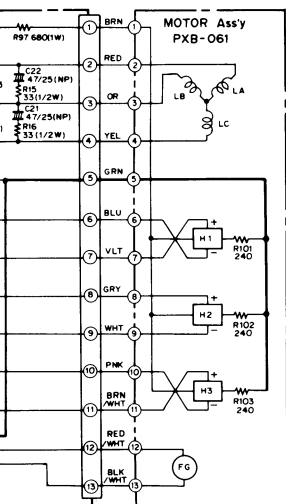

- RESISTORS:**
Indicated in Ω , $\frac{1}{2}W$, $\pm 5\%$ tolerance unless otherwise noted k : k Ω , M : M Ω , (F) : $\pm 1\%$, (G) : $\pm 2\%$, (K) : $\pm 10\%$ tolerance
- CAPACITORS:**
Indicated in capacity (μF)/voltage (V) unless otherwise noted p : pF Indicated without voltage is 50V except electrolytic capacitor.
- VOLTAGE**
□ : DC voltage (V) at no input signal
- OTHERS:**
⊗ : Adjusting point.
The Δ mark found on some component parts indicates the importance of the safety factor of the part. Therefore, when replacing, be sure to use parts of identical designation.

- SWITCHES:**
S1 : UP DETECTOR
S2 : DOWN DETECTOR
S3 : SPEED
S4 : SIZE
S5 : REPEAT
S6 : ARM-ELEVATION
S7 : START/STOP
S10 : POWER

The underlined indicates the due to improvements in design.

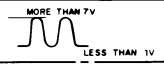
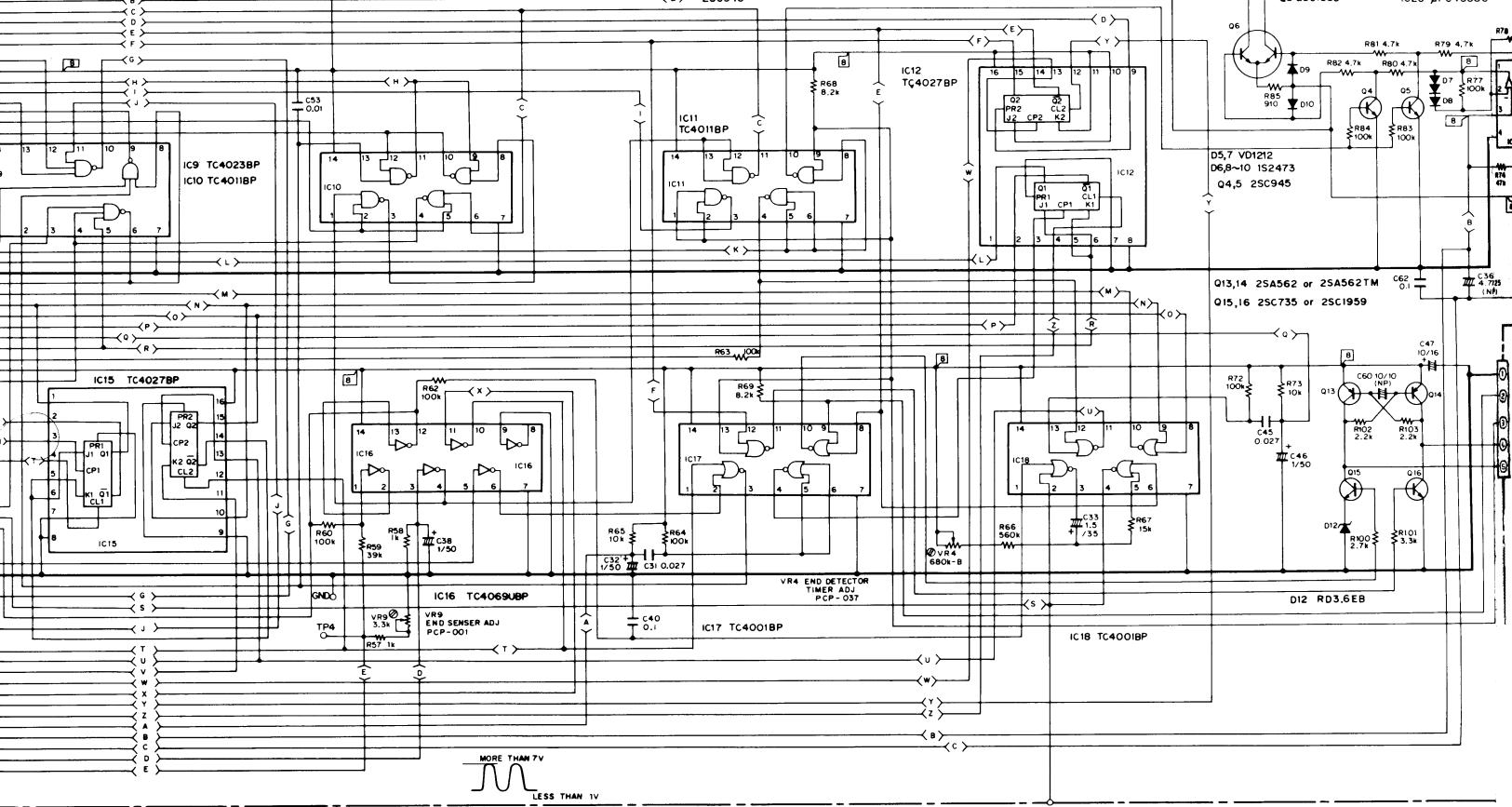
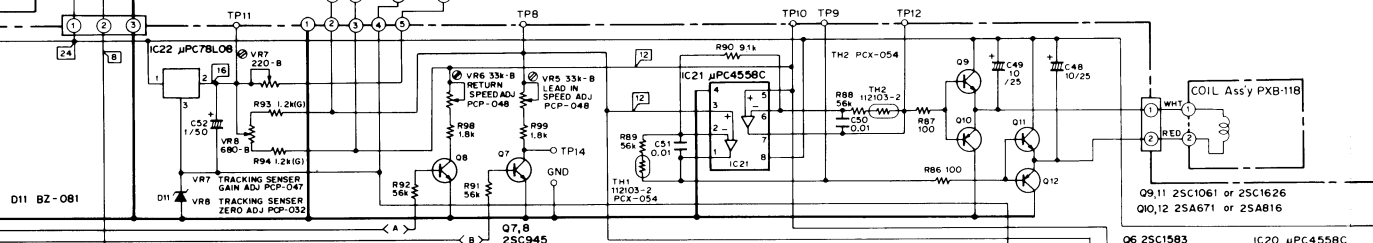

7

8

9

External Appearance of Transistors and ICs

2SA562TM
2SC945
2SC1815
2SC1959

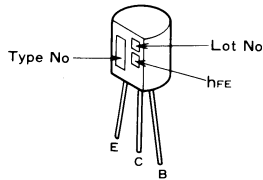

PA2004
PD1003
TD62504P
TC4027BP
M54517P

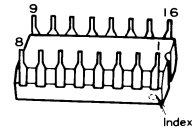

A

SWITCHES:
S1: UP DETECTOR ON — OFF
S2: DOWN DETECTOR ON — OFF
S3: SPEED 33 rpm — 45 rpm
S4: SIZE 17 — 25 — 30
S5: REPEAT ON — OFF
S6: ARM-ELEVATION DOWN — UP
S7: START/STOP START — STOP
S101: POWER ON — OFF
The underlined indicates the switch position.

2SA816
2SC1626

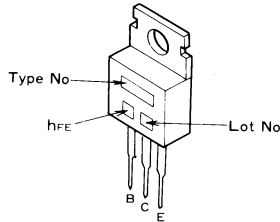

TC4001BP
TC4011BP
TC4013BP
TC4023BP
TC4069UBP

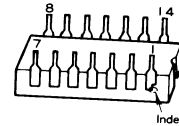

This is the basic schematic diagram, but the actual circuit may vary due to improvements in design.

2SA671
2SC106

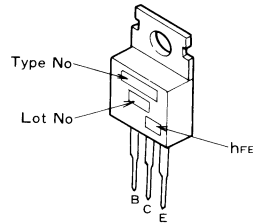

NJM2903
 μ PC4558

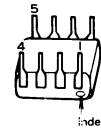

B

PA2005

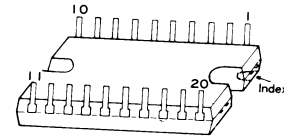

2SC1583

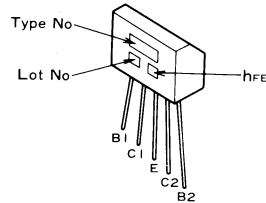

μ PC78M08H

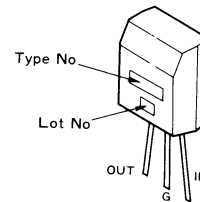

C

2SD686

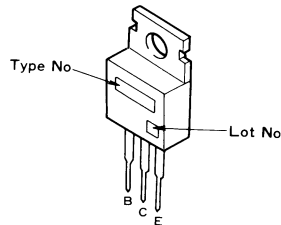

μ PC78L08

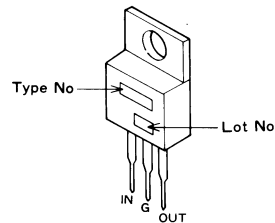

D

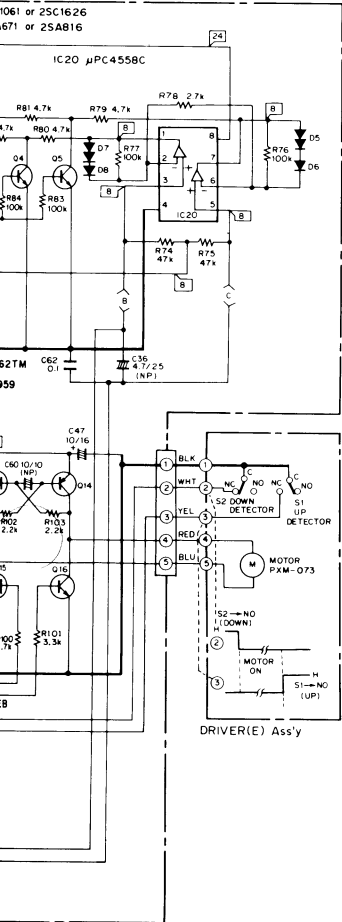
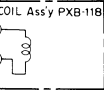

7

8

9

13. P.C.BOARD CONNECTION DIAGRAM (HET,HBT MODEL)

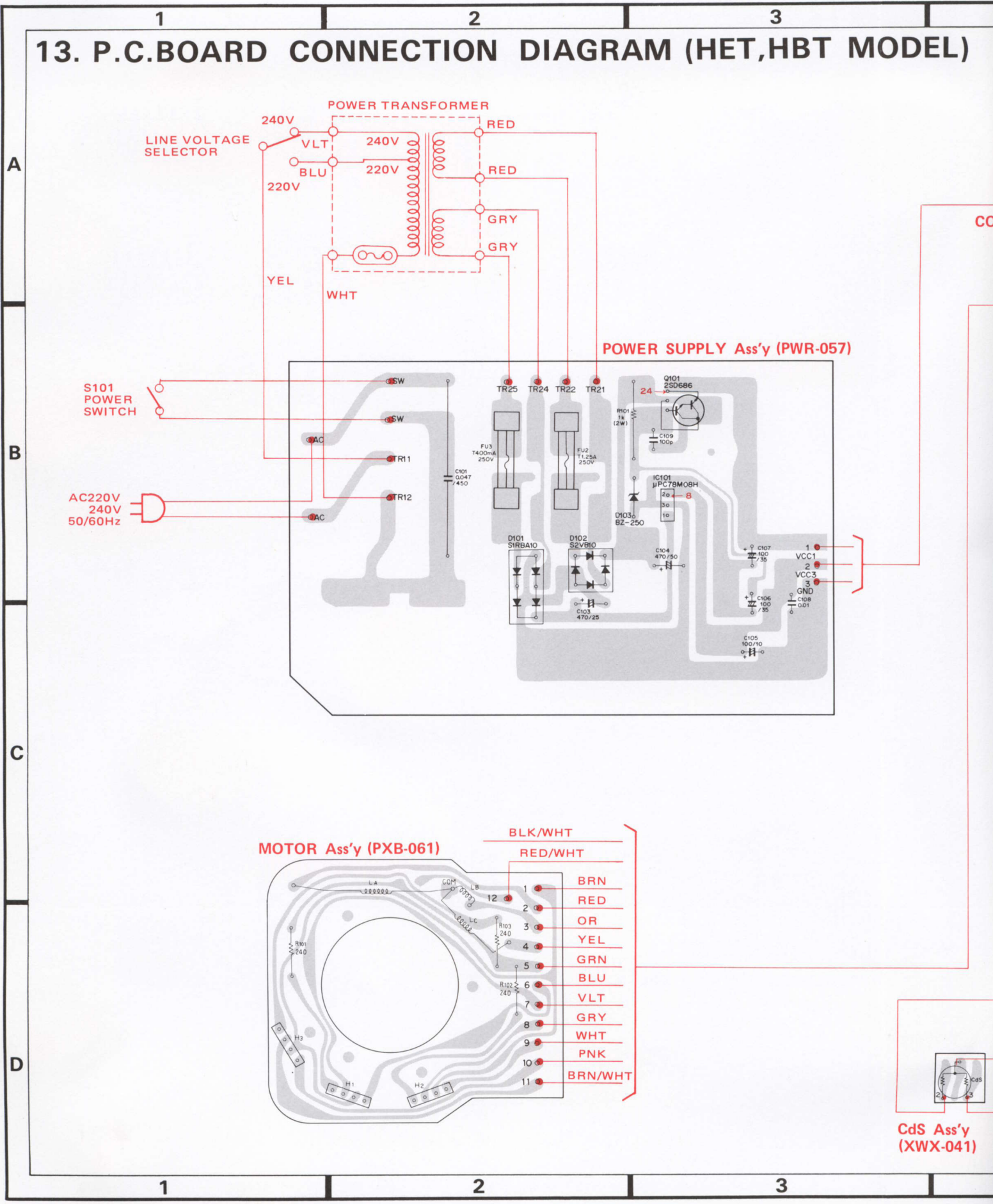

MODEL)

COIL Ass'y (PXB-118)

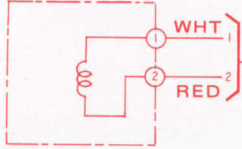

CONTROL Ass'y (PWM-032)

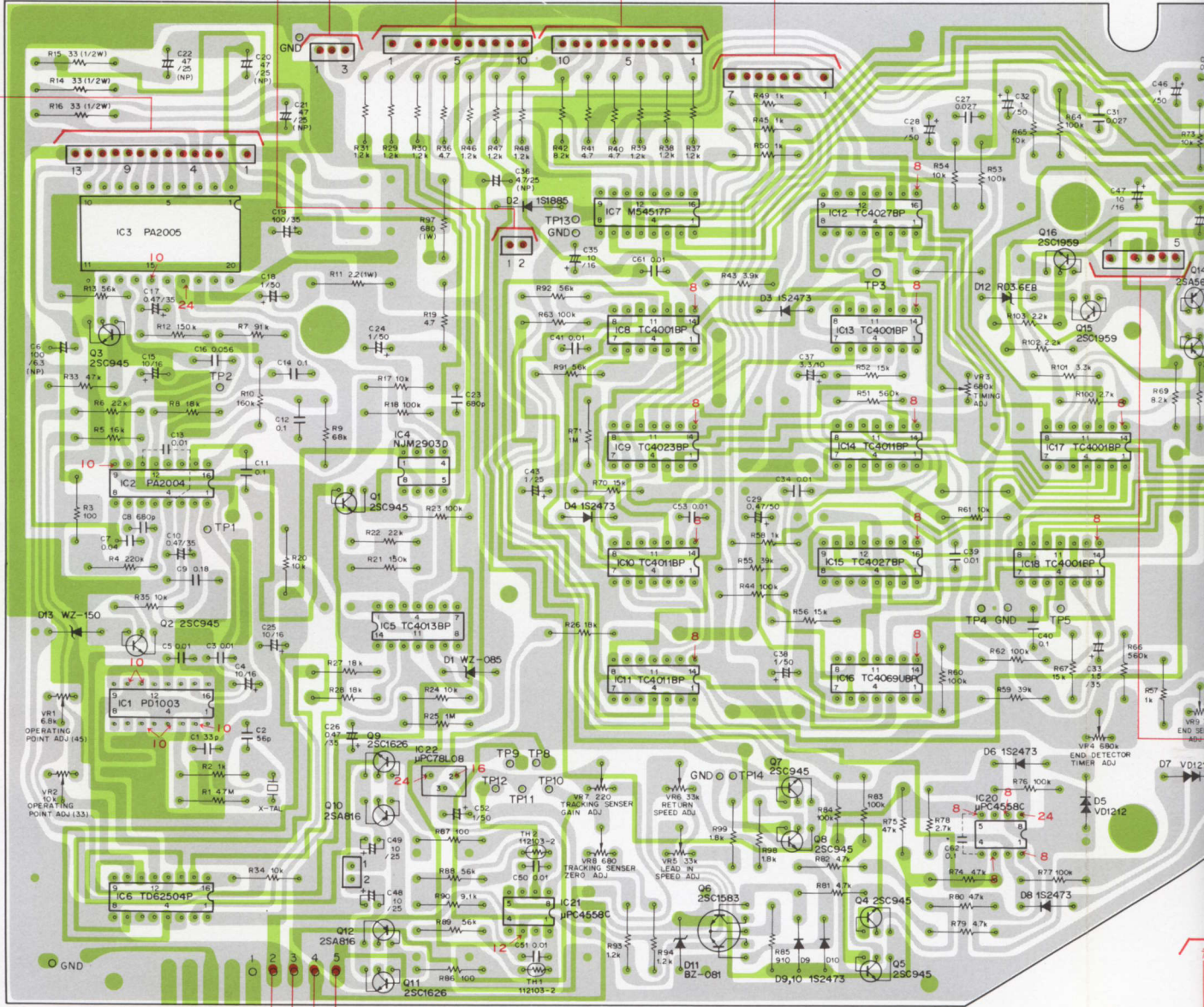

CdS Ass'y (XWX-041)

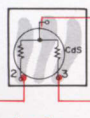

LAMP Ass'y (XWX-040)

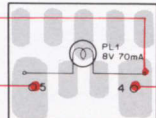
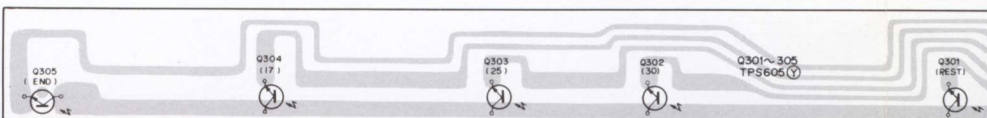

PHOTO Tr. Ass'y (XWX-043)



14. PARTS LIST OF P.C.BOARD ASSEMBLY (HET,HBT MODEL)

NOTE:

- When ordering resistors, first convert resistance values into code form as shown in the following examples.

Ex. 1 When there are 2 effective digits (any digit apart from 0), such as 560 ohm and 47k ohm (tolerance is shown by J = 5%, and K = 10%).

560Ω	—	56 × 10 ¹	—	561	RD¼PS	561J
47kΩ	—	47 × 10 ³	—	473	RD¼PS	473J
0.5Ω	—	0R5			RN2H	0R5K
1Ω	—	010			RS1P	010K

Ex. 2 When there are 3 effective digits (such as in high precision metal film resistors).

5.62kΩ		562 × 10 ¹		5621	RN¼SR	5621F
--------	--	-----------------------	--	------	-------	-------	-------

- The Δ mark found on some component parts indicates the importance of the safety factor of the part. Therefore, when replacing, be sure to use parts of identical designation.

Parts List of Control Assembly (PWM-032)

SEMICONDUCTORS

Part No.	Symbol & Description
PD1003	IC1
PA2004	IC2
PA2005	IC3
NJM2903D	IC4
JC4013BP	IC5
TD62504P	IC6
M54517P	IC7
TC4001BP	IC8, IC13, IC17, IC18
TC4023BP	IC9
TC4011BP	IC10, IC11, IC14
TC4027BP	IC12, IC15
TC4069UBP	IC16
μPC4558C	IC20, IC21
μPC78L08	IC22
2SC945 (2SC1815)	Q1—Q5, Q7, Q8
2SC1583	Q6
2SC1626	Q9, Q11
2SA816	Q10, Q12
2SA562TM-Y	Q13, Q14
2SC1959-Y	Q15, Q16
WZ-085	D1
IS1885	D2
IS2473	D3, D4, D6, D8—D10, D14, D15
VD1212	D5, D7
RD2.4EB	D12
WZ-150	D13

Note: When ordering resistors, convert the resistance value into code form, and then rewrite the part no. as before.

RESISTORS

Part No.	Symbol & Description
RD¼PS □□□ J	R1—R10, R12—R31, R33—R53, R55—R92, R98—R104, R110
RN1P2R2J	R11
RN¼PS 1301 G	R93, R94
RS1PF 681J	R97
PCP-031	VR1 6.8K-B
PCP-012	VR2 10K-B
PCP-049	VR3 680K-B
PCP-037	VR4 680K-B
PCP-048	VR5, VR6 33K-B
PCP-047	VR7 220-B
PCP-038	VR8 330-B
PCP-001	VR9 3.3K-B

CAPACITORS

Part No.	Symbol & Description
CCDCH 330J 50	C1
CCDCH 560J 50	C2
CKDYF 103Z 50	C3, C5, C13, C50, C51, C53, C61
CEA 100P 16	C4, C25, C35, C47
CEA 101M 6.3NP	C6
CKDYF 403Z 50	C7
CKDYB 681K 50	C8, C23
CQMA 184J 50	C9
CSZA R47M 35	C10, C17, C26
CQMA 104K 50	C11, C12, C14, C40

Part No.	Symbol & Description
CSZA 100M 16	C15
CQMA 563K 50	C16
CEA 010P 50	C18, C24, C28, C32, C38, C46, C52
CEA 101M 35L	C19
CEA 470M 25NP	C20-C22
CQMA 273K 50	C27, C31, C45
CEA R47P 50	C29
CSZA 1R5K 50	C33
CQMA 103K 50	C34, C39, C41
CEA 4R7M 25NP	C36
CSZA 3R3K 10	C37
CSZA 010K 25	C43
CEA 100P 25	C48, C49
CEA 100M 10NP	C60
CKDYF 104Z 50	C62

OTHERS

Part No.	Symbol & Description
PSS-003	X'tal
112103-2	TH1, TH2

Parts List of Power Supply Assembly (PWR-057)

Part No.	Symbol & Description
μPC78MD8H	IC101
2SD686	Q101
PCX-010	D101
S2VB10	D102
BZ-250	D103
RS2PF102J	R101
⚠ PCL-024	C101 0.047/450
CEA 471M 25L	C103
CEA 471M 50L	C104
CEA 101P 10	C105
CEA 101M 35L	C106, C107
CKDYF 103Z 50	C108
CCDSL 101K 50	C109
PNM-013	Spacer
PNX-015	Spacer
PBA-089	Screw
⚠ PEA-005	Fuse 400mA
⚠ PEK-036	Fuse 1.25A

Parts List of Lamp Assembly (XWX-040)

Part No.	Symbol & Description
PEL-041	PL1 8V 70mA

Parts List of LED Assembly (XWX-042)

Part No.	Symbol & Description
TLR-121	D301-D305
RD½PS 103J	R301

Parts List of Cds Assembly (XWX-041)

Part No.	Symbol & Description
PCX-051	Cds

Parts List of Photo Tr Assembly (XWX-043)

Part No.	Symbol & Description
TPS605	Q301-Q305

Parts List of Control A Assembly (XWX-044)

Part No.	Symbol & Description
GL-2PR1	D201-D206
PSG-022	S3, S4

Parts List of Control B Assembly (XWX-045)

Part No.	Symbol & Description
GL-2PR1	D207-D209
PSG-022	S5-S7

15. SCHEMATIC DIAGRAM(S/G MODEL)

A

B

C

D

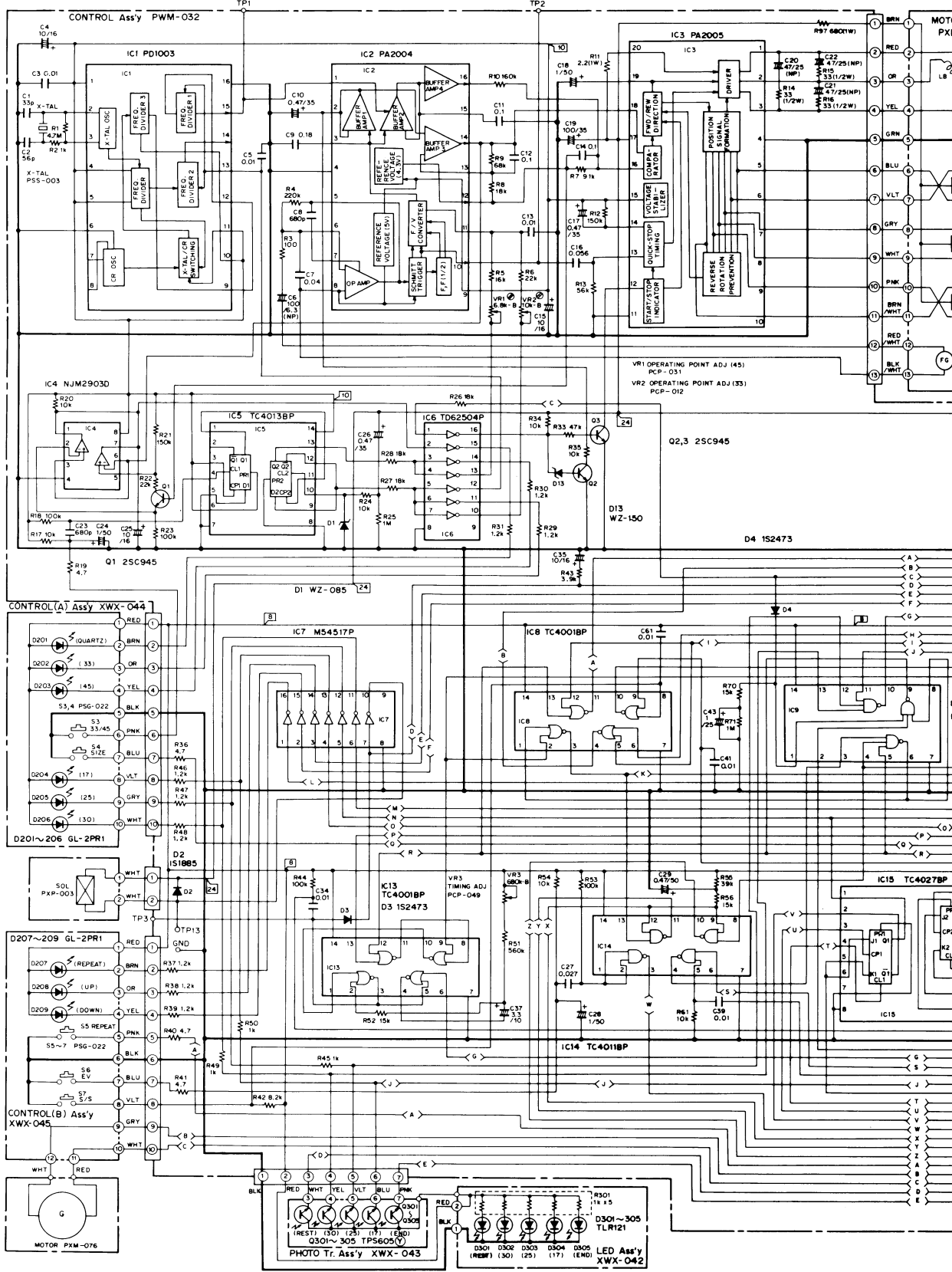

1

2

3

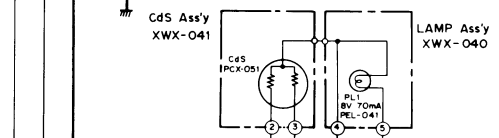
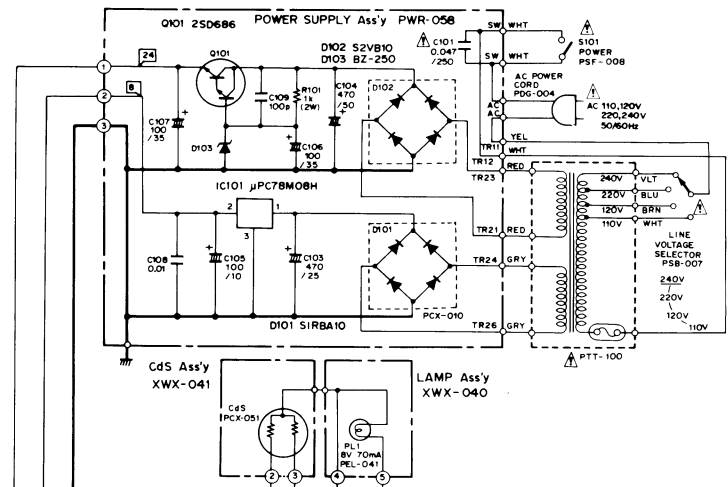
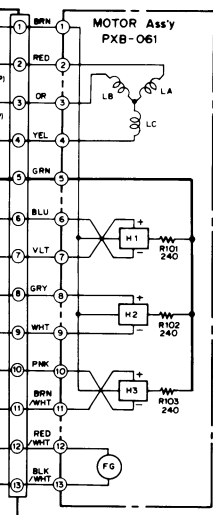

1. RESISTORS:
Indicated in Ω, ¼W, ±5% tolerance unless otherwise noted k, kΩ, M: MΩ, (F): ±1%, (G): ±2%, (K): ±10% tolerance
2. CAPACITORS:
Indicated in capacity (μF)/voltage (V) unless otherwise noted p: pF
Indication without voltage is 50V except electrolytic capacitor.
3. VOLTAGE
□ DC Voltage (V) at no input signal
○ Adjusting point.
4. OTHERS:
The Δ mark found on some component parts indicates the importance of the safety factor of the part. Therefore, when replacing, be sure to use parts of identical designation.

- SWITCHES:
S1: UP DETECTOR ON — OFF
S2: DOWN DETECTOR ON — OFF
S3: SPEED 33 rpm — 45
S4: SIZE 17 — 25 — 3
S5: REPEAT ON — OFF
S6: ARM-ELEVATION DOWN — UP
S7: START/STOP START — STOP
S101: POWER ON — OFF
- The underlined indicates the switch position.

This is the basic schematic diagram, but the due to improvements in design.

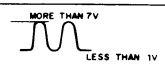
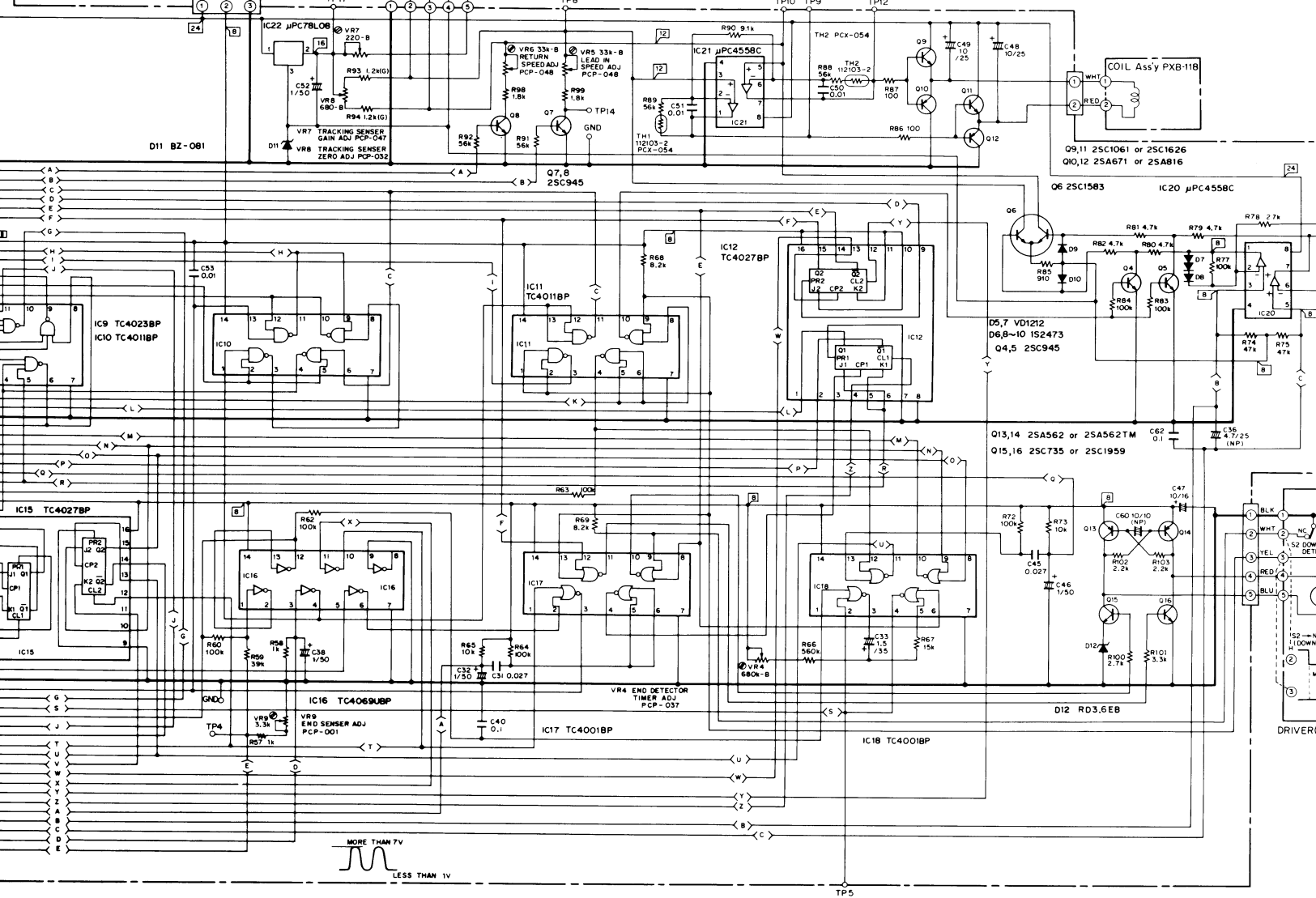

7

8

9

A

B

C

D

- SWITCHES:
- | | |
|-------------------|-----------------|
| S1: UP DETECTOR | ON — OFF |
| S2: DOWN DETECTOR | ON — OFF |
| S3: SPEED | 33 rpm — 45 rpm |
| S4: SIZE | 17 — 25 — 30 |
| S5: REPEAT | ON — OFF |
| S6: ARM-ELEVATION | DOWN — UP |
| S7: START/STOP | START — STOP |
| S101: POWER | ON — OFF |
- The underlined indicates the switch position.

This is the basic schematic diagram, but the actual circuit may vary due to improvements in design.

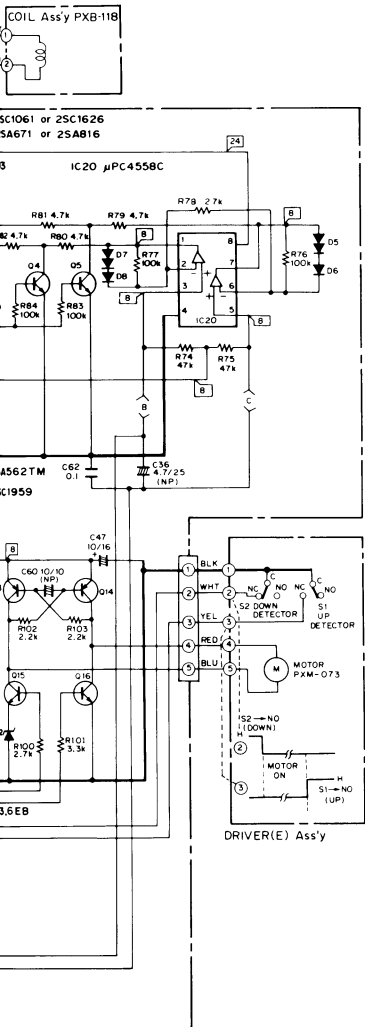

7

8

9

16. P.C.BOARD CONNECTION DIAGRAM(S/G MODEL)

A
B
C
D

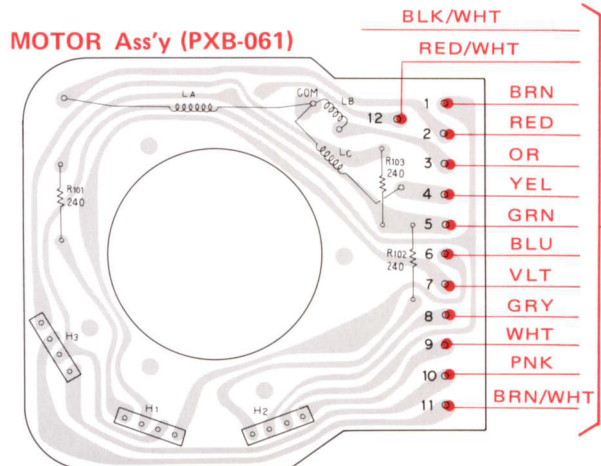
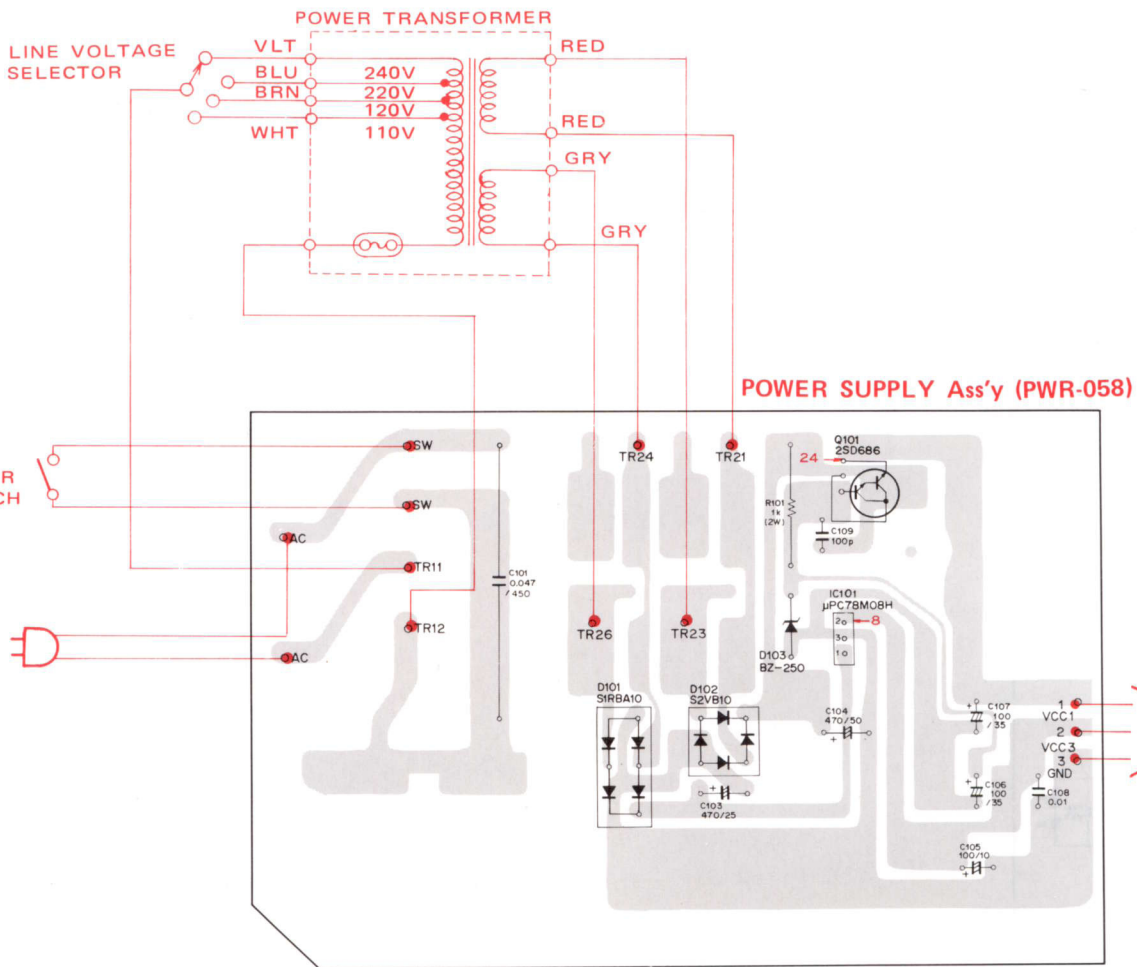

17. PARTS LIST OF P.C.BOARD ASSEMBLY (S/G MODEL)

NOTE:

- When ordering resistors, first convert resistance values into code form as shown in the following examples.

Ex. 1 When there are 2 effective digits (any digit apart from 0), such as 560 ohm and 47k ohm (tolerance is shown by J = 5%, and K = 10%).

560Ω	— 56 × 10 ¹ —	561	RD¼PS	561 J
47kΩ	— 47 × 10 ³ —	473	RD¼PS	473 J
0.5Ω	— 0R5		RN2H	05 K
1Ω	— 010		RS1P	010 K

Ex. 2 When there are 3 effective digits (such as in high precision metal film resistors).

5.62kΩ	562 × 10 ¹	5621	RN¼SR	5621 F
--------	-----------------------	------	-------	-------	--------

- The Δ mark found on some component parts indicates the importance of the safety factor of the part. Therefore, when replacing, be sure to use parts of identical designation.

Parts List of Control Assembly (PWM-032)

Note: When ordering resistors, convert the resistance value into code form, and then rewrite the part no. as before.

SEMICONDUCTORS

Part No.	Symbol & Description
PD1003	IC1
PA2004	IC2
PA2005	IC3
NJM2903D	IC4
JC4013BP	IC5
TD62504P	IC6
M54517P	IC7
TC4001BP	IC8, IC13, IC17, IC18
TC4023BP	IC9
TC4011BP	IC10, IC11, IC14
TC4027BP	IC12, IC15
TC4069UBP	IC16
μPC4558C	IC20, IC21
μPC78L08	IC22
2SC945	Q1—Q5, Q7, Q8
(2SC1815)	
2SC1583	Q6
2SC1626	Q9, Q11
2SA816	Q10, Q12
2SA562TM-Y	Q13, Q14
2SC1959-Y	Q15, Q16
WZ-085	D1
IS1885	D2
IS2473	D3, D4, D6, D8—D10, D14, D15
VD1212	D5, D7
RD2.4EB	D12
WZ-150	D13

RESISTORS

Part No.	Symbol & Description
RD¼PS □□□ J	R1—R10, R12—R31, R33—R53, R55—R92, R98—R104, R110
RN1P2R2J	R11
RN¼PS 1301 G	R93, R94
RS1PF 681J	R97
PCP-031	VR1 6.8K-B
PCP-012	VR2 10K-B
PCP-049	VR3 680K-B
PCP-037	VR4 680K-B
PCP-048	VR5, VR6 33K-B
PCP-047	VR7 220-B
PCP-038	VR8 330-B
PCP-001	VR9 3.3K-B

CAPACITORS

Part No.	Symbol & Description
CCDCH 330J 50	C1
CCDCH 560J 50	C2
CKDYF 103Z 50	C3, C5, C13, C50, C51, C53, C61
CEA 100P 16	C4, C25, C35, C47
CEA 101M 6.3NP	C6
CKDYF 403Z 50	C7
CKDYB 681K 50	C8, C23
CQMA 184J 50	C9
CSZA R47M 35	C10, C17, C26
CQMA 104K 50	C11, C12, C14, C40

Part No.	Symbol & Description
CSZA 100M 16	C15
CQMA 563K 50	C16
CEA 010P 50	C18, C24, C28, C32, C38, C46, C52
CEA 101M 35L	C19
CEA 470M 25NP	C20--C22
CQMA 273K 50	C27, C31, C45
CEA R47P 50	C29
CSZA 1R5K 50	C33
CQMA 103K 50	C34, C39, C41
CEA 4R7M 25NP	C36
CSZA 3R3K 10	C37
CSZA 010K 25	C43
CEA 100P 25	C48, C49
CEA 100M 10NP	C60
CKDYF 104Z 50	C62

OTHERS

Part No.	Symbol & Description
PSS-003	X'tal
112103-2	TH1, TH2

Parts List of Power Supply Assembly (PWR-058)

Part No.	Symbol & Description
μ PC78MD8H	IC101
2SD686	Q101
PCX-010	D101
S2VB10	D102
BZ-250	D103
RS2PF102J	R101
⚠ PCL-005	C101 0.047/450
CEA 471M 25L	C103
CEA 471M 50L	C104
CEA 101P 10	C105
CEA101M 35L	C106, C107
CKDYF 103Z 50	C108
CCDSL 101K 50	C109
PNM-013	Spacer
PNX-015	Spacer
PBA-089	Screw

Parts List of Lamp Assembly (XWX-040)

Part No.	Symbol & Description
PEL-041	PL1 8V 70mA

Parts List of LED Assembly (XWX-042)

Part No.	Symbol & Description
TLR-121	D301--D305
RD $\frac{1}{2}$ PS 103J	R301

Parts List of Cds Assembly (XWX-041)

Part No.	Symbol & Description
PCX-051	Cds

Parts List of Photo Tr Assembly (XWX-043)

Part No.	Symbol & Description
TPS605	Q301--Q305

Parts List of Control A Assembly (XWX-044)

Part No.	Symbol & Description
GL-2PR1	D201--D206
PSG-022	S3, S4

Parts List of Control B Assembly (XWX-045)

Part No.	Symbol & Description
GL-2PR1	D207--D209
PSG-022	S5--S7

PIONEER ELECTRONIC CORPORATION 4-1, Meguro 1-Chome, Meguro-ku, Tokyo 153, Japan
U.S. PIONEER ELECTRONICS CORPORATION 85 Oxford Drive, Moonachie, New Jersey 07074, U.S.A.
PIONEER ELECTRONIC (EUROPE) N.V. Luithagen-Haven 9, 2030 Antwerp, Belgium
PIONEER ELECTRONICS AUSTRALIA PTY. LTD. 178-184 Boundary Road, Braeside, Victoria 3195, Australia