

**571 SPL Computer**



**571**

**User's Guide**

## Table of Contents

---

<i>Chapter 1</i>	Introduction	1
<i>Chapter 2</i>	Operator Safety Summary	3
<i>Chapter 3</i>	Setup	4
	Calibration Checklist	6
<i>Chapter 4</i>	Front & Rear Panel Overview	7
<i>Chapter 5</i>	571 Basics	9
<i>Chapter 6</i>	Technical Tutorial	11
<i>Chapter 7</i>	Using the 571	14
<i>Chapter 8</i>	Applications	16
<i>Chapter 9</i>	Troubleshooting	18
<i>Chapter 10</i>	Specifications	19
<i>Chapter 11</i>	Warranty & Service	20
<i>Appendix A</i>	Calibration: Special Cases	22
<i>Appendix B</i>	Stereo Slave Operation	23
<i>Appendix C</i>	Connections	24
<i>Appendix D</i>	Declaration of Conformity	25

Rev C.00, 24 March, 1999

Symetrix part number 53571-0C00

Subject to change without notice.

©1999, Symetrix, Inc. All right reserved.

Symetrix is a registered trademark of Symetrix, Inc.

Mention of third-party products is for informational purposes only and constitutes neither an endorsement nor a recommendation. Symetrix assumes no responsibility with regard to the performance or use of these products.

Under copyright laws, no part of this manual may be reproduced or transmitted in any form or by any means, electronic or mechanical, including photocopying, scanning, recording or by any information storage and retrieval system, without permission, in writing, from Symetrix, Inc.

 **Symetrix**  
6408 216th St. SW  
Mountlake Terrace, WA 98043 USA  
Tel (425) 778-7728  
Fax (425) 778-7727  
Email [symetrix@symetrixaudio.com](mailto:symetrix@symetrixaudio.com)

# 571

The Symetrix 571 is an ambient noise sensing automatic level controller or SPL computer.

The 571 uses one or two sensing microphones, located in the coverage zone of the sound system, to continuously sample the loudness of ambient sounds.

The 571’s microprocessor, running proprietary embedded software, computes how loud the sound system should be, based on the current ambient conditions measured by the sensing microphone(s). The gain computation uses a combination of the current ambient environment and “experience” gained during the unit’s on-site calibration procedure. The 571 adds or subtracts enough gain to operate the sound system at the computed level.

Semiautomatic calibration makes the 571 very easy to set up. The calibration procedure requires no test equipment and typically takes less than one minute. Internal nonvolatile memory stores the calibration parameters until they are changed, and the memory will survive indefinitely in the absence of AC power. Once calibrated, the 571 predicts how the environment should respond under all possible operating conditions. The SPL computer’s proprietary software allows the 571 to differentiate between environmental noise and music/paging signals.

Calibrate the SPL computer and its associated sound system when the room is at its quietest. Pressing the mode switch tells the microprocessor to begin the calibration routine. When the SET MIN indicator flashes, use the LEVEL SET MIN control to set the sound system’s minimum output level. When the SET MAX indicator flashes, use the LEVEL SET MAX control to set the sound system’s maximum operating level. The SPL computer puts those settings into memory along with their respective SPL’s, then returns the unit to normal operating mode.

The 571 also includes a mic-level paging input, a balanced line-level paging input, a balanced input for background or foreground music, and page-over music capability (music ducking).

A multi-segment LED bargraph indicates the internal gain of the 571 during operation and serves as a prompting device during calibration.

The inputs of the 571 are a combination of XLR connectors and screw terminals. The output connections are also screw terminals. All audio inputs and outputs are balanced. Mic-level inputs (sensing and paging) accept 150 Ohm balanced sources. Line-level inputs are 10k Ohm balanced bridging, +4 dBu signal level.

Feel free to contact us if you have questions, comments, or suggestions:

- Phone: (425)778-7728
- Fax: (425)778-7727
- Email: [symetrix@symetrixaudio.com](mailto:symetrix@symetrixaudio.com)
- Website: [www.symetrixaudio.com](http://www.symetrixaudio.com)

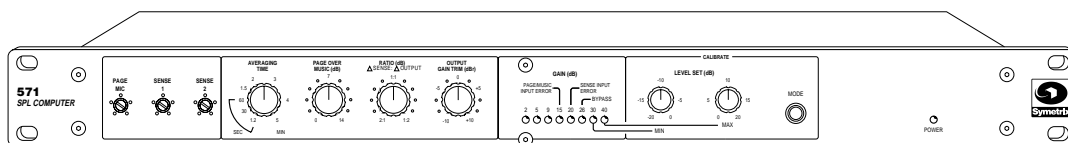

Front panel

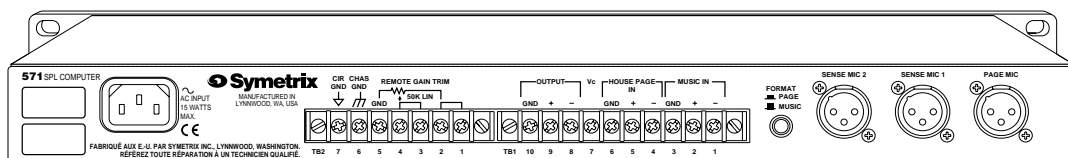

Rear panel



## Do You Have The Right Unit?

Symetrix makes two different SPL computers: the 571 and the 572. Although both units perform essentially the same task, they are different.

The 571 requires an external sensing microphone(s) to monitor ambient conditions. The 571 works in real time; adjustments are made continuously, regardless of music, paging, or silence. The 571 **does not** interrupt the signal path at any time.

The 572 uses the sound system loudspeaker(s) to monitor ambient conditions. Doing this requires the 572 to monitor the incoming program material for silent sections. Once the 572 detects silence, it switches to sense mode, switching the loudspeaker(s) from the amplifier output to its sense input. Sensing takes one to two seconds. Any signal applied to the paging inputs during this time immediately terminates the sense period. If a silent period never occurs, the 572 forces one. A front-panel control determines the length of time that elapses before a forced sense occurs. Sensing may also be triggered externally. The 572 **interrupts** the signal path during sensing. Table 1-1 provides a tabular comparison of the two units.

<u>Feature</u>	<u>571</u>	<u>572</u>
Uses dedicated microphone for ambient sensing .....	Y	N
Uses sound system speakers for ambient sensing .....	N	Y
Sound system loudness controlled by ambient noise conditions .....	Y	Y
Continuous, real time operation .....	Y	N
Program silence sensing triggers ambient sense period .....	N	Y
Mic and line level paging inputs .....	Y	Y
Page over music (ducking) .....	Y	Y
Music + page mixing .....	Y	Y
Calibration required .....	Y	Y
Timed ambient sensing .....	N	Y
Interrupts signal path during sensing .....	N	Y

Table 1-1. 571 - 572 Feature comparison.

# 571

## Equipment Markings

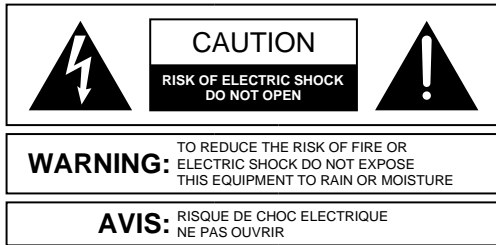

SEE OWNERS MANUAL. VOIR CAHIER D'INSTRUCTIONS.  
 No user serviceable parts inside. Refer servicing to qualified service personnel.  
 Il ne se trouve a l'interieur aucune piece pouvant etre reparaee l'usager.  
 S'adresser a un reparaateur competent.

The lightning flash with arrowhead symbol within an equilateral triangle is intended to alert the user of the presence of uninsulated “dangerous voltage” within the product’s enclosure that may be of sufficient magnitude to constitute a risk of electric shock to persons. The exclamation point within an equilateral triangle is intended to alert the user of the presence of important operating and maintenance (servicing) instructions in the literature accompanying the product (i.e. this manual).

**Caution** *To prevent electric shock, do not use the polarized plug supplied with the unit with any extension cord, receptacle, or other outlet unless the blades can be fully inserted.*

## Terms

Several notational conventions are used in this manual. Some paragraphs may use **Note**, **Caution**, or **Warning** as a heading. Certain typefaces and capitalization are used to identify certain words. These are:

<b>Note</b>	Identifies information that needs extra emphasis. A <b>Note</b> generally supplies extra information to help you to better use the 571.
<b>Caution</b>	<i>Identifies information that, if not heeded, may cause damage to the 571 or other equipment in your system.</i>
<b>Warning</b>	<b>Identifies information that, if ignored, may be hazardous to your health or that of others.</b>
<b>CAPITALS</b>	Controls, switches or other markings on the 571’s chassis.
<b>Boldface</b>	Strong emphasis.

## Important Safety Instructions

Please read and keep these instructions. Heed and follow all warnings and instructions. Install in accordance with the manufacturer’s instructions.

**Power Source** This product is intended to operate from a power source that does not apply more than 250V rms between the power supply conductors or between either power supply conductor and ground. A protective ground

connection, by way of the grounding conductor in the power cord, is essential for safe operation.

**Grounding** The chassis of this product is grounded through the grounding conductor of the power cord. To avoid electric shock, plug the power cord into a properly wired receptacle before making any connections to the product. A protective ground connection, by way of the grounding conductor in the power cord, is essential for safe operation. **Do not defeat the safety purpose of the grounding plug.** The grounding plug has two blades and a third grounding prong. The third prong is provided for your safety. When the provided plug does not fit your outlet, consult an electrician for replacement of the obsolete outlet.

**Danger from Loss of Ground** If the protective ground connection is lost, all accessible conductive parts, including knobs and controls that may appear to be insulated, can render an electric shock.

**Proper Power Cord** Use only the power cord and connector specified for the product and your operating locale. Use only a cord that is in good condition. **Protect the power cord** from being walked on or pinched, particularly at plugs, convenience receptacles, and the point where they exit from the apparatus.

**Proper Fuse** The user accessible fuse is a part of the IEC AC inlet connector. The fuseholder accepts 5 x 20mm diameter fuses. For 117VAC operation, the correct value is 0.25A, 250VAC, standard. For 230VAC operation, the correct value is 0.125A, 250VAC, standard.

**Operating Location Do not operate this equipment under any of the following conditions:** explosive atmospheres, in wet locations, in inclement weather, improper or unknown AC mains voltage, or if improperly fused. Do not install near any heat source such as radiators, heat registers, stoves, or other apparatus (including amplifiers) that produce heat. Unplug this apparatus during lightning storms or when unused for long periods of time.

**Stay Out of the Box** To avoid personal injury (or worse), do not remove the product covers or panels. Do not operate the product without the covers and panels properly installed. Only use accessories specified by the manufacturer. Clean only with a damp cloth.

**User-serviceable parts** There are no user serviceable parts inside the 571. In case of failure, refer all servicing to the factory. Servicing is required when the 571 has been damaged in any way, such as when a power supply cord or plug is damaged, liquid has been spilled or objects have fallen into the apparatus, the apparatus has been exposed to rain or moisture, does not operate normally, or has been dropped.

571

**Place the 571 in the signal chain as the final level controlling device.** It is imperative that any gain or level controls used in the signal chain after the 571 remain unchanged once the unit has been calibrated. This includes wall mounted autoformer and L-pad speaker-level controls used for zone balancing.

Equalizers following the 571 are acceptable **IF** their controls (both EQ and level) will not be changed after calibration.

Level controls in the signal chain before the SPL Computer are acceptable, because the unit “reads” input level changes. Note that the 571 is equipped with a remote-controllable output gain trim control that provides overall level control. This is discussed in greater detail in Chapter 5.

**The rear panel format (page/music) switch must reflect how the unit will be used.** The 571 must be calibrated in the same conditions in which it will be used. Erratic operation results from calibrating the unit with this switch in the wrong position.

**Music and Paging** - When the system will be used for both foreground/background music and paging, set the FORMAT switch to MUSIC mode.

**Paging only** - When the system will be used for paging *only*, set the FORMAT switch to PAGE mode. In this mode, the music input is disabled.

**Calibrate the 571 when ambient noise is at its lowest level.** “Lowest level” means the ambient noise level that is the minimum for that particular environment, no matter what the actual level may be.

The ambient noise level measured by the 571 during the calibration procedure is used by the microprocessor as a baseline for calculating gain changes. Thus, the ambient level in the controlled space should be at a normal minimum level. If the ambient noise level is too high during calibration, the overall control range may be inadequate. For additional information, refer to Appendix B.

**During calibration, run normal program signals through the system.** This allows the SPL Computer to develop an acoustical performance history of the environment based upon the type of material that will ordinarily be run through the system. No extra test equipment is required for normal calibration. However, to set the system up for specific operating levels, a noise source and SPL meter are needed. For additional information, refer to Appendix B.

## Connections

A drawing of a typical music with paging system is shown in Figure 3-1 on the next page. Make all of the following connections:

1. One or more sensing microphones to the SENSE MIC 1 and SENSE MIC 2 XLR connectors. For most installations, only one mic is needed.
2. Paging microphone (or mic-level mixer output) to the PAGE MIC XLR connector.
3. Line-level paging source (or other source) to the HOUSE PAGE IN terminals on TB1.
4. Line-level music source to the MUSIC IN terminals on TB1.
5. SPL Computer output from TB1 to your sound system’s amplifier(s).
6. Ensure that TB2-3 and TB2-4 are bridged (connected), or that a remote gain pot is connected.
7. Ensure that TB2-1 and TB2-2 are bridged (connected), or that a remote gain pot is connected.

**Caution** *Failure to connect the 571 to the proper AC mains voltage may cause fire and/or internal damage. There are no user serviceable parts inside the chassis. Refer all service to qualified service personnel or to the factory.*

**Warning** **Lethal voltages are present inside the chassis. There are no user serviceable parts inside the chassis. Refer all service to qualified service personnel or to the factory.**

Connect the AC input to an AC power source of the proper voltage and frequency, as marked on the rear of the unit.

# 571

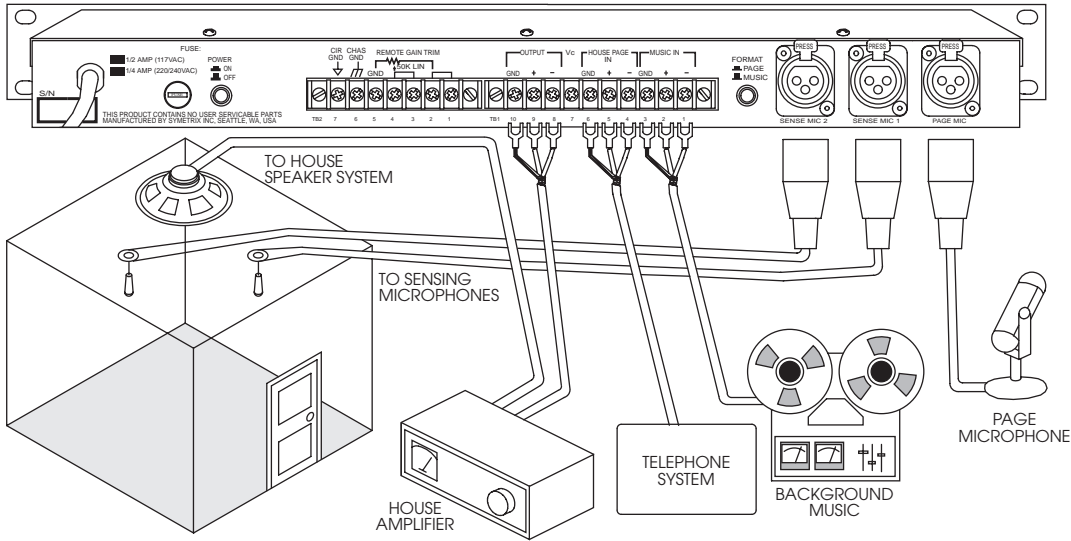

Figure 3-1. 571 generic hookup diagram.

## Settings

Set the controls and switches on the front and rear panel as shown in Table 3-2.

Front Panel Control	Setting	Rear Panel	Connection or Setting
PAGE Mic trimpot	12:00 o'clock	OUTPUT	Connect to power amplifiers.
SENSE 1 AND SENSE 2 trimpots	12:00 o'clock	SENSE INPUTS	Connect balanced, low-impedance sensing microphones.
AVERAGING TIME	8:00 o'clock	PAGE MIC	Connect balanced, low-impedance page microphone.
PAGE OVER MUSIC	8:00 o'clock	MUSIC IN	Connect line-level music source.
RATIO	12:00 o'clock	HOUSE PAGE IN	Connect line-level paging source.
OUTPUT GAIN TRIM	12:00 o'clock	FORMAT Switch	OUT
LEVEL SET MIN	9:00 o'clock		
LEVEL SET MAX	8:00 o'clock		

Table 3-2. Front and rear panel control and switch settings.

# 571

---

## Calibration Checklist

---

Initiate the calibration procedure by pressing the MODE switch once (from OPERATE mode). The rear-panel FORMAT switch sets the overall control format.

**Note** The format switch must be in the proper position for calibration.

Complete the following checklist before beginning the calibration procedure.

1. Complete all input and output connections.
2. Verify that the unit passes signal in the BYPASS mode. Enter BYPASS mode by pressing the MODE switch twice, from OPERATE mode. Press the MODE switch once more to return to OPERATE mode.
3. Set the FORMAT switch to the proper position.
  - In PAGE mode, the calibration procedure cannot be completed without normal level paging signals at either the PAGE MIC input or the HOUSE PAGE input.
  - In MUSIC mode, the calibration procedure cannot be completed without normal level signals at the MUSIC IN or PAGE IN line inputs, or at the PAGE MIC input.
4. Connect at least one sensing mic. Be sure to turn it on if it has a switch.
5. Set the front panel controls as shown in Table 3-2.
6. Set the rear panel controls as shown in Table 3-2.

**Caution** *The OUTPUT GAIN TRIM control is ignored during calibration. When calibration is completed and the unit returns itself to OPERATE mode, the output level reflects the setting of this control.*

*When the unit is put into BYPASS mode, the unit ignores the setting of the OUTPUT GAIN TRIM control. If, for example, it is set for reduced gain, the overall gain returns to unity when the unit goes into BYPASS mode.*

*The 571 delivers unity gain when the output is operated unbalanced, and the gain is +6 dB when the balanced output is used.*

## Calibration Procedure

---

1. Press the MODE switch once to enter CALIBRATION mode.
2. Using the 571's LEVEL SET MIN control, adjust the control for the minimum desired operating level when the LED bargraph indicator marked SET MIN flashes.
3. Using the 571's LEVEL SET MAX control, adjust the control for the maximum desired operating level when the LED bargraph indicator marked SET MAX flashes.

The 571 “listens” to the sound system for about 8 seconds at the minimum level (after it detects the last adjustment of the MIN control), and then for about 8 seconds at the maximum level (after the last adjustment of the MAX control). Then the microprocessor returns the unit to OPERATE mode under the new calibration values.

When the calibration procedure is completed, the acoustic performance record of the room is placed in nonvolatile memory along with the minimum and maximum level settings. The unit will operate under these calibration settings until the calibration procedure is run again.

The calibration procedure may be run as many times as necessary. If for any reason the procedure is interrupted before completion, the unit returns to operate mode under the previously stored values. If the procedure is run to completion with no changes, the unit calculates the same values as it did under the previous calibration procedure, and puts those new values into nonvolatile memory. Only when the LEVEL SET MAX or LEVEL SET MIN setting is changed, and the 571 is recalibrated, does the unit put new operating values into memory.



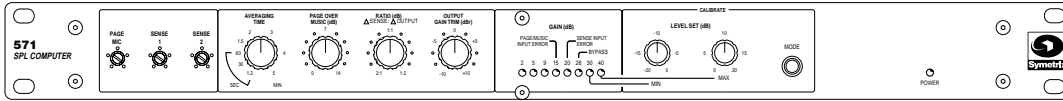

**PAGE MIC Trimpot** - Screwdriver adjust level control provides up to 26dB attenuation of signals from the page mic preamp. This control does not affect the House Page input. This control is always active, regardless of the 571's operating mode.

**SENSE MIC 1 Trimpot** - Screwdriver adjust level control provides up to 40dB attenuation of signals from the sense mic 1 preamp. This control is always active, regardless of the 571's operating mode. Do not adjust this control after calibration.

**SENSE MIC 2 trimpot** - Screwdriver adjust level control provides up to 40dB attenuation of signals from the sense mic 2 preamp. This control is always active, regardless of the 571's operating mode. Do not adjust this control after calibration.

**AVERAGING TIME Control** - Sets the time period, in seconds or minutes, used by the 571 for averaging sound pressure level changes: from 1.2 seconds to 5 minutes. Also affects the time required to change the SPL to its newly computed value.

**PAGE OVER MUSIC control** - Determines attenuation applied to music signals during paging announcements: from 0dB to -14dB.

**RATIO Δ SENSE: Δ OUTPUT Control** - Sets the ambient/gain ratio: from 2:1 to 1:2. This determines whether the 571 makes a smaller gain change than the ambient level(2:1) or a larger gain change than the ambient level(1:2).

**OUTPUT GAIN TRIM control** - Provides manual adjustment of overall output gain over a 20 dB range, at any time. This control may be remotely located, which disables the front panel output gain control.

**GAIN (dB) display** - LED bargraph that indicates amount of gain being added to the sound system by the 571. In calibrate mode, the display serves as an error-condition indicator and as a prompting device.

**LEVEL SET MIN control** - Active only during calibration; sets the minimum operating level of the sound system: from 0 to -20dB.

**LEVEL SET MAX control** - Active only during calibration; sets the maximum operating level of the sound system: from 0 to +20dB.

**MODE switch** - Switches the 571's operating mode sequentially between Operate mode, Cal mode and Bypass mode, in that order.

Cal mode is indicated by the flashing Set Min or Set Max indicators in the bargraph display.

Bypass mode is indicated by the flashing bypass LED in the bargraph display.

Operate mode is indicated by the absence of flashing indicators; in this mode, the bargraph display shows gain change.

**POWER LED** - Indicates presence of AC power.

# 571

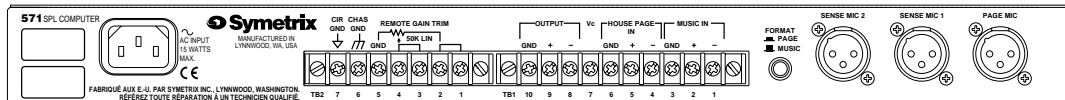

**Serial Number** - Write this number down somewhere safe, and please send us the completed warranty card.

**AC POWER INPUT** - Power cord. Connect only to appropriate AC power source. Refer to rear-panel marking for correct AC source value.

**TB2-7** - Circuit ground. Connects to the internal power supply ground.

**TB2-6** - Chassis ground. Connects to the chassis of the 571. TB2-6 and TB2-7 are connected via a 10 Ohm resistor in parallel with a 0.01 mfd capacitor.

**TB2-5 to TB2-1** - Remote gain trim connections.

*Normal usage:* Strap TB2-1 to TB2-2 and TB2-3 to TB2-4.

*Remote usage:* Remove strap between TB2-1 and TB2-2. Remove strap between TB2-3 and TB2-4. Connect a 50k Ohm, linear-taper potentiometer to TB2-2 (high side), TB2-4 (wiper), and TB2-5 (low side/ground). Be sure to connect the case of the potentiometer to TB2-5 as well. Up to 250 feet of 2-conductor shielded cable may be used to connect the remote gain control. The front-panel control is disabled by these connections.

**TB1-10 to TB1-8** - Balanced output connections.

**TB1-7** - Control voltage. This connection is the gain control voltage applied to the VCA. The scaling is: 155 mv/dB.

**TB1-6 to TB1-4** - HOUSE PAGE Input. This is a balanced line-level input to the page side of the 571.

**TB1-3 to TB1-1** - Music Input. This is a balanced line-level input to the music side of the 571. If the Page Over Music control is turned up, signals applied to either the House Page input or to the Page Mic input attenuate signals applied to the Music input.

**FORMAT PAGE/MUSIC** switch - Determines the format of the 571. In page mode, the music input is disabled.

For systems that are used for **paging only**, set this switch to the “in” position.

For systems that are used for both **music and paging**, set this switch to the “out” position.

**SENSE MIC 2** - Low-impedance, balanced input for the #2 sensing microphone. Supplies 15V phantom power. If your microphone(s) is phantom powered, refer to page 14 for additional information.

**SENSE MIC 1** - Low-impedance, balanced input for the #1 sensing microphone. Supplies 15V phantom power. If your microphone(s) is phantom powered, refer to page 14 for additional information.

**PAGE MIC** - Low-impedance, balanced input for the paging microphone. Supplies 15V phantom power. If your microphone(s) is phantom powered, refer to page 14 for additional information.

## Grounding

The 571 can be configured to conform to several different grounding conventions (float circuit, ground circuit) via connections on the rear-panel barrier strip. The factory supplied configuration has the chassis connected to the circuit ground via a 10-ohm resistor paralleled with a 0.01-mfd capacitor. The U-ground (third wire/safety ground) connection in the power cord is directly connected to the chassis.

In most installations, the factory grounding configuration works best. In some instances (high RF levels, or consultant’s specification), it may be necessary to directly connect the circuit ground to the chassis. This can be accomplished via the connections found on the terminal strip located on the rear panel.

# 571

An SPL computer monitors the ambient sound in a room, taking into account that portion of the ambient sound that is caused by the sound system. Having this information, the SPL computer uses a combination of historical data and information stored during the unit's initial calibration to determine the optimum gain setting for the sound system.

### How Does It Work?

The 571 uses a combination of analog and digital circuitry under the control of a microprocessor. The microprocessor excels at following a set of instructions and making decisions. This uses a studio-quality voltage-controlled-amplifier (VCA) that controls audio levels.

In operation, the microprocessor controls the VCA's gain based upon information gathered from the two sensing mic inputs, the paging mic input, the music input, and all of the front-panel controls. This real-time data is then compared to the data stored in memory during the calibration procedure.

In calibrate mode, the 571 acquires a history of the environment's sonic behavior. Two acoustical "snap shots" are taken, first **with the system and the environment at its minimum** operating level, and then at its maximum level. In calibrate mode, the 571 prompts the installer to set the system's minimum operating level, then its maximum operating level. By running the system for about 8 seconds at the desired minimum and maximum levels, the microprocessor gives itself time to run through a routine that develops a digitized acoustical performance history of the environment, which is automatically stored in nonvolatile memory. With this information safely stored away, the 571's sensing circuitry can differentiate between those signals originating in the sound system, and those caused by noise in the environment.

The installer sets minimum and maximum levels during calibration—the 571 "reads" the controls as they are changed, and stays in the appropriate calibration mode for about 8 seconds after the last change is made. This allows the installer time to reset operating levels as necessary.

When the system switches itself back to operate mode, the acoustical performance history acquired during calibration becomes the baseline for gain change decisions. In operate mode, the system goes about measuring environmental noise levels and internal signal levels. Because the computer has already committed to memory a sonic performance history of the room, it is able to predict what should happen, rather than to simply react to what has already happened.

### What About The Sensing Microphone?

The choice of sensing microphone is important, but it is not nearly as critical as the placement of the microphone. Internally, the sense signal passes through a bandpass filter before its level (strength) is measured. For most applications, an inexpensive low-impedance, omnidirectional microphone, such as a lavalier microphone works adequately. Some installers have used boundary microphones with good success (they're unobtrusive). Still other installers have mounted microphone cartridges (available from Mouser Electronics) inside electrical boxes equipped with a single-holed cover. For installations in smaller spaces or noisy spaces, a directional microphone is a good idea because you can use its position to optimize the performance of the system.

**Where Should I Put the Sensing Microphone?** The sensing microphone needs to "hear" the ambient sound within the controlled space. It is not necessary to put the microphone where it **only** hears the ambient sound; the 571's software can discern the difference between ambient sound caused by the sound system and that which is purely environmental.

Place the microphone(s) where it primarily hears the sounds that should determine the operating level of the sound system. In smaller rooms, use a directional microphone aimed to favor the ambient sound and to reject or minimize the sound system loudspeakers.



---

**Where Shouldn't I Put the Sensing Microphone?** Avoid the following situations:

- ❶ Placing the sensing microphone where it primarily hears the sound system.
- ❷ Placing the sensing microphone where it is within the noise field of a machine, unless you **want** the machine's noise contribution to more or less control the level of the sound system (for example, a newspaper plant in the vicinity of the printing press).
- ❸ Placing the sensing microphone(s) where the desired ambient sound source is masked by a nearby noise source (for instance, placing the sensing microphone(s) near the constant noise of the kiddie play area in a shopping mall).

### **Tips To Remember**

---

- ❶ Calibration must occur at a quiet time in the controlled space.
- ❷ It helps if you have an estimate (SPL) of the maximum level required.
- ❸ The sound system must be capable of delivering the maximum level required.
- ❹ You can learn a great deal by listening to the sensing microphones. You'll need an external microphone preamp to do this.
- ❺ You may need to create a second noncontrolled zone to prevent the sound system level from changing in spaces where the ambient conditions are stable, such as office areas or restrooms.

175

## Matching Levels vs Matching Impedances

In any audio equipment application, the question of “matching” inevitably comes up. Without digging a hole any deeper than absolutely necessary, we offer the following discussion to (hopefully) clarify your understanding of the subject.

Over the years, we have all had impedance matching pounded into our heads. This is important only for ancient audio systems, power amplifiers, and RF. Technically speaking, the reason is power transfer, which reaches a maximum when source and load are matched. Modern audio systems are voltage transmission systems and source and load matching is not only unnecessary, but undesirable as well.

Ancient audio systems operate at 600 ohms (or some other impedance value), and must be matched, both at their inputs and at their outputs. Generally speaking, if you are dealing with equipment that uses vacuum tubes, or was designed prior to 1970, you should be concerned about matching. These units were designed when audio systems were based on maximum power transfer, hence the need for input/output matching.

Power amplifiers are fussy because an abnormally low load impedance generally means a visit to the amp hospital. Thus, it’s important to know what the total impedance of the pile of speakers connected to the amplifier really is.

RF systems are matched because we really are concerned with maximum power transfer and with matching the impedance of the transmission line (keeps nasty things from happening). Video signals (composite, baseband, or otherwise) should be treated like RF.

Some folks seem to believe that balanced/unbalanced lines and impedances are related; or even worse that they are associated with a particular type of connector. Not so. Unbalanced signals are not necessarily high-impedance and balanced signals/lines are not necessarily low-impedance. Similarly, although 1/4-inch jacks are typically used for things like guitars (which are high-impedance and unbalanced), this does not predispose them to only this usage. After all, 1/4-inch jacks are sometimes used for loudspeakers, which are anything but high-impedance. Therefore, the presence of 3-pin XLR connectors should not be construed to mean that the input or output is low-impedance (or high-impedance). The same applies to 1/4-inch jacks.

So, what is really important? Signal level, and (to a much lesser degree), the impedance relation between an output (signal source) and the input that it connects to (signal receiver).

Signal level is very important. Mismatch causes either loss of headroom or loss of signal-to-noise ratio. Thus, microphone inputs should only see signals originating from a microphone, a direct (DI) box, or an output designated microphone-level output. Electrically, this is in the range of approximately -70 to -20 dBm. Line inputs should only see signals in the -10 to +24 dBm/dBu range. Guitars, high-impedance microphones, and many electronic keyboards do not qualify as line-level sources.

The impedance relation between outputs and inputs needs to be considered, but only in the following way:

**Always make sure that a device’s input impedance is higher than the output source impedance of the device that drives it.**

Some manufacturers state a relatively high-impedance figure as the output impedance of their equipment. What they really mean is that this is the minimum load impedance that they would like their gear to see. In most cases, seeing an output impedance figure of 10,000 (10K) ohms or higher from modern equipment that requires power (batteries or AC) is an instance of this type of rating. If so, then the input impedance of the succeeding input must be equal to or greater than the output impedance of the driving device.

Symetrix equipment inputs are designed to bridge (be greater than 10 times the actual source impedance) the output of whatever device drives the input. Symetrix equipment outputs are designed to drive 600-ohm or higher loads (600-ohm loads are an archaic practice that won’t go away). You don’t need to terminate the output with a 600-ohm resistor if you aren’t driving a 600-ohm load. If you don’t understand the concept of termination, you probably don’t need to anyway.



---

The two facts that you need to derive from this discussion are:

1. Match signal levels for best headroom and signal-to-noise ratio.
2. For audio, impedance matching is only needed for antique equipment and power amplifier outputs. In all other cases, ensure that your inputs bridge (are in the range of 2 to 200 times the output source impedance) your outputs.

## Signal Levels

---

The 571 is designed around studio/professional line levels: +4 dBu or 1.23 volts. The unit is quiet enough to operate at lower signal levels such as those found in semipro or musical-instrument (MI) equipment (-10 dBV or 316 millivolts).

## I/O Impedances

---

The 571 is designed to interface into almost any sound reinforcement application or background/foreground music application. This includes:

1. 600-ohm systems where input and output impedances are matched.
2. Unbalanced semiprofessional equipment applications.
3. Modern bridging systems where inputs are bridged and outputs are low source impedances (voltage transmission systems).

The 571's line input impedance is greater than 40k Ohms balanced, and greater than 40k Ohms unbalanced. The inputs may be driven from any source (balanced or unbalanced) capable of delivering at least -10 dBV into the aforementioned impedances.

## XLR Polarity Convention

---

The 571 uses the international standard polarity convention of pin 2 hot. The following chart shows the connections for each type of connector:

XLR	Tip-Ring-Sleeve	Signal
1	Sleeve	Ground
2	Tip	High
3	Ring	Low

## Input and Output Connections

---

Appendix C illustrates how to connect the 571 to various balanced and unbalanced sources.

To operate the 571's balanced line inputs from unbalanced sources, run a 2-conductor shielded cable (that's two conductors plus the shield) from the source to the 571. At the source, connect the low/minus side to the shield, these connect to the source's ground; connect the high/plus side to the source's signal connection. At the 571, the high/plus wire connects to the screw terminal marked with a "+", the low/minus wire connects to the screw terminal marked with a "-", and the shield (always) connects to screw terminal marked GND. This is preferred as it makes best use of the 571's balanced input (even though the source is unbalanced). The other alternative shown in Appendix C converts the 571's balanced input into an unbalanced input at the 571's input terminals. This works, but is more susceptible to hum and buzz than the preferred method. There is no level difference either way.

We do not recommend unbalancing the 571's microphone inputs (the sense inputs as well as the page mic input). Doing so makes these inputs considerably more susceptible to hum and induced noise. In the case of the sense microphones, it could cause problems that do not make themselves directly heard.

**Caution** 15V phantom power is applied to pins 2 and 3 on all of the 571's microphone inputs. **Never** use a mic or mic cord/adaptor that shorts pins 2 or 3 of the XLR

571

---

## Phantom Power

---

All of the microphone inputs on the 571 provide 15V phantom power for condenser microphones.

**Note** There is no external switch to turn the phantom power off. This is not likely to be a problem since 99.99% of the dynamic microphones you are likely to use with the 571 will not be harmed in any way. However, if you really do need to disconnect the phantom power from any or all of the mic inputs, please call us or a qualified service center.

## Remote Gain Trim Control

---

The output gain trim control of the 571 may be remotely located. The connection points for the remote gain trim control are terminals TB1-1 through TB1-5. These terminals are located at the rear of the 571, on the screw terminal strip labeled TB1.

For local operation, (front panel control only), terminal pairs 1 & 2 and 3 & 4 must be connected with the factory installed “U” shaped straps. These connections are required for operation of the front panel control.

For remote operation of the gain trim function, the straps must be removed. Connect a 50 kilo ohm linear taper potentiometer (pot), wired as shown on the back panel and in Figure 6-1. Up to 250 feet of 2-conductor shielded cable may be used, Be sure to connect the case of the control to the shield of the cable. The front-panel OUTPUT GAIN TRIM control is disabled once the remote gain trim control is connected.

## Grounding Options

---

The 571 can be configured to conform to several different grounding conventions via connections on the rear-panel barrier strip. The factory supplied configuration has the chassis connected to the circuit ground via a 10-ohm resistor paralleled with a 0.01-mf capacitor. The U-ground (third wire/safety ground) connection in the power cord is directly connected to the chassis.

In most installations, the factory grounding configuration works best. In some instances (high RF levels, or consultant’s specification), it may be necessary to directly connect the circuit ground to the chassis. This can be accomplished via the connections found on the terminal strip located on the rear panel.

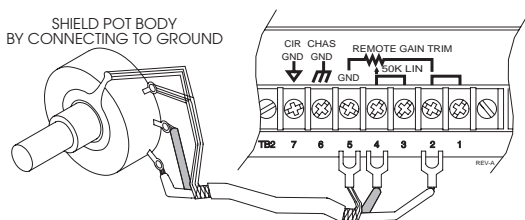

Figure 6-1. Remote gain trim control wiring.

# 571

This section is intended for more advanced users. If you are a first-time user, we recommend that you start out by using the procedure found in Chapter 3, “Setup.”

## Installation

The 571 may be installed freestanding or rack-mounted. Multiple unit installations require no additional breathing space between units.

### Installation Requirements

<b>Mechanical</b>	One rack space (1.75 inches) required, 12.5 inches depth (including connector allowance).
<b>Electrical</b>	105-125 VAC, 18 Watts maximum.
<b>Connectors</b>	Female XLR connectors for mic inputs. Pin 2 of the XLR connectors is “Hot.” All other connections are via barrier strips.

## Operating Format

The 571 has two different operating formats allowing for differences in sound system programming:

**Page** The program material sent to the 571 is paging, or pre-mixed music and paging.

**Music** The program material sent to the 571 is paging and background music, on separate lines. The 571 mixes the two signals, and ducks (reduces the volume) the music source during paging when the page over music control is set for ducking.

**Page Format** - In page format, the 571’s music input is disabled. Use this setting for page-only or pre-mixed music-page systems.

**Music Format** - In music format, the 571 monitors the signals at both the music and page inputs. Paging signals duck the music signal by the amount determined by setting of the PAGE OVER MUSIC control. Use this format when the 571 is the mixer for music and paging signals.

### Operating Mode

The 571 has three operating modes: OPERATE, CALIBRATE, and BYPASS. You access these modes by sequentially operating the MODE switch. Each push of the mode switch changes the operating mode to the next mode; the next mode after BYPASS is OPERATE.

## Bypass, Calibrate and Error Indicators

The front-panel LED bargraph also serves as a status indicator. Refer to Figure 7-1. One of the LED’s serves as the Bypass mode indicator, two others serve as error indicators.

If an error indicator flashes during calibration, the calibration procedure automatically aborts and the 571 returns to operate mode using the calibration values previously stored in non-volatile memory. The 571 cannot be recalibrated until the problem causing the error is corrected. The following explains the error indicators and the possible sources of error.

### Calibration Error Indications

*Page/Music Input Error.* Not enough program material or insufficient signal level of program material at the input of the 571.

*Sense Input Error.* Sense microphones missing or disconnected. Sense trim controls (front panel) need to be turned up.

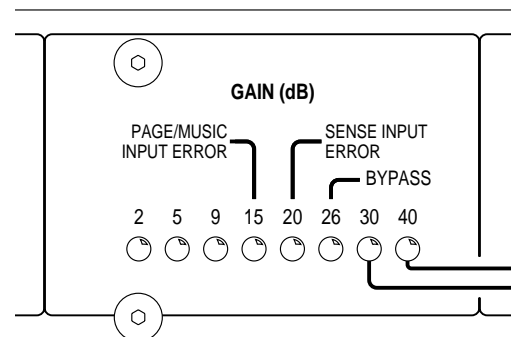

Figure 7-1. The LED Bargraph

# 571



## Block Diagram

Figure 7-2 is the block diagram for the 571. Please take a moment and take note of the following:

- All signal inputs and outputs are balanced transformerless.
- The line inputs, HOUSE PAGE IN and MUSIC IN, are unity gain.
- The mic inputs (PAGE MIC and SENSE MIC) have up to 48 dB of gain. They are equipped with 15V phantom power for condenser mics.
- All of the trim pots (page mic and sense) have stop resistors at the CCW end of their rotation which prevents them from attenuating to infinity. The range is limited to -26 dB for the PAGE MIC trimpot, and -40dB for the SENSE 1 and SENSE 2 trim pots.
- Signals on either page input operate the ducker. The ducker attenuates music signals whenever there are signals present on either page input. The PAGE OVER MUSIC control determines the amount of ducker action.
- The format switch defeats the music input and selects the source for the 571's program level detector.
- Using the remote OUTPUT GAIN TRIM control defeats the front-panel mounted control.
- Different grounding options are possible via TB2-6 and TB2-7.
- The microprocessor runs the show.

Figure 7-2. 571 block diagram.

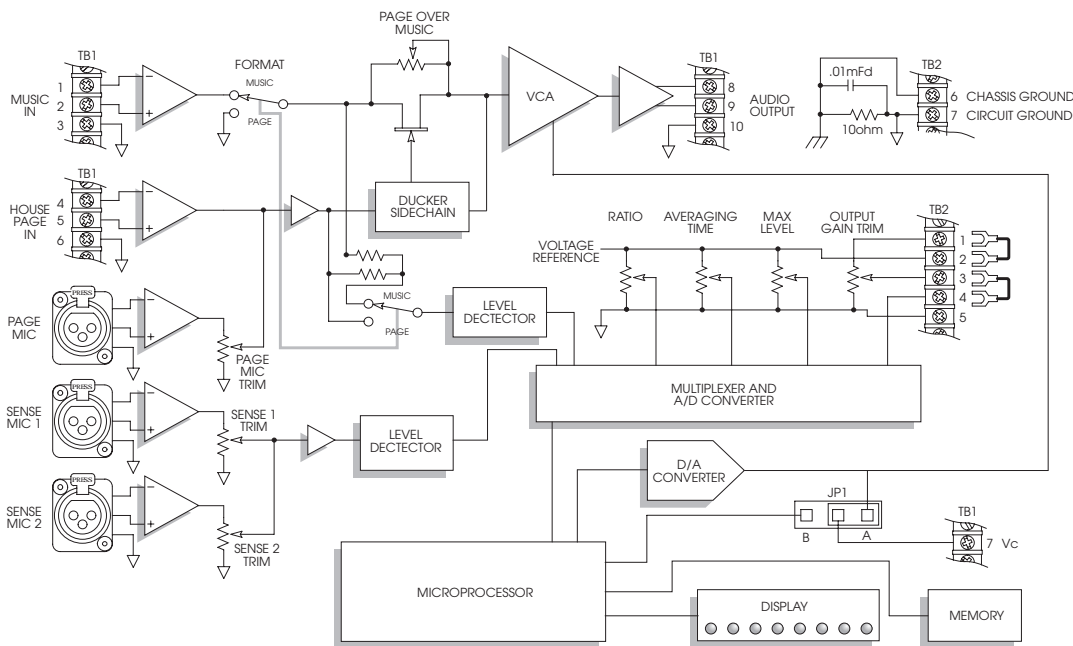

# 571

## Airports

---

The 571 is ideally suited to managing the sound pressure levels within airports. Because there is too much variation in ambient sound level within the average airport to allow one gain setting to suit all areas, we recommend that you use at least one 571 per paging zone. A typical airport installation would designate each gate as a separate paging zone, so that the sound system level at each gate would be adjusted upward as passengers gather at that gate, and then brought back down when they depart, without affecting the sound system level at the other gates.

## Train Stations and Highly Reflective Acoustic Environments

---

When using the 571 in an above-ground train station installation, many installers have had success installing one sense mic over the tracks at the end of the platform that the train will reach **first**. In the case of a subway train station installation, this sense mic would be placed over the tracks near the mouth of the tunnel from which the train will emerge. Many installers also place a second sense mic over the passenger queuing area. Use a short AVERAGING TIME control setting so that the 571 can respond quickly as trains arrive and depart.

Reflective environments, such as subway stations, can present a unique set of acoustic challenges to the sound system installer. One of these challenges can be getting correct ambient sound level information to the 571's sensing mics, so that the 571 can respond appropriately. Misinformation, such as acoustic phase coupling and cancellation, can result from a high level of reflected sound system audio reaching the 571's sensing mics.

Acoustic treatment such as Sonex™ can help in reflective acoustic environment installations. If you notice that the 571 makes inappropriate gain changes when a page is made (inappropriate increases *or* decreases in level), then you are probably having problems with misinformation in the audio that is reaching the sense mics. In this case, you **may** need to perform a modification to prevent the 571 from responding to changes in ambient level *when a page is occurring*. Please call Symetrix Technical Support at (425)-787-3222 for further information on this modification.

## Factories

---

In this application, the 571 monitors the ambient noise level within a factory and adjusts the sound system's operating level so that it is always audible. Install the sensing mics so that they receive an average of the noise sources within the space. This ensures that a loud, localized noise source will not dominate the control of the sound system. You may need to create a separate controlled zone for the loud, localized noise source by dedicating a 571, sense mic(s), speaker(s) and an amplifier to that purpose.

Speakers serving "quiet zones," such as break rooms, offices, and restrooms should probably be on their own amplifier. This amplifier could either be fed from a separate, dedicated 571, or it could be fed the same signal that appears at the *input* of the factory's 571 (so that the quiet zones are unaffected by the sound system level changes of the 571).

## Shopping Malls

---

In this application, the 571 ensures that announcements within the public spaces are always audible, but never too loud. This application requires multiple sensing mics for best results. You can connect the mics in parallel for this, however very large installations may require an external mic mixer just for the sensing mics. Be sure to reduce the mixer's output level so that it is appropriate for the 571's sensing mic inputs.

In mall applications, it's a good idea to avoid sense mic locations near localized noise sources (like the kiddie area or food courts). Like the factory application, you want the sense mics to average out all of the various noise sources within the mall. Finally, high noise areas, such as the ones previously mentioned, should be individual zones unless they are physically nearby each other.



---

## Sports Facilities

---

Sports facilities can also benefit from the 571. Typically, the 571 is used to track the ambient conditions on the concourses, other access areas, and the refreshment stands. Consider using multiple 571's to isolate specific environments from each other, such as the refreshment stands from the concourse environment.

## Race Tracks

---

Different race tracks have different noise sources. In auto racing, the cars make far more noise than the spectators. If you're going to use a 571 in a speedway installation, position the sensing mikes so they are in a good spot to pick up the cars. Since this is outdoors, some sort of weatherproof microphone is needed. A reasonable substitute is a small paging speaker, with a 70V transformer. Use a moderate transformer tap, like 10 watts. You may even be able to do away with the transformer. Tie the sense mic cable shield to the case of the speaker (or float it if it's plastic!).

In horse (and dog) racing, the spectators make more noise than the animals. In this case, position the sensing mics to pick up the spectators. If the sense mic location is sheltered, then the weatherproofing needed for auto race tracks isn't necessary, although it is a good idea to find a location and mounting arrangement that is at once people-, bird-, and rodent-proof.

## Off-Track Betting Parlors and Casinos

---

In these facilities, the crowd reaction is likely to be sudden and intense. For the betting parlor, it's a good idea to include the remote-track audio in the 571's input signal so that the unit doesn't consider it part of the crowd reaction.

In the betting parlor, use directional sensing mics placed to favor the audience. You may need to use the RATIO control to help overcome the leakage from the sound system into the sensing mics.

In casinos, be sure to place the sensing mikes up high where they hear an average of the crowd and the slot machines. Use longer averaging times.

## Restaurants, Bars & Theme Stores

---

All of these establishments have one thing in common: they all use background or foreground music as an integral part of their ambience. The volume level of the music is important: audible, but not too loud. The 571 allows management to determine the appropriate music volume level at a given ambient noise level. The 571 also helps guarantee the audibility of the music, regardless of actual conditions during operation. Again, picking the right sense mic location is the key. In a restaurant, keep it away from the kitchen and away from the entry areas. Definitely avoid espresso machines and vending machines..

In bars and lounges, several mics work better than one or two, since they help average the overall noise level of the space. Stay away from the blenders and dishwashers behind the bar. Remember that any extraneous sound sources (like the TV in a sports bar) will be regarded as extra ambient noise by the 571 and the sound system level will increase as a result. You can avoid this by running the TV audio output into the music input of the 571, so that the TV audio becomes part of the 571's program material.

## Auditoriums & Hotel Lobbies

---

Here the 571 keeps track of the ambient conditions in the outer areas such as the lobbies and foyers. If you have speakers in the rest rooms, these speakers should probably not be under the 571's control, since these areas are generally more subdued than the outer areas. Of course, the rest rooms could have their own 571.

## Museums

---

The 571 can greatly enhance the impact of automated museum exhibits. The 571 monitors the crowd, and sets the gain accordingly. If there are adjacent exhibits that also produce sound, be sure to place the sense microphone to favor the local crowd, and to reject the other exhibit.



## There is no output signal:

Check the AC power connections to the 571.

Check input and output cables and connections. Are inputs driven by outputs, and outputs driving amplifiers?

Determine that there really is a signal coming from the source and that it is getting to the 571.

Are the loudspeakers and amplifiers working?

## Unit will not calibrate:

Are input levels normal?

Are the error LEDs coming on during calibration?

Is the sensing mic(s) plugged in and turned ON?

Increase SENSE 1 and/or SENSE 2 gain.

## Music always plays too loud:

571 is being used for music, but was calibrated with the FORMAT (PAGE/MUSIC) switch in Page position. Change rear panel FORMAT (PAGE/MUSIC) switch to MUSIC, then recalibrate.

Did someone turn up the level of the music feeding the 571 after it was calibrated?

Did someone turn up the output gain trim pot?

## Unit seems to have no effect:

Check the RATIO control. At 2:1, the gain changes are *very* subtle. Turn the RATIO control clockwise for more change.

Check the AVERAGING TIME control. When this control is set other than fully counter clockwise (1.2 sec), the unit does not respond immediately.

## Unit does not increase gain sufficiently at high ambient levels:

You may be overloading the sense mic preamps. Insert 15 dB pad and recalibrate.

## PAGE/MUSIC INPUT ERROR LED flashing during calibration:

Not enough signal level on either PAGE or MUSIC inputs.

## SENSE INPUT ERROR LED flashing during calibration:

Not enough signal coming from sense mics. Try turning up the SENSE GAIN trimpots.

Check sense mics and cables.

## Hum or buzz in output:

Check input connector wiring (refer to Appendix D).

Ground loop. Check related system equipment grounding. Are all system components on the **same** AC ground?

## Distortion:

Check input signal. Is it already distorted?

Line input signal may be too hot.

Page mic signal may be too hot.

Does the sound system have sufficient power for the SPL that you are trying to attain?

If you are using a high Max setting, you may be overloading the input to your amplifier. Reduce MAX setting. Is something else clipping?

Are the amplifiers and speakers okay? Check in BYPASS.

## Noise (hiss) :

Check input signal levels, and level control settings.

Check gain settings on downstream equipment.

Is the input signal already noisy?

## No audio:

Is the unit plugged in?

Is the unit in BYPASS mode?



## 571 Specifications

**Input/Output**

Page Mic:	XLR-female, balanced low impedance, -40dBu nominal level. Phantom powered.
Sense Mics:	XLR-female, balanced low impedance, -80dBu minimum level. Phantom powered.
Music:	Screw terminals, 10k Ohm balanced bridging, -10 dBu nominal level.
House Page:	Screw terminals, 10k Ohm balanced bridging, 0dBu nominal level.
Output:	Screw terminals, +24dBm maximum into 600 Ohm balanced load. 100 Ohm source impedance.
Control Voltage output:	Unscaled drive signal to the VCA. V = -155 mV/dB
Remote Control:	Screw terminals, for 50k Ohm, linear-taper potentiometer.
CMRR:	Sense Mics: greater than 60dB @ 1 kHz Page Mic: greater than 60dB @ 1 kHz House Page (line): greater than 40dB @ 1 kHz Music: greater than 40dB @ 1 kHz
Maximum Input Levels:	Mic inputs: -30dBu Line inputs: +18dBu

**Performance Data**

Maximum Control Range:	40dB
Ambient Noise-to-Gain Ratio:	Variable, 2:1 to 1:2
Averaging Time:	1.2 seconds to 5 minutes.
Frequency Response:	20 - 20kHz +0, -1dB
Noise Floor (30 kHz bandwidth):	Better than -85dBu @ unity gain.
Distortion (THD+N):	< .05% @ 2kHz, unity gain, music input to line output.
Page Over Music:	Variable, 0 to 14 dB

**Physical**

Size (hwd), in & cm:	1.75 x 19 x 7 in 4.44 x 48.26 x 17.78 cm
Weight, lbs & kg:	7.6 lbs (3.5kg) net 10 lbs (4.6kg) shipping

**Electrical**

Power Requirements:	117V AC nominal, 105-125 VAC 50-60 Hz, 18 watts 230V AC nominal, 205-253V AC 50 Hz, 18 watts
---------------------	---

**Note:** The maximum operating ambient temperature is 25 degrees C.

In the interest of continuous product improvement, Symetrix Inc. reserves the right to alter, change, or modify these specifications without prior notice.

## 571 Architects and Engineers Specifications

The ambient noise sensing, automatic level controlling device (the device) shall regulate the operating level of a sound system in proportion to changing noise levels in the sound system's operating area. The device shall be capable of providing gain control over up to 40dB overall range, and shall be governed by a microprocessor which shall be controlled by embedded software.

The device shall vary its gain based upon measurements of the sound pressure level of ambient noise in the environment. Inputs shall be provided for up to two sensing microphones. The device shall be capable of making 215 sound pressure level measurements per second, and shall have a continuously variable Averaging Time control to cause the device to maintain a running average of those measurements for a minimum of 1.2 seconds to a maximum of 5 minutes, before using that average to compute gain adjustments.

The device shall provide inputs for paging signals at microphone level (nominal -40dBu) or line level (nominal 0dBu), and for music signals at line level (nominal -10dBu). Automatic regulation shall be selectable to apply to paging signals only (Page mode), or to apply primarily to music signals (Music mode).

In Page mode, the device shall adjust paging levels continuously with respect to ambient noise sound pressure levels. In Music mode, the device shall adjust background music levels continuously with respect to both ambient noise levels and paging activity; in Music mode, paging signals shall cause the device to attenuate music signals as determined by its Page-Over Music control, which shall be continuously variable from 0 to 14dB (ducking).

The device shall have a ratio control to vary the ambient noise-to-gain ratio continuously from 2:1 to 1:2. An output Gain Trim control shall be provided to allow overall gain to be adjusted over a 20dB range. The Output Gain trim control shall be remote controllable at a distance of up to 250 feet by the connection of a 50k Ohm variable resistor.

Calibration of the automatic level controlling device shall be semiautomatic, and shall require switching the device to CALIBRATE Mode, and adjusting the minimum desired operating level and the maximum desired operating level. Calibration settings shall be continuously maintained in nonvolatile memory without the need for battery back up power.

In addition to the various functions and general specifications mentioned above, the ambient noise sensing, automatic level controlling device shall meet or exceed the following overall performance criteria: frequency response +0,-1dB 20Hz to 20kHz, total harmonic distortion less than 0.05% at any attenuation from -40dB to 0 dB (2kHz), maximum paging microphone input level -30dBu, maximum line input level +18dBu, minimum sensing microphone input level -80dBu, maximum output level +24dBm into 600 Ohms (balanced). Minimum impedance at the microphone inputs shall be 400 Ohms, minimum impedance at the line inputs shall be 10k Ohms. The device shall be housed in an all-steel chassis designed to be mounted in a 1U (1.75") space in a standard 19" rack.

The ambient sensing automatic level controlling device shall be the Symetrix model 571 SPL Computer.



**571 Limited Warranty**

---

Symetrix, Inc. expressly warrants that the product will be free from defects in material and workmanship for one (1) year. Symetrix's obligations under this warranty will be limited to repairing or replacing, at Symetrix's option, the part or parts of the product which prove defective in material or workmanship within one (1) year from date of purchase, provided that the Buyer gives Symetrix prompt notice of any defect or failure and satisfactory proof thereof. Products may be returned by Buyer only after a Return Authorization number (RA) has been obtained from Symetrix. Buyer will prepay all freight charges to return the product to the Symetrix factory. Symetrix reserves the right to inspect any products which may be the subject of any warranty claim before repair or replacement is carried out. Symetrix may, at its option, require proof of the original date of purchase (dated copy of original retail dealer's invoice). Final determination of warranty coverage lies solely with Symetrix. Products repaired under warranty will be returned freight prepaid by Symetrix via United Parcel Service (surface), to any location within the Continental United States. At Buyer's request the shipment may be returned via airfreight at Buyer's expense. Outside the Continental United States, products will be returned freight collect.

**The foregoing warranties are in lieu of all other warranties, whether oral, written, express, implied or statutory. Symetrix, Inc. expressly disclaims any IMPLIED warranties, including fitness for a particular purpose or merchantability. Symetrix's warranty obligation and buyer's remedies hereunder are SOLELY and exclusively as stated herein.**

This Symetrix product is designed and manufactured for use in professional and studio audio systems and is not intended for other usage. With respect to products purchased by consumers for personal, family, or household use, Symetrix **expressly disclaims all implied warranties, including but not limited to warranties of merchantability and fitness for a particular purpose.**

This limited warranty, with all terms, conditions and disclaimers set forth herein, shall extend to the original purchaser and anyone who purchases the product within the specified warranty period.

Symetrix does not authorize any third party, including any dealer or sales representative, to assume any liability or make any additional warranties or representation regarding this product information on behalf of Symetrix.

This limited warranty gives the buyer certain rights. You may have additional rights provided by applicable law.

**Limitation of Liability**

---

The total liability of Symetrix on any claim, whether in contract, tort (including negligence) or otherwise arising out of, connected with, or resulting from the manufacture, sale, delivery, resale, repair, replacement or use of any product will not exceed the price allocable to the product or any part thereof which gives rise to the claim. In no event will Symetrix be liable for any incidental or consequential damages including but not limited to damage for loss of revenue, cost of capital, claims of customers for service interruptions or failure to supply, and costs and expenses incurred in connection with labor, overhead, transportation, installation or removal of products or substitute facilities or supply houses.

**571**

---

## Servicing the 571

---

If you have determined that your 571 requires repair services and you live *outside* of the United States please contact your local Symetrix dealer or distributor for instructions on how to obtain service. If you reside in the U.S. then proceed as follows:

At the Symetrix factory, Symetrix will perform in-warranty or out-of-warranty service on any product it has manufactured for a period of five years from date of manufacture.

**Before sending anything to Symetrix**, contact our Customer Service Department for a return authorization (RA) number. The telephone number is (425) 778-7728, Monday through Friday, 8AM (800 hours) though 4:30 PM (1630 hours), Pacific Time.

## In-warranty Repairs

---

To get your 571 repaired under the terms of the warranty:

1. Call us for an RA number.
2. Pack the unit in its original packaging materials.
3. Include your name, address, daytime telephone number, and a brief statement of the problem.
4. Write the RA number on the outside of the box.
5. Ship the unit to Symetrix, freight prepaid.

**We do *not* accept freight collect shipments.**

Just do these five things, and repairs made in-warranty will cost you only one-way freight charges. We'll prepay the return (surface) freight.

If you choose to send us your product in some sort of flimsy packaging, we'll have to charge you for proper shipping materials. If you don't have the factory packaging materials, then do yourself a favor by using an oversize carton, wrap the unit in a plastic bag, and surround it with bubble-wrap. Pack the box full of Styrofoam peanuts. Be sure there is enough clearance in the carton to protect the rack ears (you wouldn't believe how many units are returned with bent ears). We won't return the unit in anything but Symetrix packaging for which we will have to charge you. Of course, if the problem turns out to be operator inflicted, you'll have to pay for both parts and labor. In any event, if there are charges for the repair costs, you will pay for the return freight. All charges will be COD unless you have made other arrangements (prepaid, Visa or Mastercard).

## Out-of-warranty Repairs

---

If the warranty period has passed, you'll be billed for all necessary parts, labor, packaging materials, and freight charges. Please remember, you must call for an RA number before sending the unit to Symetrix.



Circumstances occasionally prevent the installer from calibrating the 571 in a quiet environment, even though it may be known that the ambient noise does, in fact, sometimes fall to a known value. To artificially create the input level that would be seen by the 571 when the room is at its quietest, place an in-line pad in the sensing microphone input(s).

For example: a factory environment runs at 92 dBA continuously. Occasionally the ambient SPL drops to 67 dBA. This represents a difference of 25 dB. Prior to calibration, insert a 25 dB in-line pad into the microphone line. Perform the calibration procedure, with the SET LEVEL MIN and SET LEVEL MAX controls set for an output level range of at least 25 dB. When calibration is complete, remove the pad.

Assuming that the 571 were operating at a ratio of 1:1, the gain would go up 25 dB when the pad was removed. Conversely, the gain would, as a result, be able to go down 25 dB when the noise dropped. Without the use of the pad during calibration, the 571 would never know that the ambient noise level could go that low. As a result, its operating range would have been seriously restricted.

For safety installations that require the system to operate at a specific minimum and maximum SPL, use a sound level meter in the environment during the calibration procedure. Simply adjust the SET LEVEL MIN and SET LEVEL MAX controls to deliver the output level required to develop the specified SPLs.

**Note** When a minimum operating level is specified, do not allow user control of the OUTPUT GAIN TRIM function. Although the 571 will never allow signals to go above the set maximum, it will allow signals below the set minimum if the OUTPUT GAIN TRIM is set below "0".

# 571



For multichannel, stereo, or other special applications, a slave unit to the 571 is available. The 571S contains only the analog circuitry found in a 571 “master” SPL Computer.

The 571S is intended to be operated as the second channel in a stereo system, and for unusual installations requiring sub-control or time delayed control of the audio signal’s level.

The 571S Slave unit connects to the 571 SPL Computer by connecting its terminal labeled  $V_c$  to the terminal labeled  $V_c$  on the master, as shown below. Use shielded cable and keep the wiring as short and direct as possible. We recommend that the master and slave be mounted together in the same equipment rack.

Audio connections to the 571S are exactly like those to the 571, except that in the case of stereo operation, they are normally from, and to, the other channel. If paging is used, connect the paging line level feed to both the master and slave using a y-cord or jumper.

The rear panel FORMAT (PAGE/MUSIC) switch **must** be set to the appropriate position. Refer to Chapter 7 for specifics.

The only front panel control on the 571S is the PAGE-OVER MUSIC control. If the PAGE-OVER MUSIC control on the 571 master unit is used to provide “ducking” of the music during paging announcements, set the corresponding control on the 571S to the same position.

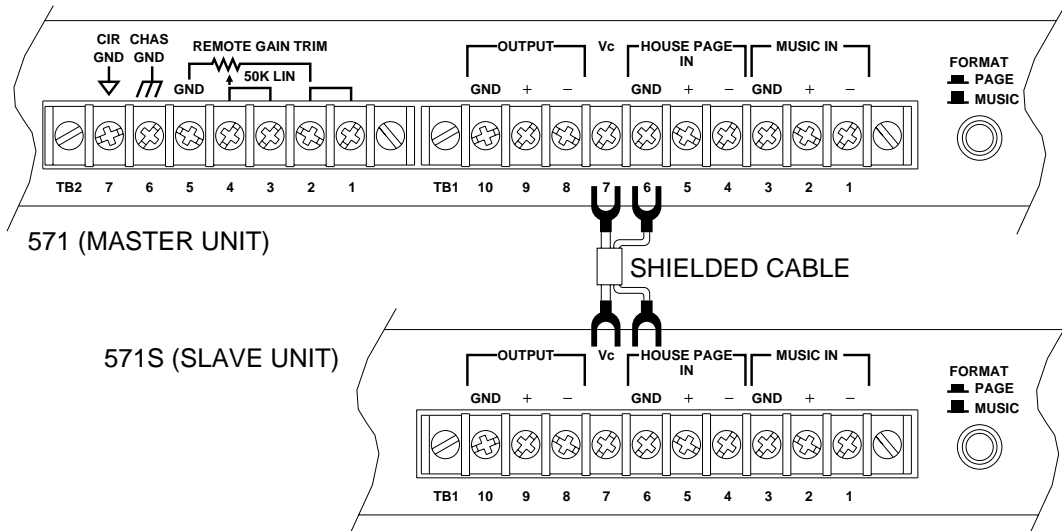
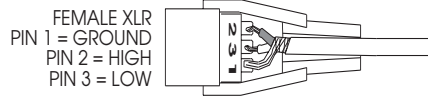

Figure B-1. 571S hookup.



Input and output connector wiring. These diagrams represent the majority of connectors used in modern audio equipment. Locate the source connector in the left column and match it up with the destination connector in the right column. Wire your cable according to the diagrams.

### FROM BALANCED OUT



### TO BALANCED IN

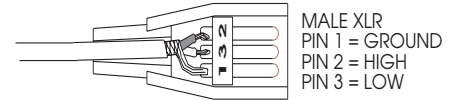

### FROM BALANCED OUT

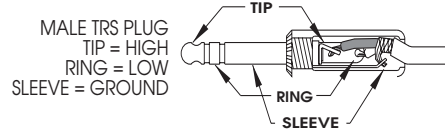

### TO UNBALANCED IN FROM TRANSFORMER COUPLED OR FLOATING BALANCED OUTPUT

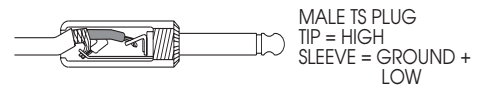

### FROM UNBALANCED OUT

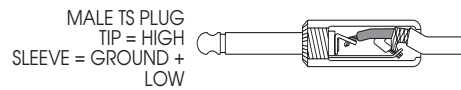

### TO BALANCED IN

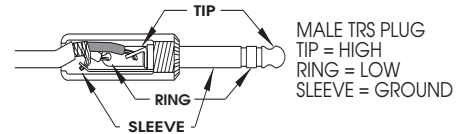

### FROM BALANCED OUT

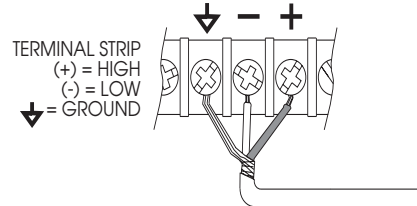

### TO BALANCED IN

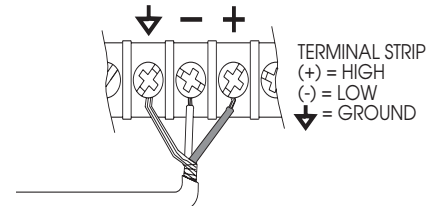

### FROM UNBALANCED OUT

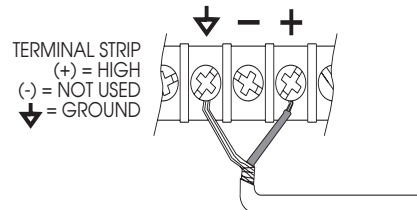

### FROM NON-TRANSFORMER (ELECTRONIC) BALANCED OUTPUT (TYPICAL OF SYMETRIX PRODUCTS)

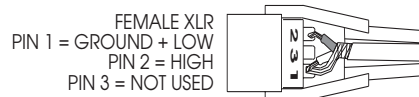

### TO UNBALANCED IN

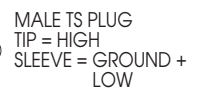

REV-B

# 57

**Declaration of Conformity**

We, Symetrix Incorporated, 6408 216th St. SW, Mountlake Terrace, Washington, USA,  
declare under our sole responsibility that the product:

**571 SPL Computer**

to which this declaration relates, is in conformity with the following standards:

**EN 60065**

**Safety requirements for mains operated electronic and related  
apparatus for household and similar general use.**

**EN 50081-1**

**Electromagnetic compatibility - Generic emission standard  
Part 1: Residential, commercial, and light industry.**

**EN 50082-1**

**Electromagnetic compatibility - Generic immunity standard  
Part 1: Residential, commercial, and light industry.**

The technical construction file is maintained at:

**Symetrix, Inc.**

6408 216th St. SW  
Mountlake Terrace, WA, 98043  
USA

The authorized representative located within the European Community is:

World Marketing Associates  
P.O. Box 100  
St. Austell, Cornwall, PL26 6YU, U.K.

Date of issue: 1 November 1995

Place of issue: Mountlake Terrace, Washington, USA

Authorized signature: \_\_\_\_\_

  
Dane Butcher, President, Symetrix Incorporated.



571

 **Symetrix**



**Symetrix, Inc.**

6408 216th St. SW

Mountlake Terrace, WA, 98043

USA

Tel: (425) 778-7728

Fax: (425) 778-7727

Website: <http://www.symetrixaudio.com>

Email: [symetrix@symetrixaudio.com](mailto:symetrix@symetrixaudio.com)