

PMDX-122

Bi-Directional Break-Out Board

User's Manual

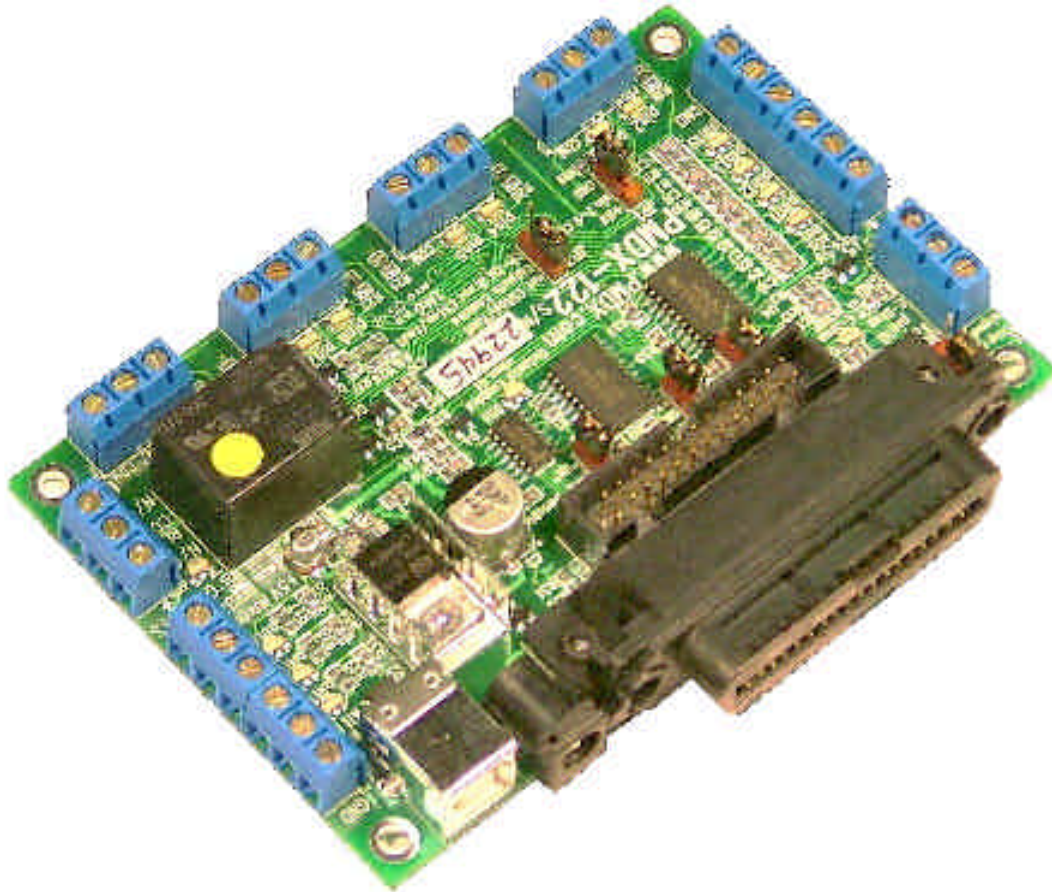

Document Revision: 1.8
Date: 30 April 2007
PCB Revision: PCB-450B and PCB-450C
Serial Numbers: 23110 and above

PMDX
9704-D Gunston Cove Rd
Lorton, VA 22079-2366 USA

Web: <http://www.pmdx.com>
Phone: +1 (703) 372-2975
FAX: +1 (703) 372-2977

Table of Contents

1.0	Overview	3
1.1	Important Safety Information	3
1.2	Warranty Summary.....	3
1.3	Trademarks	3
1.4	Features.....	4
1.5	Differences Between the PMDX-122 and the PMDX-121	4
1.6	Updates to this Manual	4
2.0	Quick Setup Guide	5
2.1	Example with Mach2/3, Charge Pump and Gecko Drivers.....	5
2.2	Example with Mach2/3, Charge Pump and PMDX-150 Stepper Drivers.....	6
2.3	Example with Logic Level Stepper Drivers.....	7
2.4	Example Limit Switch Wiring	7
3.0	Functional Description and Block Diagrams	8
3.1	Data Bus.....	8
3.1.1	Data Bus Signals.....	9
3.1.2	Data Bus Common	10
3.1.3	Data Bus Buffer Enable	10
3.1.4	Data Bus Buffer Direction.....	11
3.2	Control Outputs.....	11
3.2.1	Control Outputs Enabled Jumper and LED.....	12
3.2.2	General Purpose Outputs and LEDs.....	13
3.2.3	Pin 17 Output.....	13
3.2.4	Relay Control and LED (pin 1)	14
3.3	Status Inputs.....	14
3.4	Fault and E-Stop Inputs	15
3.4.1	Fault Input	17
3.4.2	E-Stop Input	17
3.4.2.1	E-Stop Input as "E-Stop" Signal	17
3.4.2.2	E-Stop Input as General-Purpose Input	17
3.4.2.3	"E-Stop" LED (DS10).....	18
3.5	Charge Pump (watchdog).....	18
4.0	Summary of Connector Pinouts	18
4.1	Data Bus Connectors (J1, J2, J3, and J4)	19
4.2	Status Input Connector (J5).....	19
4.3	Fault and E-Stop Connector (J6)	20
4.4	Relay Contact Connector (J7)	20
4.5	Control Output Connector (J8).....	21
4.6	PC Parallel Port Connectors (J10 & J9).....	21
4.7	Power Supply Connector (J11).....	23
4.8	USB Connector (J12).....	23
5.0	Summary of Jumper Configurations	23
6.0	Summary of LEDs	26
7.0	Advanced Configurations	27
7.1	Configuring a PMDX-122 to Emulate a PMDX-121	27
7.2	Example Daisy-Chain PMDX-122 with Encoder Inputs	27
8.0	Mechanical Specifications	29
9.0	Electrical and Environmental Specifications	30
Appendix A	– Warranty	31

1.0 Overview

This document describes the configuration and operation of the PMDX-122 Bi-Directional Break-Out Board. The PMDX-122 provides an interface between a PC and a multi-axis stepper motor system or other user equipment. This document pertains to the following versions of the PMDX-122:

Circuit Board Revision: PCB-450B and PCB-450C (marked on the bottom of the board)
Serial Number Range: 23110 and above

1.1 Important Safety Information

The PMDX-122 is intended for integration by the purchaser into industrial control systems. It is solely the purchaser's responsibility to assure that the system is configured in a manner consistent with applicable safety requirements. Practical Micro Design, Inc. does not control how this board is integrated into the purchaser's system and cannot be responsible for guaranteeing the safety of your system.

The PMDX-122 is not guaranteed to be fail-safe. The system into which the PMDX-122 is installed should provide fail-safe protection and emergency stop capability.

The PMDX-122 contains circuitry that may be connected to dangerous voltages. Care must be taken that user cannot come in contact with these voltages. An enclosure that allows for modest ventilation, but prevents intrusion by operator's hands and foreign objects, especially conductive byproducts of machining operations, should be utilized with this board. Interlock switches on power circuits should remove power when the enclosure is opened.

Automated machine tools, into which the PMDX-122 may be integrated, can cause injury. Precautions should be taken to assure that operators are trained in their proper operation and safety procedures, and that they are protected from moving parts that may be under remote control and may move unexpectedly.

This product may not be used in life support or other critical safety applications.

1.2 Warranty Summary

The PMDX-122 is warranted against failure due to defective parts or workmanship for 90 days from the date of sale. Refer to Appendix A for complete warranty details.

If you have an item requiring service, please see the support page on the PMDX web site (<http://www.pmdx.com>) for return instructions.

The purchaser must pay shipping to return the unit to PMDX. We will ship the repaired unit back to you via ground transportation at our expense. Repairs are normally completed within 10 business days. See Appendix A for our complete warranty details.

1.3 Trademarks

The following product names used in this manual are the trademark, tradename or registered mark of the respective companies:

<u>Product Names</u>	<u>Company</u>
G201, G202, G210, G212, G320, G340 and Geckodrive	Geckodrive, Inc. (http://www.geckodrive.com)
Mach2 and Mach3 (note that this document uses "Mach2/3" to refer to either 'Mach2" or "Mach3")	ArtSoft Software Inc. (http://www.artofcnc.com)
PMDX-121, PMDX-122, PMDX-150	PMDX/Practical Micro Design, Inc. (http://www.pmdx.com)

1.4 Features

The PMDX-122 has the following features:

PC Parallel Port:

- Buffers signals to/from the PC parallel port
- Allows use of all 8 data bits, 4 control outputs and 5 status inputs
- Centronics cable connector uses standard PC printer cable

Status Inputs:

- 5 each status inputs w/pull-up resistors
- Status signals are buffered
- LED indicators for each input

Relay Contact Outputs:

- Isolated relay with N.O and N.C terminals
- LED indicator for relay state

General Purpose Outputs:

- 3 each general purpose digital outputs
- Outputs are buffered
- LED indicator for each output

Power Supply Input:

- +7 to +12 VDC **or** 9 VAC input via 2.1mm coaxial jack
- Or alternate +5V DC via USB connector
- Or alternate +7 to +12 VDC **or** 9 VAC input via J8 screw terminal connector

Data Bus (Step/Direction signals):

- 4 axes of step and direction or 8 general purpose signals
- Data bus signals are buffered
- Bi-directional data bus (outputs or inputs)
- Can supply +5V to motor driver opto-couplers or a ground reference for logic inputs

Special Features:

- Wire clamp screw terminals for all connections to data bus signals, relay and control outputs, and status inputs
- Auxiliary +5 volt supply output

1.5 Differences Between the PMDX-122 and the PMDX-121

The PMDX-122 is a replacement (and upgrade) to the PMDX-121 board. For directions on configuring the PMDX-122 to function like a PMDX-121, see section 7.1. The differences between the PMDX-121 and PMDX-122 are:

- The PMDX-122 supports bi-directional data on J1, J2, J3 and J4 (the PC parallel port's data bus). The PMDX-121 only supported "output from the PC".
- The PMDX-122's data outputs (on J1, J2, J3 and J4) always have pull-up resistors. The PMDX-121's data outputs could have pull-up or pull-down resistors depending on the how JP1 was configured.
- The PMDX-122 supports using the *E-Stop* input as a general-purpose input without affecting the data and control outputs (see section 3.4.2.2). On the PMDX-121, the *E-Stop* input always affected the data and control outputs.
- The PMDX-122 supports daisy-chaining from another PMDX-122 or a PMDX-121, with the "charge pump" on the first board able to disable the data and control outputs on the daisy-chained PMDX-122 board (see section 7.2 for an example). The PDMX-121 did not support this feature.

1.6 Updates to this Manual

Check the PMDX web site for revisions or updates to this manual (<http://www.pmdx.com>). The latest revision of this manual is available on the PMDX-122 page (follow the links from the main page).

2.0 Quick Setup Guide

2.1 Example with Mach2/3, Charge Pump and Gecko Drivers

Figure 1 on page 6 shows a standard configuration using Mach2 (or Mach3) software on the PC driving the PMDX-122. The PMDX-122 is in turn connected to opto-isolated stepper drivers, such as the GeckoDrive units, that require a voltage source on their "common" terminal (see note below). ***Not all opto-isolated stepper drivers require a voltage source on their "common" terminal. Verify they style of opto-couplers on your stepper drivers before connecting them to the PMDX-122.*** The PMDX-150, for example, requires a ground on the "common" terminal (see section 2.2).

NOTE – Some GeckoDrive models require the use of +5V on their "common" terminal (G201, G202 and G320, for example), while other models provide a jumper to select either +5V or ground as the "common" reference (G210, G212, G340, for example). We recommend always using "+5V" for the "common" reference on GeckoDrive models.

This configuration takes advantage of Mach2/3's "charge pump" facility so that the PMDX-122 disables all of its outputs if the PC stops "behaving properly" (i.e. servicing the charge pump). Mach 2/3 must be set to provide the step and direction signals to the data port pins that match your wiring configuration. We recommend the connections as shown in Figure 1, and listed in Table 1. Mach 2/3 must also be set to run the charge pump signal on pin 17. If you do not wish to use the charge pump feature, change jumper JP3 to the "not EStop/Fault" position.

The significant jumpers for this configuration are JP1, JP2, JP3 and JP5. The other jumpers (JP4 and JP6) may be changed to suit your application. As configured in Figure 1, the *Fault* input defaults to "no fault" and may be left unconnected if not used. To activate the *Fault* input, connect it to ground (not shown).

PC Parallel Port Pin #	Function
2	X axis Direction
3	X axis Step
4	Y axis Direction
5	Y axis Step
6	Z axis Direction
7	Z axis Step
8	A axis Direction
9	A axis Step

Table 1 – Mach2/3 Step and Direction Configuration

WARNING: *Do not use this configuration with non-isolated stepper drivers. Doing so may damage the stepper drivers and the PMDX-122. For non-isolated drivers see section 2.2.*

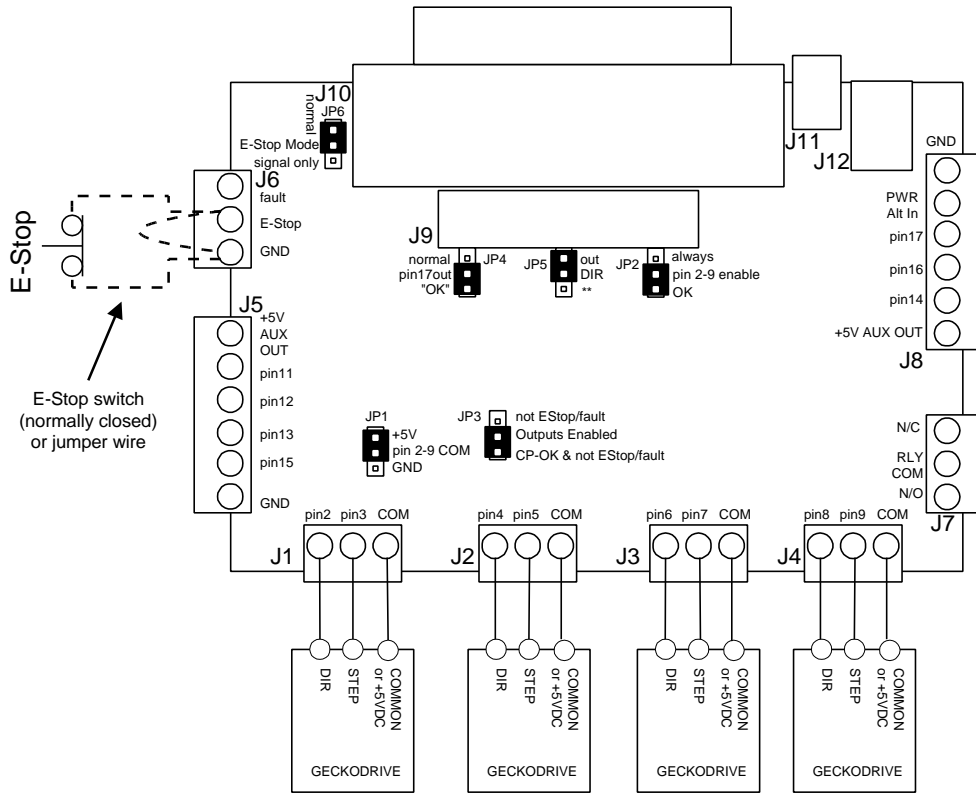

Figure 1 - Configuration w/Mach2/3, charge pump and Gecko stepper motor drivers

2.2 Example with Mach2/3, Charge Pump and PMDX-150 Stepper Drivers

Figure 2 shows a standard configuration using Mach2 (or Mach3) software on the PC driving the PMDX-122. The PMDX-122 is in turn connected PMDX-150 stepper drivers, which have opto-couplers that require a ground reference on their "common" terminal. **Not all opto-isolated stepper drivers require a ground reference on their "common" terminal. Verify they style of opto-couplers on your stepper drivers before connecting them to the PMDX-122.**

This configuration takes advantage of Mach2/3's "charge pump" facility so that the PMDX-122 disables all of its outputs if the PC stops "behaving properly" (i.e. servicing the charge pump). Mach 2/3 must be set to provide the step and direction signals to the data port pins that match your wiring configuration. We recommend the connections as shown in Figure 2, and listed in Table 1 (on page 5). Mach 2/3 must also be set to run the charge pump signal on pin 17. If you do not wish to use the charge pump feature, change jumper JP3 to the "not EStop/Fault" position.

The significant jumpers for this configuration are JP1, JP2, JP3 and JP5. The other jumpers (JP4 and JP6) may be changed to suit your application.

As configured in Figure 2, the *Fault* input defaults to "no fault" and may be left unconnected if not used. To activate the *Fault* input, connect it to ground. When using PMDX-150 stepper drivers, connect their "Fault" outputs together and connect that to the PMDX-122's *Fault* input as shown. This allows the fault output of any PMDX-150 to disable the other PMDX-150 drivers, disable the PMDX-122's outputs and signal the fault to the PC via pin 10 (the \sim Ack signal).

NOTE - This configuration should also be used for stepper drivers that have logic level step and direction inputs (also called "TTL" or "CMOS" inputs). The "Fault" input may or may not be used, depending on the features of the stepper drivers.

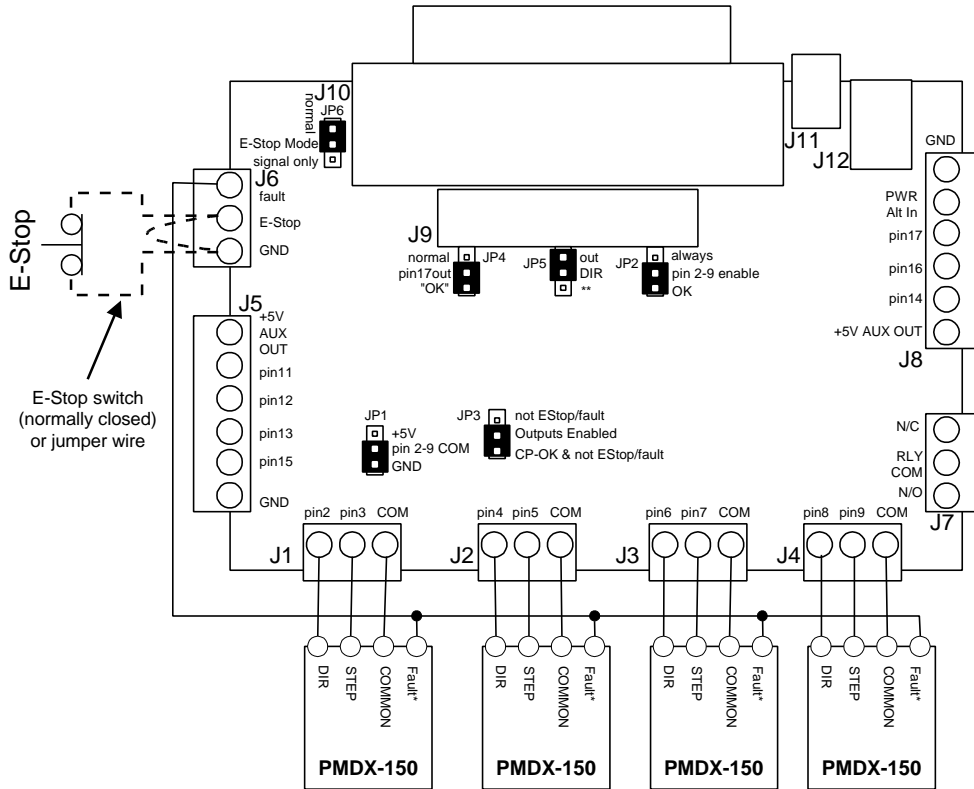

Figure 2 - Configuration w/Mach2/3, charge pump and PMDX-150 stepper drivers

2.3 Example with Logic Level Stepper Drivers

Stepper drivers with logic level inputs (also called "TTL" or "CMOS" inputs) connect to the PMDX-122 in the same manner as the PMDX-150. See section 2.2, *Example with Mach2/3, Charge Pump and PMDX-150 Stepper Drivers*.

2.4 Example Limit Switch Wiring

Mechanical switches, in either "normally open" or "normally closed" configurations, or optical interrupter switches can be used to provide input signals to the PMDX-122. These switches can act as limit switches, home indicators or other status information. Since the PMDX-122 provides pull-up resistors on the status inputs (see section 3.3), mechanical switches can be wired directly to the signal pins on J5 and ground. Optical interrupter switches require a current-limit resistor for the emitter LED. Note that the examples below show the signals connected to "pin 11". The input signals may be connected to any of the signal pins on J5. The input signals may also be connected to the "E-Stop" input on J6 when the "E-Stop" input is configured as a general-purpose input (see section 3.4.2.2).

Normally Closed Switches

The left-hand drawing in Figure 3 shows an example of "normally closed" mechanical switches. The switches are wired in series so that the "normal" case is ground (logic low) going into pin 11 of the PC's parallel port. When one or more of the switches open, the pull-up resistor on the PMDX-122 provides a

logic high into pin 11 on the PC's parallel port. Any number of "normally closed" switches may be connected in series to a single input terminal on the PMDX-122.

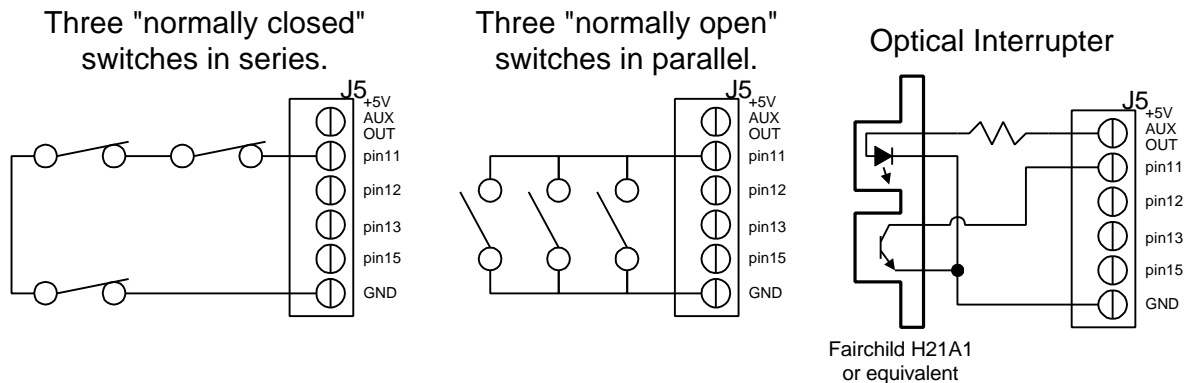

Figure 3 – Example Switch and Optical Interruptor Configurations

Normally Open Switches

The center drawing in Figure 3 shows an example of "normally open" mechanical switches. The switches are wired in parallel so that the "normal" case is +5V (logic high) going into pin 11 of the PC's parallel port (due to the pull-up resistor on the PMDX-122). When one or more of the switches close, a logic low appears on pin 11 on the PC's parallel port. Any number of "normally open" switches may be paralleled onto a single input terminal on the PMDX-122.

Optical Interrupter

The right-hand drawing in Figure 3 shows an example of an optical interrupter. This example uses the "+5V Aux Out" from the PMDX-122 to power the emitter LED. Choose a resistor value to provide the desired LED current (refer to the data sheet for the optical interrupter). The output transistor is connected as an "open collector" output between the PMDX-122 input pin and ground. When light from the LED strikes the sensor transistor, the transistor conducts giving a logic low on pin 11 of the PC's parallel port. Then the LED is "interrupted", the transistor stops conducting and the PMDX-122's pull-up resistor gives a logic high on pin 11.

3.0 Functional Description and Block Diagrams

3.1 Data Bus

The PC parallel port contains an 8-bit data bus. On older PCs, this data bus was "output only." On newer PCs, the data bus is bi-directional and can switch from "output" to "input" under software control. The PMDX-122 buffers the data bus signals between the PC and the PMDX-122's connectors J1 through J4. The PMDX-122 supports the bi-directional data bus, where the PMDX-122's data direction is jumper selectable to "output only", "input only" or "controlled by the '~Select In' control signal." See section 4.1 for more information on the data bus connectors.

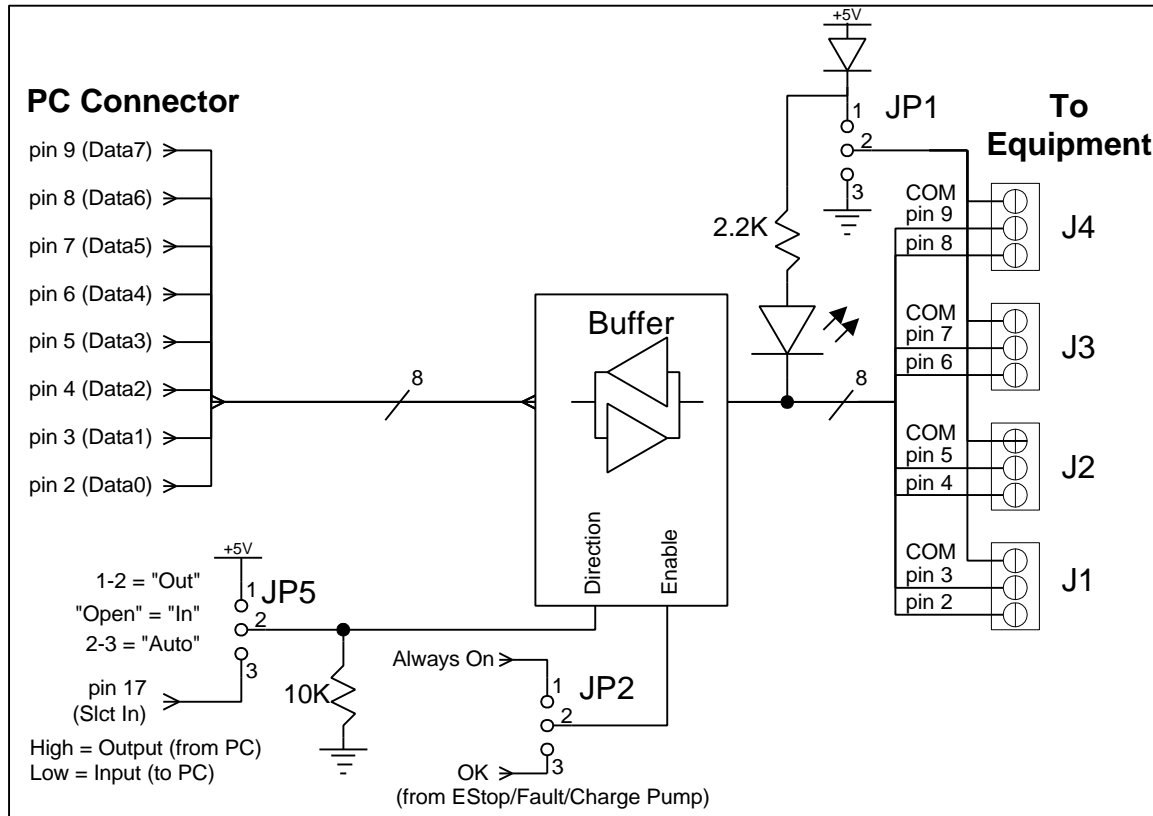

Figure 4 - Block diagram of Data Bus Circuitry

3.1.1 Data Bus Signals

Connectors J1 through J4 contain buffered versions of the PC parallel port "data bus" signals. These connectors are labeled to denote which pin on the PC's parallel port 25-pin "D" connector is associated with each terminal. "Pin 2" is data bus bit "D0" (the least-significant bit) and "Pin 9" is data bus bit "D7" (the most-significant bit).

The data bus signals are normally used for step and direction outputs. However, they can also be used as general-purpose output or input signals. The data bus signals must be either all outputs, or all inputs. It is not possible to have some as outputs and some as inputs.

Each data bus signal has a pull-up resistor and an LED that is "on" when the signal is driven low. The signals can be driven low by the PC when the data bus is in "output" mode, or by the external equipment when the data bus is in "input" mode (see section 3.1.4).

The pull-up resistors serve several purposes:

1. When the data bus direction is set to "output" (i.e. from the PC), and the buffer has been disabled via the *E-Stop* input, *Fault* input or a "charge pump" failure, the pull-up resistors provide a default logic "high" voltage level at the connectors (see note below regarding the actual voltage present when then outputs are disabled).
2. When the data bus direction is set to "input" (i.e. to the PC), the data inputs to the PMDX-122 can be driven by mechanical switches to ground or by encoders or other devices with open-collector outputs.

3. When the data bus direction is set to "input" (i.e. to the PC), the pull-up resistors provide a default logic "high" input voltage to the PMDX-122's data bus buffer when there is no signal source driving that data signal from the connectors.

Note that the voltage present on J1 through J4 when the buffer is tri-stated is approximately 3.2V. This is due to the voltage drop across the protection diode and the LED.

3.1.2 Data Bus Common

The PMDX-122 provides a common reference signal on the four data bus connectors (J1, J2, J3 and J4). This common signal is the same for all four connectors and is jumper selectable between a nominal +5V or ground. Jumper JP1 (labeled "pin 2-9 COM" on the circuit board) determines this voltage reference as follows:

Setting	Label	Description
1 to 2	+5V	Supplies an nominal +5V to the common terminals on J1, J2, J3 and J4. This configuration is commonly used when the motor drivers have optically isolated inputs that expect a voltage source on their "common" terminal (such as some of the GeckoDrive modules). In this case, the PMDX-122 supplies the +5V power to the opto-couplers. See the note and warning below.
2 to 3	GND	Connects the PMDX-122's ground to the common terminals. This setting would typically be used with motor drivers that have optically isolated inputs that expect a ground reference on their "common" terminal (such as the PMDX-150). It can also be used with motor drivers or general-purpose logic signals that have non-isolated, TTL or CMOS logic style inputs.

Table 2 – "Pin 2-9 Common" Jumper Settings (JP1)

The PMDX-122 has a protection diode between its +5V supply and the common terminals (see Figure 4). This prevents any voltages that are accidentally applied to the common terminals from damaging the PMDX-122. A side effect of this diode is that the "+5V" that appears on the common terminals is less than +5V. The actual voltage depends on the PMDX-122's power source. For AC or DC power via J11, the voltage is approximately 4.2V. When using the USB connector for power, the voltage *may* be slightly lower than 4.2V, depending on several factors, including length of the USB cable and total load on the USB hub (see sections 4.8 and 9.0 for USB hub requirements). These voltages are sufficient to drive external opto-isolators.

WARNING: *When connecting to non-isolated motor driver inputs you must use the "ground" setting on jumper JP1. Do not connect the PMDX-122's "+5V" reference to ground on the motor driver module. Doing so may damage the buffers on the PMDX-122 and the inputs to the motor drivers.*

NOTE – Changing the common reference from "+5V" to "Gnd" (via jumper JP1) when feeding optically isolated driver inputs has the effect of inverting the step and direction signals.

3.1.3 Data Bus Buffer Enable

The PMDX-122 allows the *E-Stop*, *Fault* and charge pump circuits to disable the data bus buffers. Jumpers JP2 and JP3, determine if and when the data bus buffers will be disabled. Section 3.1.1, *Data Bus Signals*, describes behavior of the data bus signals when they are disabled. See section 3.2.1 for information on configuring jumper JP3. Jumper JP2 is labeled "pin 2-9 enable" on the circuit board, and can be configured as follows:

Setting	Label	Description
1 to 2	always	The data bus buffers are always enabled (i.e. ignore the <i>E-Stop</i> , <i>Fault</i> and charge pump circuits)
2 to 3	OK	Data bus buffers are enabled as long as the "Outputs Enabled" LED is "on". Note that this setting uses the "OK" signal from jumper JP3 (see section 3.2.1, <i>Control Outputs Enabled Jumper and LED</i> for more information).

Table 3 – "Pin 2-9 Enable" Jumper Settings (JP2)

3.1.4 Data Bus Buffer Direction

Jumper JP5 determines the direction of the PMDX-122's data bus buffer. The data bus is configured as input or output for the entire data bus. The direction of individual bits cannot be controlled.

Setting	Label	Description
1 to 2	out	The data buffers are configured as "output" buffers (from the PC out through the PMDX-122).
2 to 3	**	The data buffer direction is dynamically controlled by the " <i>~Select In</i> " signal from the PC's parallel port (pin 17 on the 25-pin "D" connector) as follows: Logic High Data buffers are "output" (from the PC) Logic Low Data buffers are "input" (to the PC) Note that the " <i>~Select In</i> " signal also drives the "charge pump" function. If you are using " <i>~Select In</i> " for direction control, make sure to disable the charge pump function (see section 3.2.1). See the note and warning below.
Open (jumper not installed)		The data buffers are configured as "input" buffers (through the PMDX-122 into the PC). See the note and warning below.

Table 4 – Data Bus Direction Jumper Settings (JP5)

WARNING: *When jumper JP5 is configured so that the data bus direction is either "input" or "~Select In" controlled, jumper JP2 should be set to "always enabled". There are no pull-up or pull-down resistors on the PC side of the data bus buffers. If the data buffers are configured as "input to PC" and then disabled, the PC's parallel port will have floating inputs which could result in erratic readings.*

NOTE – In order to use the data lines as inputs to a PC, the PC's BIOS must be set so that the parallel port is configured as either "bi-directional", "EPP" or "ECP". Please consult your PC's documentation for instructions on how to change your BIOS settings.

3.2 Control Outputs

The PMDX-122 supports three general-purpose control outputs, as shown in Table 16 on page 21. The fourth PC parallel port control signal (*~Strobe*) is dedicated to the PMDX-122's on-board relay (see section 3.2.4). Figure 5 shows a block diagram of the control outputs.

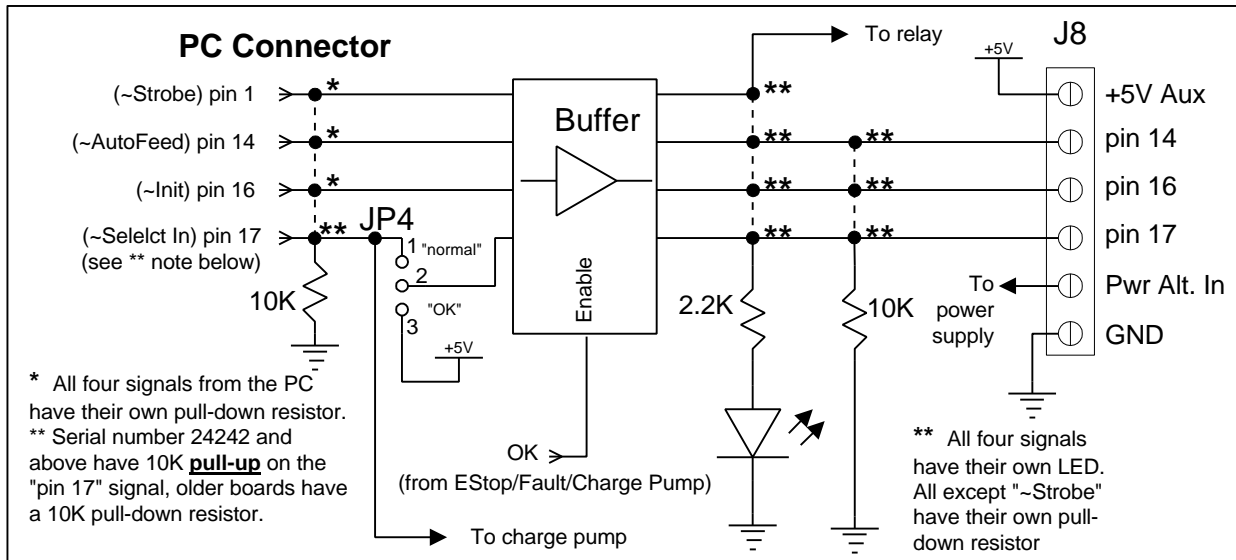

Figure 5 - Block diagram of Control Output Circuitry

The control inputs from the PC have pull-down resistors, except for the "pin 17" signal on newer boards as noted in Figure 5. This ensures a known output level on the screw terminal connector (logic low) should the parallel port cable become unplugged.

Connector J8 also provides an auxiliary +5V output, ground reference, and an alternate power supply input. The +5V output can be used to power external opto-couplers. The "PWR Alt In" terminal provides a screw-terminal alternative to J11 for connecting an AC or DC power source. It also can be a "daisy-chain power output" to a second PMDX-122 when power is supplied on J11. See section 7.2 for an example.

WARNING: When using the "Aux. Power In" on J8 pin 5, make sure that no power source is connected to J11 (the coax power input connector) or the USB connector.

NOTE - Due to logic inside the PC, some control outputs are inverted. This means that that writing a "1" to a bit in the control register may result in a logic "low" at the 25-pin "D" connector. Please refer to technical documentation on the PC parallel port or your control software for more information.

3.2.1 Control Outputs Enabled Jumper and LED

Jumper JP3 is labeled "Outputs Enabled" and is located just below and to the left of the serial number block. It selects the source for the "OK" signal, which is used to enable and disable the control outputs as well as a signal source the "OK" signal used by jumper JP2 to determine when the data bus outputs are enabled.

LED DS1 (labeled "Outputs enabled when lit") indicates when the control outputs are enabled. The LED is located just above the serial number block. The LED is "on" (and the control outputs are enabled) under the following circumstances:

- The *Fault* input is driven (or allowed to float) high (inactive), see section 3.4.1
- **And**, optionally, if the *E-Stop* input is driven low and jumper JP6 is configured in “normal” mode (see section 3.4.2). If jumper JP6 is configured to any other setting, the E-Stop input does not affect the control outputs.
- **And**, optionally, when the charge pump circuit is “OK” and jumper JP3 is configured in “CP-OK and not EStop/Fault” mode. If jumper JP3 is configured to “not EStop/Fault” then the charge pump is ignored and has no effect on the control outputs.

NOTE – The “Outputs enabled when lit” LED does not necessarily indicate when the data bus outputs are enabled. That depends on the setting of jumper JP2 (see section 3.1.3).

Setting	Label	Description
1 to 2	not EStop/fault	Control outputs are enabled (and the “OK” signal is asserted) when the <i>Fault</i> signal is NOT asserted, and optionally when the <i>E-Stop</i> signal is NOT asserted (depends on jumper JP6, see section 3.4.2). The charge pump circuit is ignored.
2 to 3	CP-OK & not EStop/fault	Control outputs are enabled (and the “OK” signal is asserted) when the charge pump circuit is OK and <i>Fault</i> signal is NOT asserted, and optionally when the <i>E-Stop</i> signal is NOT asserted (depends on jumper JP6, see section 3.4.2).

Table 5 – “Outputs Enabled” Jumper Settings (JP3)

3.2.2 General Purpose Outputs and LEDs

Three of the control signals are available as general-purpose outputs: pins 14, 16 and 17 (note that pin 17 is a special case with additional functionality, see section 3.2.3). The “Control Output” LEDs are located next to connector J8, just above each of the pin number labels (“pin 14”, “pin 16”, and “pin 17”). Each LED is “on” when the corresponding output signal is driven high.

Each control output has a 10K ohm pull-down resistor. This provides a logic low level whenever the control output buffer is disabled. Note that this is a fairly weak pull-down, and can be overridden externally with a stronger pull-up resistor if required.

3.2.3 Pin 17 Output

In addition to being available as a general-purpose output, the “pin 17” signal serves several additional (and optional) functions:

- Drives the charge pump circuit (see section 3.5). While pin 17 always drives the charge pump, the output of the charge pump may be ignored, depending on the setting of jumper JP3 (see section 3.2.1)
- Optionally, determines the direction of the data bus (depends on jumper JP5, see section 3.1.4)
- Optionally acts as a daisy-chain output of the fault/E-Stop/charge pump status, depending on the configuration of jumper JP4 (see the table below).

Jumper JP4 is labeled “pin 17 out” and selects the source for the “pin 17” signal on connector J8.

Setting	Label	Description
1 to 2	normal	Pin 17 from the PC parallel port drives the "pin 17" control output on J8 as well as the charge pump circuitry and possibly the data bus direction control (depending on the setting of jumper JP5, see section 3.1.4).
2 to 3	OK	Pin 17 from the PC parallel port drives only the charge pump circuitry (and possibly the data bus direction control, see section 3.1.4). The "pin 17" control output on J8 is driven "high" or floats low based on the state of the <i>E-Stop</i> and <i>Fault</i> inputs, the "charge pump" circuit and jumpers JP3 and JP6. See sections 3.4.2, 3.4.1 and 3.5 for more information. This setting allows the charge pump circuit to disable external drivers via opto-isolated relays and also allows daisy-chaining the fault/E-Stop/charge pump status to a second PMDX-122 (see section 7.2 for an example of daisy-chaining boards).

Table 6 – "Pin 17 Output Source" Jumper Settings (JP4)

3.2.4 Relay Control and LED (pin 1)

The "pin 1" control signal ("*~Strobe*") is dedicated to the on-board relay. The "pin 1" LED is located next to the relay contacts connector and indicates the state of the relay. The LED is "on" when the relay is energized (connecting the "N/O" terminal with the "RLY COM" terminal). The LED is "off" when the relay is de-energized (connecting the "N/C" terminal with the "RLY COM" terminal). A logic high on the pin 1 input from the PC (*~Strobe*) energizes the relay. Table 15 on page 20 shows the pin-out for the relay connector (J7).

NOTE – Due to logic inside the PC, the "*~Strobe*" control output (pin 1) is inverted. This means that writing a "1" to the bit in the control register results in a logic "low" at the 25-pin "D" connector. In order to energize the relay, a "0" must be written to the parallel port control register. Please refer to technical documentation on the PC parallel port or your control software for more information.

3.3 Status Inputs

Four of the status signals are available as general-purpose inputs: pins 11, 12, 13 and 15. The fifth status input on the PC parallel port (pin 10, *~Ack*) is connected to the *Fault* and *E-Stop* circuitry. See sections 3.4.2, *E-Stop Input* and 3.4.1, *Fault Input*, for more information on this signal. Figure 6 on page 15 shows a block diagram of the status input circuitry.

The "Status Input" LEDs are located next to connector J5, just above each of the pin number labels ("pin 11", "pin 12", "pin 13" and "pin 15"). Each LED is "on" when the corresponding input signal is driven low.

Each status input has a 10K ohm pull-up resistor and an RC low-pass filter (to remove high-frequency noise from the inputs). The pull-up resistor provides a logic high input level whenever the input terminal is not driven by an external source. The inputs may be driven by open-collector drivers or mechanical switches to ground, or to be left unconnected when not used. Note that this is a fairly weak pull-up, and can be overridden externally with a stronger pull-down resistor if required.

NOTE – Due to logic inside the PC, some status inputs are inverted. This means that a logic "high" output from the PMDX-122 to the PC's parallel port is read as a "0" in the status register. Please refer to technical documentation on the PC parallel port or your control software for more information.

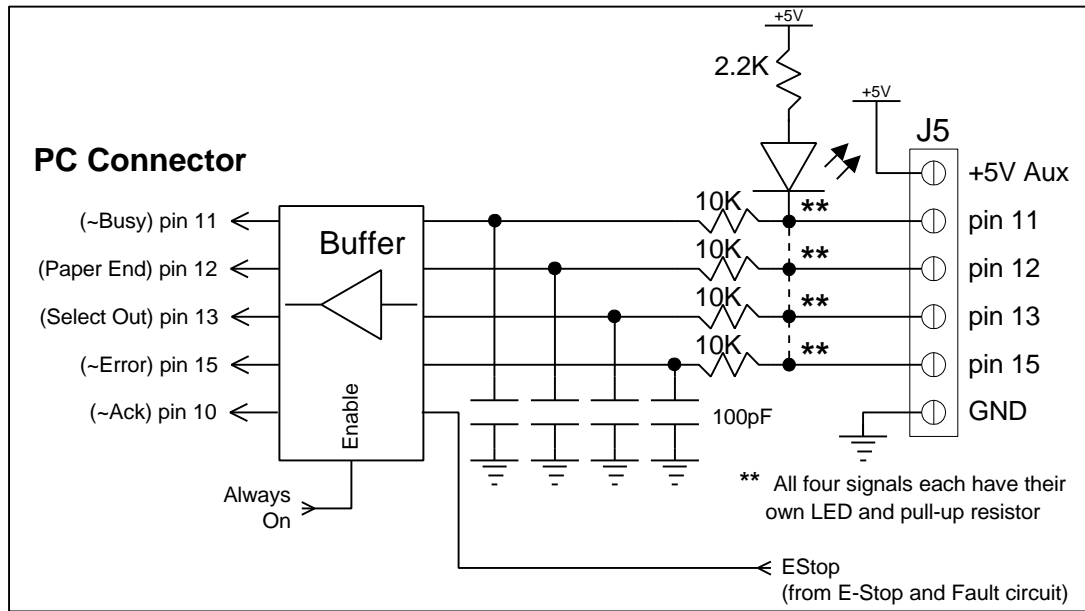

Figure 6 - Block diagram of Status Input Circuitry

3.4 Fault and E-Stop Inputs

The PMDX-122 provides both *E-Stop* (emergency stop) and *Fault* inputs. The operation of each input is described in the following sections. The function of the *E-Stop* and *Fault* inputs depends on the configuration of jumper JP6, as shown in Table 7 and the block diagrams below.

Setting	Label	Description
1 to 2 (Figure 7)	normal	The <i>E-Stop</i> input is an emergency stop signal. The <i>Fault</i> input has a 100K pull-up resistor so that its default state is "no fault". The <i>E-Stop</i> and <i>Fault</i> inputs combine to drive the "~Ack" signal (pin 10) into the PC parallel port and to optionally disable buffers on the PMDX-122.
2 to 3 (Figure 8)	signal only	The <i>E-Stop</i> input is a general-purpose input and directly drives the "~Ack" signal (pin 10) into the PC parallel port without affecting the data bus and control outputs on the PMDX-122 board. The <i>Fault</i> input has a 10K pull-down resistor and a 100K pull-up resistor so that its default state is "fault". This jumper setting can be used for daisy-chaining two PMDX-122 boards, see section 7.2.
Open (Figure 9)		The <i>E-Stop</i> input is a general-purpose input and directly drives the "~Ack" signal (pin 10) into the PC parallel port without affecting the data bus and control outputs on the PMDX-122 board. The <i>Fault</i> input has a 100K pull-up resistor so that its default state is "no fault" (i.e. the <i>Fault</i> input can be left unconnected if not used).

Table 7 - E-Stop Mode Jumper Settings (JP6)

NOTE - When jumper JP6 is set to the "normal" setting, the *Fault* input **must** be allowed to float high (or be driven high) in order for the output buffers to be enabled and for the "~Ack" status signal to the PC parallel port to go low.

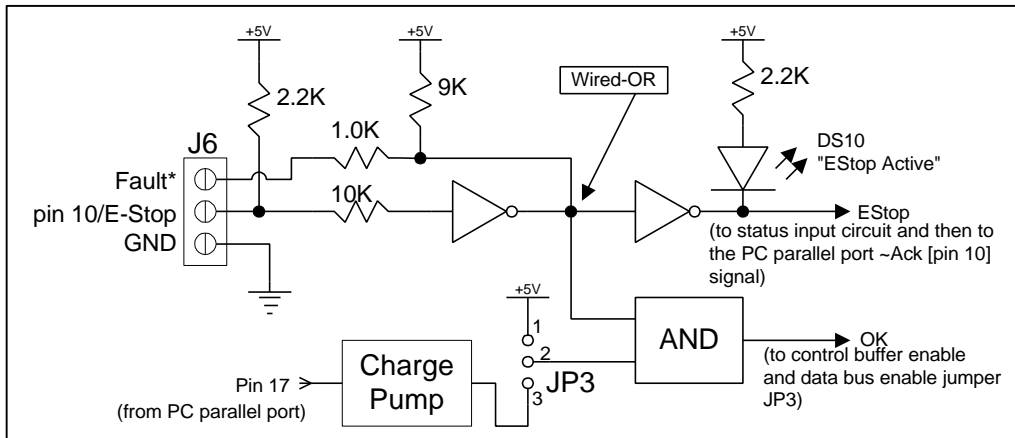

Figure 7 – Fault, E-Stop and Charge Pump when JP6 set to “pins 1-2”

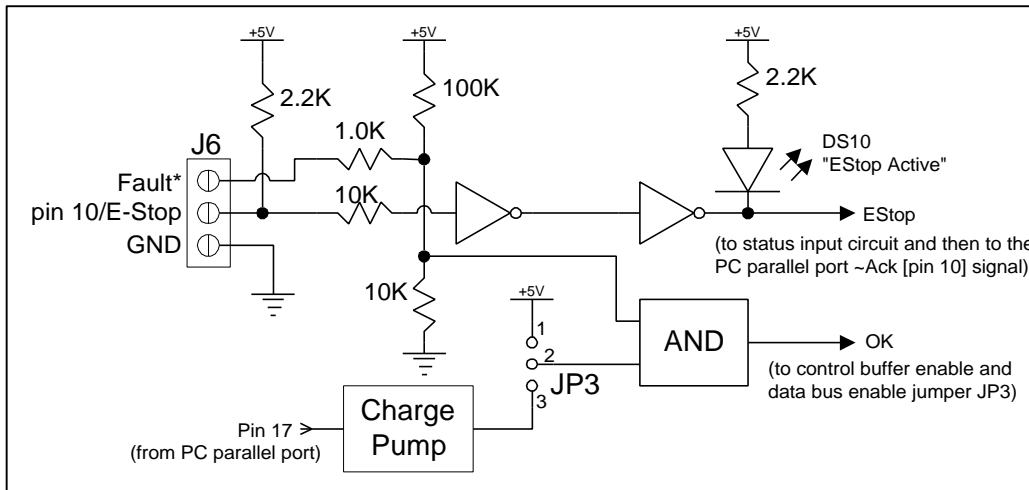

Figure 8 – Fault, E-Stop and Charge Pump when JP6 set to “pins 2-3”

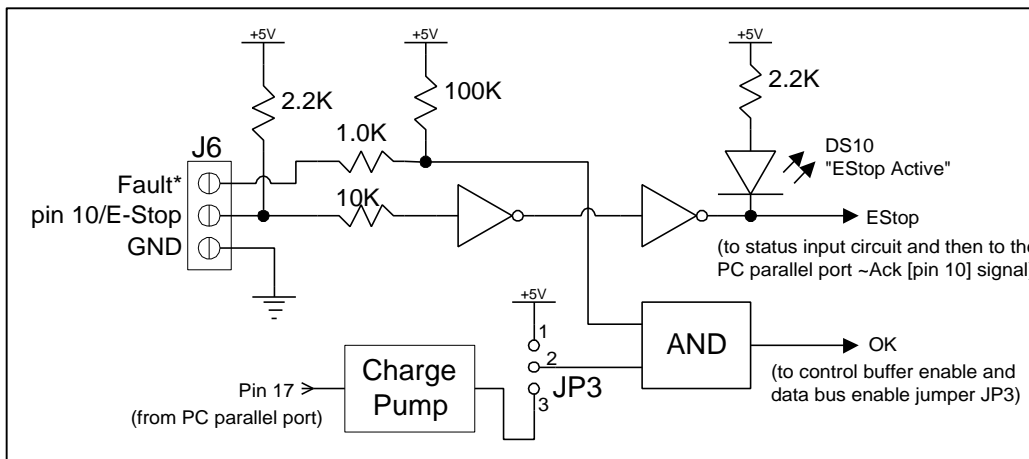

Figure 9 – Fault, E-Stop and Charge Pump when JP6 set to “open”

3.4.1 Fault Input

The *Fault* input provides an interface for external fault detection circuits, such as the fault signals from the PMDX-150 stepper motor drivers. This signal is "active low", meaning that a logic "low" indicates a fault condition, and a logic high means "all is OK". Figure 7, Figure 8 and Figure 9 on page 16 shows block diagrams of the *Fault* input circuitry for the various configurations of jumper JP6.

The *Fault* input can be connected to an external "wired-or" configuration of open-collector status signals or mechanical switches to ground (switch closed means "fault"). All of the external fault signals should be tied together and connected to the PMDX-122's *Fault* input. Depending on the configuration of jumper JP6, the *Fault* input has either a 100K ohm pull-up resistor or a 10K ohm pull-down resistor. See Table 7 on page 15.

When jumper JP6 is set to the "normal" setting, the *E-Stop* and *Fault* inputs are combined (logic "OR") to drive the "~Ack" status signal (pin 10) to the PC's parallel port. Refer to section 3.4.2.1, *E-Stop Input as "E-Stop" Signal*, for a list of actions that take place when the *Fault* input is driven low.

3.4.2 E-Stop Input

The *E-Stop* input has different functionality depending on the setting of jumper JP6, as described in the following sections. Figure 7, Figure 8 and Figure 9 on page 16 shows block diagrams of the *E-Stop* input circuitry for the various configurations of jumper JP6.

3.4.2.1 E-Stop Input as "E-Stop" Signal

When jumper JP6 set to the "normal" setting, the *E-Stop* input provides an interface for external "emergency stop" circuits (see Figure 7). This signal is "active high", meaning that a logic "high" tells the system to stop, and a logic low means "all is OK".

The *E-Stop* input is designed to be connected to an external "normally closed" switch (or group of switches all wired in series). The external switch(es) should be wired between the *E-Stop* pin and ground, such that the switch contacts open to signal an emergency stop condition. The PMDX-122 provides a 2.2K ohm pull-up resistor on the *E-Stop* input. This means that the external emergency stop circuit must be capable of sinking 2.7 mA of current when the switch contacts are "closed".

In this configuration, the *E-Stop* and *Fault* inputs are combined (logic "OR") to drive the "~Ack" status signal to the PC's parallel port and to enable or disable the data bus and control output buffers.

NOTE – With jumper JP6 set to the "normal" setting (pins 1-2), the *E-Stop* signal **must** be grounded (or driven low) in order for the data bus and control output buffers to be enabled, and for the "~Ack" status signal to the PC parallel port to go low.

When either (or both) the *E-Stop* (active high) or *Fault* (active low) inputs are asserted, the following actions take place:

- The ACK bit in the PC's status register reads as a "1"
- The LED labeled "E-Stop active" (reference designator DS10, near J6) is "on".
- The LED labeled "Outputs Enabled when lit" (reference designator DS1, near the center of the board) is "off"
- The control outputs are tri-stated with a weak (10K ohm) pull-down
- The relay is de-energized
- The data bus outputs **may** be tri-stated with a 2.2K ohm pull-up, depending on the setting of jumpers JP2 (see section 3.1.3) and JP5 (see section 3.1.4)

3.4.2.2 E-Stop Input as General-Purpose Input

When jumper JP6 set to "signal only" or "open", the *E-Stop* input acts as a general-purpose input that drives the "~Ack" status input on the PC parallel port without affecting the data bus and control outputs

on the PMDX-122 (see Figure 8 and Figure 9). The signal is not inverted on by the PMDX-122. A logic high on the *E-Stop* input is output as a logic high on the “~Ack” signal. When the *E-Stop* is used as a general-purpose input, the *Fault* input can be set to default to either “active” or “inactive”. See section 3.4.1 for more information.

3.4.2.3 “E-Stop” LED (DS10)

The “E-Stop” LED is located next to connector J6, and is labeled “E-Stop active”. The LED indicates the state of the “~Ack” signal to the PC (pin 10), which is driven by the *E-Stop* input and optionally by the *Fault* input. The LED is “on” when the *E-Stop* input is high (active). If jumper JP6 is configured as “normal”, then the LED will also be “on” when the *Fault* input is low (active). See sections 3.4.2, *E-Stop Input*, and 3.4.1, *Fault Input*, for more information on these signals.

3.5 Charge Pump (watchdog)

The charge pump circuit (also called a watchdog circuit) is designed to disable the PMDX-122 control outputs (and optionally the data bus outputs) when the software running on the PC stops working properly. It does this by monitoring pin 17 on the PC parallel port (the “~Select In” signal). When this signal is toggling between high and low, the charge pump is “OK”. When the “~Select In” signal stops toggling, the charge pump is “not OK”. Depending on the configuration of jumpers JP3 and JP2, the charge pump may cause the PMDX-122 to disable the output buffers when it is “not OK”. Jumper JP3 determines whether the output from the charge pump is used to enable and disable the control output buffers (see section 3.2.1). Jumper JP2 determines whether the step and direction outputs are ever disabled (see section 3.1.3). See also the block diagrams in section 3.4.

This charge pump circuit is designed to work with the Mach2/3 CNC software. However, any software that can toggle pin 17 on the PC parallel port can make use of this feature. If your software does not support this feature, configure the jumpers to disable the charge pump circuit.

NOTE – The state of the charge pump signal is **not** reflected in the *E-Stop* and *Fault* status that is output on the “~Ack” signal to the PC (pin 10 on the parallel port). This is to prevent “lock up” of the software. Mach2/3 CNC software requires that the Emergency Stop signal (~Ack) **not** be asserted before it will start generating the “charge pump” signal.

4.0 Summary of Connector Pinouts

The PMDX-122 contains several connectors, as listed in Table 8 below. Refer to the following tables for details on the pin-outs for each connector. For all connectors, pin “1” is the pin closest to the reference designator (i.e. J1 pin 1 is the pin closest to the “J1” text on the circuit board). In addition, all connectors have square pads on pin 1 (look on the bottom of the circuit board).

Connector	Description
J1, J2, J3, J4	Data Bus Signals (can be step and direction)
J5	Status Input Signals
J6	Fault and E-Stop inputs
J7	Relay contact outputs
J8	Control Outputs
J9	26-pin ribbon header (alternate connection to PC parallel port)
J10	Centronics 36-pin PC Parallel Port
J11	DC Power via a 2.1mm coax connector
J12	USB Connector (used for power only)

Table 8 – Summary of PMDX-122 Connectors

4.1 Data Bus Connectors (J1, J2, J3, and J4)

The data bus connectors are labeled to denote which pin on the PC's parallel port that is associated with each connector pin. "Pin 2" is data bus bit "D0" (the least-significant bit) and "Pin 9" is data bus bit "D7" (the most-significant bit).

Pin Number	Label	Description
1	Pin 2	Buffered signal from pin 2 of the PC parallel port's 25-pin "D" connector (parallel port signal name "D0")
2	Pin 3	Buffered signal from pin 3 of the PC parallel port's 25-pin "D" connector (parallel port signal name "D1")
3	COM	Common voltage reference, same for all four connectors (see section 3.1.2 for reference source)

Table 9 – Data Bus Connector Pin-Out (J1)

Pin Number	Label	Description
1	Pin 4	Buffered signal from pin 4 of the PC parallel port's 25-pin "D" connector (parallel port signal name "D2")
2	Pin 5	Buffered signal from pin 5 of the PC parallel port's 25-pin "D" connector (parallel port signal name "D3")
3	COM	Common voltage reference, same for all four connectors (see section 3.1.2 for reference source)

Table 10 – Data Bus Connector Pin-Out (J2)

Pin Number	Label	Description
1	Pin 6	Buffered signal from pin 6 of the PC parallel port's 25-pin "D" connector (parallel port signal name "D4")
2	Pin 7	Buffered signal from pin 7 of the PC parallel port's 25-pin "D" connector (parallel port signal name "D5")
3	COM	Common voltage reference, same for all four connectors (see section 3.1.2 for reference source)

Table 11 – Data Bus Connector Pin-Out (J3)

Pin Number	Label	Description
1	Pin 8	Buffered signal from pin 8 of the PC parallel port's 25-pin "D" connector (parallel port signal name "D6")
2	Pin 9	Buffered signal from pin 9 of the PC parallel port's 25-pin "D" connector (parallel port signal name "D7")
3	COM	Common voltage reference, same for all four connectors (see section 3.1.2 for reference source)

Table 12 – Data Bus Connector Pin-Out (J4)

4.2 Status Input Connector (J5)

Connector J5 provides access to four of the five status input signals. The fifth status input on the PC parallel port is connected to the *Fault* and *E-Stop* circuitry. See section 3.4.2, *E-Stop Input*, for more information on this signal.

Pin Number	Label	Description
1	+5V Aux Out	Auxiliary +5V output for external sensor power
2	Pin 11	Status input, buffered, to PC parallel port pin 11 (Busy)
3	Pin 12	Status input, buffered, to PC parallel port pin 12 (Paper End)
4	Pin 13	Status input, buffered, to PC parallel port pin 13 (Select Out)
5	Pin 15	Status input, buffered, to PC parallel port pin 15 (~Error)
6	GND	Ground connection

Table 13 – Status Input Connector Pin-Out (J5)

NOTE – Due to logic inside the PC, some status inputs are inverted. This means that a logic “high” output from the PMDX-122 to the PC’s parallel port is read as a “0” in the status register. Please refer to technical documentation on the PC parallel port or your control software for more information.

4.3 Fault and E-Stop Connector (J6)

J6 provides the *Fault* and *E-Stop* input signals to the PMDX-122. Refer to sections 3.4.2, *E-Stop Input* and 3.4.1, *Fault Input*, for more information on using these signals.

Pin Number	Label	Description
1	Fault*	Fault input (the “*” means active low, i.e. “ground” to signal a fault)
2	E-Stop	Emergency Stop input (active high, i.e. “open” to signal E-Stop). You must provide a ground via the E-Stop switch chain or a direct jumper in order to prevent an “E-Stop” condition, which may disable the data bus and control outputs on the PMDX-122 board.
3	GND	Ground connection

Table 14 – E-Stop and Fault Connector Pin-Out (J6)

4.4 Relay Contact Connector (J7)

The PMDX-122 provides a relay with both a “normally open” and “normally closed” contact. See section 3.2.4 for more information.

Pin Number	Label	Description
1	N/O	Normally Open relay contact (i.e. open when relay is not energized)
2	RLY COM	Relay common terminal
3	N/C	Normally Closed relay contact (i.e. closed when relay is not energized)

Table 15 – Relay Contact Output Connector Pin-Out (J7)

4.5 Control Output Connector (J8)

Pin Number	Label	Description
1	+5V Aux Out	Auxiliary +5V output
2	Pin 14	Control output from PC parallel port pin 14 (Auto Feed)
3	Pin 16	Control output from PC parallel port pin 16 (~Init)
4	Pin 17	Control output from PC parallel port pin 17 (~Select In) or logic level indicating whether the buffer is enabled or disabled, depending on the setting of jumper JP4 (see section 3.2.3)
5	PWR Alt In	Alternate power input terminal (also acts as a "daisy-chain power output" when the board is powered via the coax power connector J11).
6	GND	Ground connection

Table 16 – Control Output Connector Pin-Out (J8)

NOTE – Due to logic inside the PC, some control outputs are inverted. This means that that writing a "1" to a bit in the control register may result in a logic "low" at the 25-pin "D" connector. Please refer to technical documentation on the PC parallel port or your control software for more information.

4.6 PC Parallel Port Connectors (J10 & J9)

The PMDX-122 provides a Centronics-style connector (J10) for connections to a PC's parallel port. This allows the use of a standard PC printer cable. The board also provides a 26-pin ribbon cable header (J9). This header allows the use of a "ribbon cable to 25-pin "D" connector" adapter cable as an alternative to the standard PC printer cable and the Centronics connector.

NOTE – Some printer cables do not have good signal shielding. In addition, some cables omit some of the status or control signals (such as "Auto Feed" and "Select Out", 25-pin "D" connector pin numbers 14 and 13, respectively). We recommend using cables that are listed as IEEE-1284 compliant.

Pin Numbers			PC Signal Name	Direction (relative to the PC)	PMDX-122 Signal	Comment
PC (note 1)	J10 (note 2)	J9 (note 3)				
1	1	1	~Strobe	out	Relay control	Relay energized w/logic high at the PC pin (see section 4.4)
2	2	3	Data 0	out/in	Data bus output/input	Data bus signals are buffered and then connected to the PMDX-122's data bus connectors (see section 4.1)
3	3	5	Data 1	out/in		
4	4	7	Data 2	out/in		
5	5	9	Data 3	out/in		
6	6	11	Data 4	out/in		
7	7	13	Data 5	out/in		
8	8	15	Data 6	out/in		
9	9	17	Data 7	out/in		
10	10	19	~Ack	in	E-Stop & Fault	Driven high when <i>E-Stop</i> or (optionally) <i>Fault</i> input is active
11	11	21	Busy	in	Status Input	
12	12	23	Paper End	in	Status Input	
13	13	25	Select Out (note 4)	in	Status Input	
14	14	2	~Auto Feed	out	Control Output	
15	32	4	~Error	in	Status Input	
16	31	6	~Init	out	Control Output	
17	36	8	~Select In (note 4)	out	Control Output	Can act as charge pump or data bus direction control
18 – 25	19-30, 33	10-24 (even)	Ground		Ground	

Table 17- PC Parallel Port Connectors (J10 and J9)

NOTE 1 – The PC Pin number column lists the pin numbers as they would appear on the PC's 25-pin "D" connector when using a standard printer cable.

NOTE 2 – J10 is the Centronics 36-pin connector on the PMDX-122.

NOTE 3 – J9 is the 26-pin ribbon cable header on the PMDX-122.

NOTE 4 – The "*~Select In*" and "*Select Out*" signals are named relative to the printer's point of view. That is why the "*~Select In*" is an *output* from the PC, and "*Select Out*" is an *input*.

The following web sites provide information regarding the PC's parallel port, including pin-outs, signal names and useful data for software control of the parallel port:

- IBM PC Parallel Port FAQ and tutorial
<http://www.pmdx.com/Resources/parallel-port.html>
 and
<http://et.nmsu.edu/~etti/fall96/computer/printer/printer.html>
- General information and lots of links
<http://www.lvr.com/parport.htm>
- If the previous links do not work, go to <http://www.pmdx.com> (our main web page), click on the "handy CNC information" link and then look for the links to parallel port information pages

Note that these web links were accurate as of the printing date of this manual. While we expect that these non-PMDX sites will remain available at these addresses, it is possible that they will move or disappear.

4.7 Power Supply Connector (J11)

Connector J11 is used to provide +7 to +12 VDC *or* 6 to 9 VAC power to the PMDX-122. This connector is a standard 2.1mm diameter coaxial power connector that is compatible with many wall-mounted power packs.

WARNING: *When using J11, make sure that no power source is connected to J8 pin 5 (Aux. Power In). See section 3.2 for more information. Also, the USB connector should not be connected.*

Pin	Description
Center Pin	Positive voltage (or AC voltage)
Sleeve	Ground

Table 18 – Power Supply Connector Pin-Out (J11)

4.8 USB Connector (J12)

The USB connector can be used as an alternate power source for the PMDX-122. The PMDX-122 draws a maximum of 200mA from this connector. See section 9.0, *Electrical and Environmental Specifications*, for information regarding USB hub requirements. **When using the USB as a power source, do not connect any power source to J11 or to J8 pin 5.** The PMDX-122 has series diode protection on the USB power supply lines, so no damage to the USB host or the PMDX-122 should occur if another power source is connected along with the USB. It is better to avoid this situation in the first place, however.

NOTE – The PMDX-122 is *not* a USB device. It does not send or receive data or control information to the PC. There are no device drivers that need to be installed on the PC. The PMDX-122 uses the USB connector solely as an alternate power source.

WARNING: *Connect the PMDX-122 to self-powered USB hubs or directly to the PC's USB connectors. Do not attempt to power a PMDX-122 from a "bus-powered" USB hub as they may not provide sufficient power. Self-powered hubs use an external power supply, typically a "wall wart" style. Bus-powered hubs do not have an external power supply.*

5.0 Summary of Jumper Configurations

The PMDX-122 contains six 3-pin jumpers that determine various aspects of its functionality. Each jumper has silk screen labels that describe the function of the jumper and each possible setting. Each jumper can have a shorting block installed either between pins 1 and 2, or between pins 2 and 3. Some jumpers may also be configured with no shorting block installed.

Jumper	Description
JP1	Pin 2-9 (Data Bus) Common Jumper
JP2	Pin 2-9 (Data Bus) Enable Jumper
JP3	Outputs Enabled Selection Jumper
JP4	Pin 17 Output Source Jumper
JP5	Pin 2-9 (Data Bus) Direction Jumper
JP6	E-Stop Mode Jumper

Table 19 – Summary of PMDX-122 Jumpers

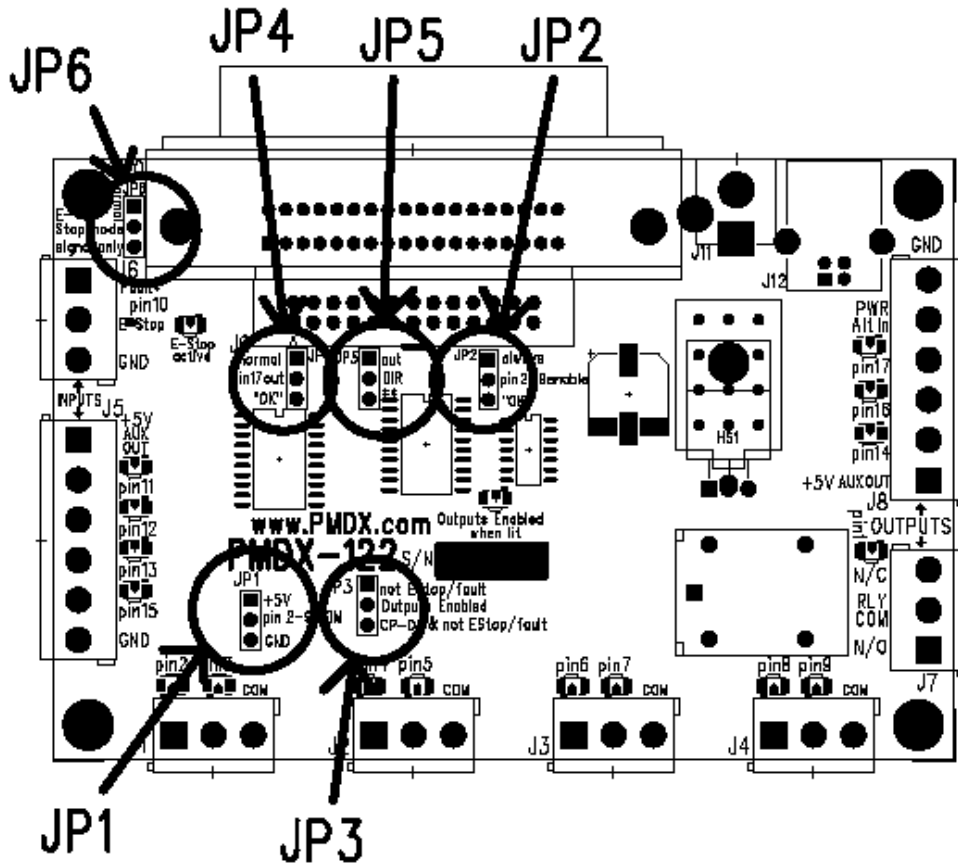

Figure 10 – Jumper Locations

Setting	Label	Description
1 to 2	+5V	Supplies an nominal +5V to the common terminals on J1, J2, J3 and J4. <i>See the note and warning in section 3.1.2.</i>
2 to 3	GND	Connects the PMDX-122's ground to the common terminals. See section 3.1.2 for more information.

Table 20 – Summary of “Pin 2-9 Common” Jumper Settings (JP1)

Setting	Label	Description
1 to 2	always	The data bus buffers are always enabled (i.e. ignore the <i>E-Stop</i> , <i>Fault</i> and charge pump circuits)
2 to 3	OK	Data bus buffers are enabled as long as the "Outputs Enabled" LED is "on". Note that this setting uses the "OK" signal from jumper JP3.

Table 21 – "Pin 2-9 Enable" Jumper Settings (JP2)

Setting	Label	Description ("OK" signal asserted when...)
1 to 2	not EStop/fault	Control outputs are enabled (and the "OK" signal is asserted) when the <i>Fault</i> signal is NOT asserted, and optionally when the <i>E-Stop</i> signal is NOT asserted (depends on jumper JP6, see section 3.4.2). The charge pump circuit is ignored. See section 3.2.1.
2 to 3	CP-OK & not EStop/fault	Control outputs are enabled (and the "OK" signal is asserted) when the charge pump circuit is OK and <i>Fault</i> signal is NOT asserted, and optionally when the <i>E-Stop</i> signal is NOT asserted (depends on jumper JP6, see section 3.4.2). See section 3.2.1.

Table 22 – "Outputs Enabled" Jumper Settings (JP3)

Setting	Label	Description
1 to 2	normal	Pin 17 from the PC parallel port drives the "pin 17" control output on J8 as well as the charge pump circuitry and possibly the data bus direction control (depending on the setting of jumper JP5, see section 3.1.4).
2 to 3	OK	Pin 17 from the PC parallel port drives only the charge pump circuitry. The "pin 17" control output on J8 is driven "high" or floats low based on the state of the <i>E-Stop</i> and <i>Fault</i> inputs, the "charge pump" circuit and jumpers JP3 and JP6. See sections 3.4.2, 3.4.1 and 3.5 for more information. This setting allows the charge pump circuit to disable external drivers via opto-isolated relays, or can be used to daisy-chain two PMDX-122 boards (see section 7.2).

Table 23 – "Pin 17 Output Source" Jumper Settings (JP4)

Setting	Label	Description
1 to 2	out	The data buffers are configured as "output" buffers (from the PC out through the PMDX-122).
2 to 3	**	The data buffer direction is dynamically controlled by the " <i>-Select In</i> " signal from the PC's parallel port (pin 17 on the 25-pin "D" connector). See section 3.1.4, <i>Data Bus Buffer Direction</i> , for more information. See the note and warning in section 3.1.4.
Open (jumper not installed)		The data buffers are configured as "input" buffers (through the PMDX-122 into the PC). See the note and warning in section 3.1.4.

Table 24 – Data Bus Direction Jumper Settings (JP5)

Setting	Label	Description
1 to 2	normal	The <i>E-Stop</i> input is an emergency stop signal. The <i>Fault</i> input has a 100K pull-up resistor so that its default state is "no fault". The <i>E-Stop</i> and <i>Fault</i> inputs combine to drive the "~Ack" signal into the PC parallel port and to optionally disable buffers on the PMDX-122.
2 to 3	signal only	The <i>E-Stop</i> input is a general-purpose input and directly drives the "~Ack" signal into the PC parallel port without affecting the data bus and control outputs on the PMDX-122 board. The <i>Fault</i> input has a 10K pull-down resistor and a 100K pull-up resistor so that its default state is "fault". This jumper setting is used for daisy-chaining two PMDX-122 boards, see 7.2.
Open		The <i>E-Stop</i> input is a general-purpose input and directly drives the "~Ack" signal into the PC parallel port without affecting the data bus and control outputs on the PMDX-122 board. The <i>Fault</i> input has a 100K pull-up resistor so that its default state is "no fault" (i.e. the <i>Fault</i> input can be left unconnected if not used).

Table 25 – E-Stop Mode Jumper Settings (JP6)

6.0 Summary of LEDs

The PMDX-122 provides LEDs to show the state of the data, status and control signals. These LEDs are described in the following table:

Reference Designator	LED Name	Function
N/A	"pin 2" to "pin 9" (data bus LEDs)	8 each LEDs, one for each data bus signal. Each LED is "on" when the corresponding data signal is low. See section 3.1.1.
DS1	Outputs Enabled	This LED is "on" when the control output buffers are enabled. See section 3.2.1.
N/A	Status Input	4 each LEDs, one for each status input signals on connector J5. Each LED is "on" when the corresponding status terminal is grounded or driven to a logic low. See section 3.3.
N/A	"pin 1" (relay status LED)	This LED is "on" when the relay is energized. See section 3.2.4.
N/A	"pin 14", "pin 16" and "pin 17" (control output LEDs)	3 each LEDs, one for each control signal on connector J8. Each LED in "on" when the corresponding control output terminal is driven high. See section 3.2.
DS10	E-Stop active	This LED is "on" when the E-Stop input is driven or floating high. Note that this LED may also indicate the state of the <i>Fault</i> input, depending on the setting of jumper JP6. See section 3.4.2.

Table 26 – Summary of LEDs and functions

7.0 Advanced Configurations

7.1 Configuring a PMDX-122 to Emulate a PMDX-121

To make the PMDX-122 function the same as the older PMDX-121, set the following jumpers:

JP1	Same as PMDX-121	JP4	Same as PMDX-121
JP2	Same as PMDX-121	JP5	Jumper pins 1 and 2 (data bus is "output", see section 3.1.4)
JP3	Same as PMDX-121	JP6	Jumper pins 1 and 2 ("normal" mode, see section 3.4)

NOTE – This configuration is not a perfect emulation of the PMDX-121. Refer to section 1.5, *Differences Between the PMDX-122 and the PMDX-121*, specifically for the difference in data bus output pull-up/pull-down resistors.

7.2 Example Daisy-Chain PMDX-122 with Encoder Inputs

Figure 11 on page 28 shows two PMDX-122 boards daisy-chained to each other, using two parallel ports on the PC. Note that "daisy chaining" refers only to the charge pump, E-Stop and Fault functions. This configuration allows both boards to respond in the same manner to any fault condition. You must connect the second board to a second parallel port on your PC in order to use the data bus, control outputs and status inputs.

The first board acts as the "master" and implements the E-Stop, Fault and "charge pump" functions and connects to the stepper driver modules. The second board is the "slave", and configures the data bus for "input to the PC" for use with optical encoder inputs (for example). The *Fault* input on the second board is connected to the "Pin 17" output on the first board so that both boards disable their outputs on any fault or E-Stop condition or charge pump failure.

NOTE – When powering the second PMDX-122 from the first (as shown in Figure 11), board #1 must be powered via J11 or the "PWR Alt. In" terminal on J8. Power from a USB hub cannot be daisy-chained to the second board.

WARNING: *Configuring the data bus on board #2 as "always input" will cause drive conflict with PC's parallel port until PC runs the application that makes the parallel port an input. This may cause erratic behavior on the daisy-chained PMDX-122 until the PC's parallel port is changed to an input port.*

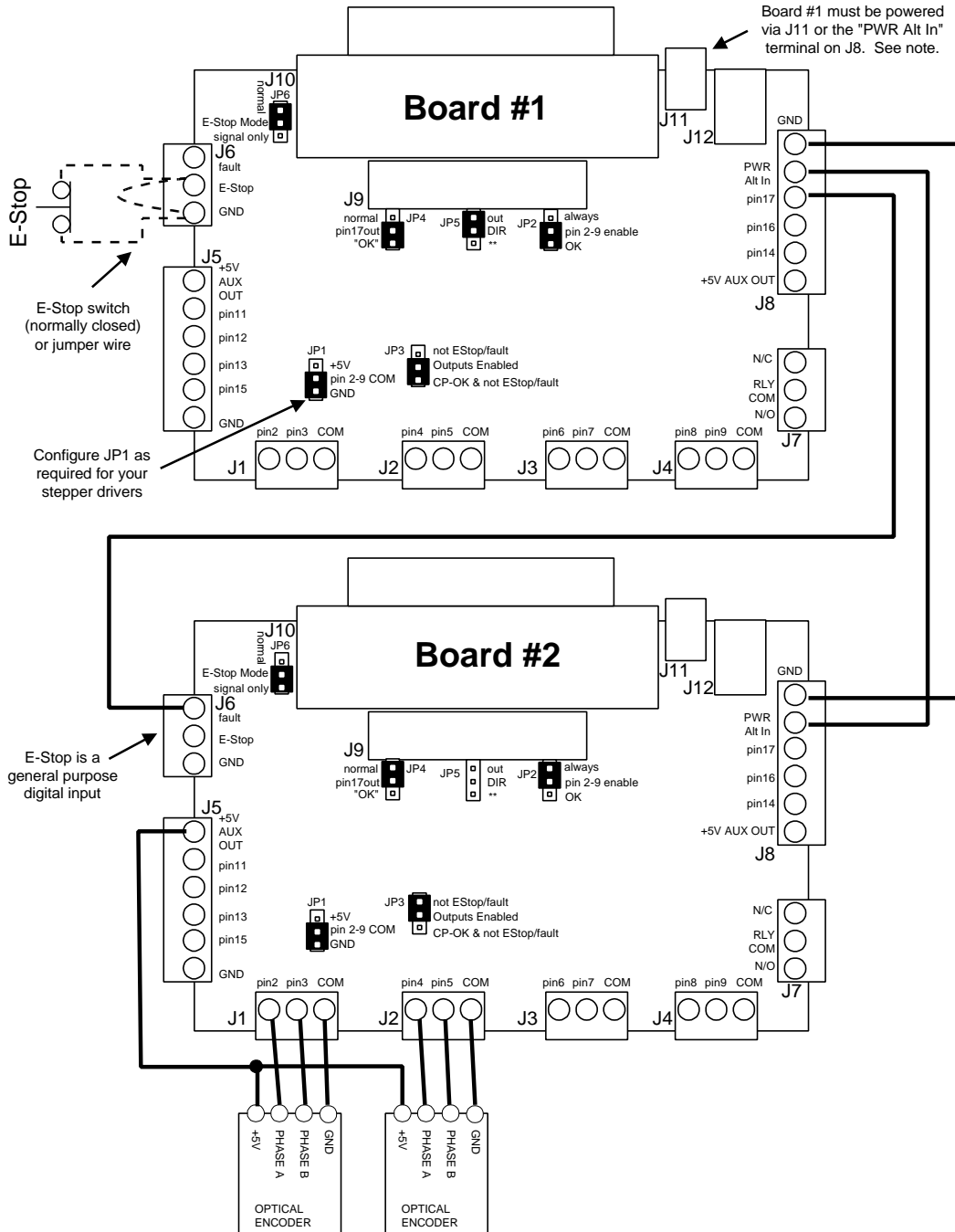

Figure 11 - Configuration with Daisy-Chain PMDX-122 Boards and Encoder Inputs

8.0 Mechanical Specifications

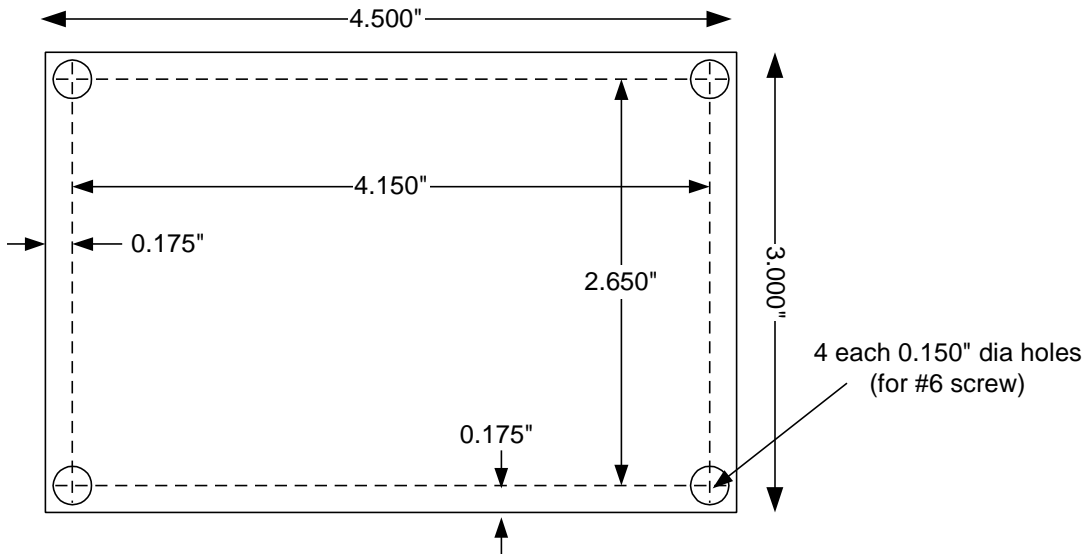

Figure 12 - PMDX-122 Dimensions and Mounting Holes

WARNING: *The PMDX-122 should be protected from liquids, dirt, or chips (especially metal chips which can cause shorts) coming in contact with the board.*

9.0 Electrical and Environmental Specifications

Main Power: +7 to +12 VDC **or** 9 VAC input, 200 mA maximum (input via J11)

USB Power: +5V DC, 200 mA maximum (optional power source as alternate to the main power)

Note 1: According to the USB specification, a USB hub supplies only 100mA to an uninitialized device (which is how the PMDX-122 appears to the hub). However, most self-powered USB hubs, including those built into PCs, provide 200mA, which is the maximum current allowed per USB port. Note that self-powered USB hubs use some sort of external power supply, such as a "wall wart" supply, whereas bus-powered hubs do not. Only connect the PMDX-122 to self-powered USB hubs or directly to a PC's USB port. **Do not attempt to power the PMDX-122 from a bus-powered USB hub. Do not daisy-chain PMDX-122 boards when powered from a USB port.**

Status Inputs: Min. input "high": 2.0V (referenced to the "Gnd" terminal)
 Max. input "low": 0.8V (referenced to the "Gnd" terminal)

Data Outputs: Min. output "high": 3.8V sourcing up to 16mA per output (see note 2)
 Max. output "low": 0.8V sinking up to 16mA per output (see note 2)

Note 2: The current spec is valid only when the outputs are enabled. Voltages are referenced to the "COM" term when JP1 is set to "GND" and JP5 is set for "output". The output "high" voltage may be lower if the outputs are disabled and the PMDX-122's pull-up resistor is providing the output voltage. When the outputs are disabled, the actual output voltage depends on the load that is connected to the PMDX-122 data outputs.

Data Inputs: Min. input "high": 2.0V (see note 3)
 Max. input "low": 0.8V (see note 3, external source must sink at least 3mA per input)

Note 3: Referenced to the "COM" term when JP1 is set to "GND" and JP5 is set for "input".

Control Outputs: Min. output "high": 3.7V (referenced to the "Gnd" terminal, sourcing up to 16 mA per output)
 Max. output "low": 0.4V (referenced to the "Gnd" terminal, sinking up to 16 mA per output)

Relay Contact Ratings: 10 amperes at 24 VDC,
 10 amperes at 120 VAC,
 10 amperes at 240 VAC

Charge Pump: Min. Frequency: 100 Hz minimum square wave on pin 17.

Environmental: Temperature: 0° to +55° C
 Relative Humidity: 20% to 80% relative humidity, non-condensing

Appendix A – Warranty

Statement

Practical Micro Design, Inc. (PMD) warrants that this hardware product is in good working condition, according to its specifications at the time of shipment, for a period of 90 days from the date it was shipped from PMD. Should the product, in PMD's opinion, malfunction within the warranty period, PMD will repair or replace the product without charge. Any replaced parts become the property of PMD. This warranty does not apply to the software component of a product or to a product which has been damaged due to accident, misuse, abuse, improper installation, usage not in accordance with product specifications and instructions, natural or personal disaster or unauthorized alterations, repairs or modifications.

Limitations

All warranties for this product, expressed or implied, are limited to 90 days from the date of purchase and no warranties, expressed or implied, will apply after that period.

All warranties for this product, expressed or implied, shall extend only to the original purchaser.

The liability of Practical Micro Design, Inc. in respect of any defective product will be limited to the repair or replacement of such product. Practical Micro Design, Inc. may use new or equivalent to new replacement parts.

Practical Micro Design, Inc. makes no other representations or warranties as to fitness for purpose, merchantability or otherwise in respect of the product. No other representations, warranties or conditions, shall be implied by statute or otherwise.

In no event shall Practical Micro Design, Inc. be responsible or liable for any damages arising

- (a) from the use of the product;
- (b) from the loss of use of the product;
- (c) from the loss of revenue or profit resulting from the use of the product; or
- (d) as a result of any event, circumstance, action or abuse beyond the control of Practical Micro Design, Inc.

whether such damages be direct, indirect, consequential, special or otherwise and whether such damages are incurred by the person to whom this warranty extends or a third party.