

# MODEL 8000-8610B

## FREQUENCY COUNTER

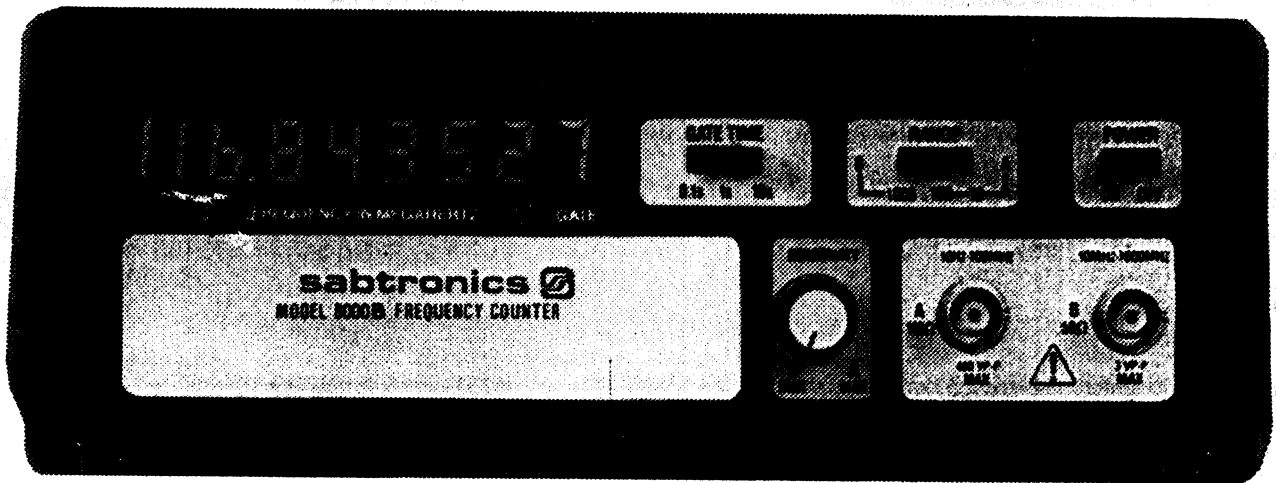

**sabtronics** 



MODELS 8000B & 8610B 9-DIGIT FREQUENCY COUNTERS  
SPECIFICATIONS

FREQUENCY RANGE: 10Hz - 600 MHz in 3 ranges (Model 8610B)  
10Hz - 1 GHz in 3 ranges (Model 8000B)

INPUT IMPEDANCE: Input A: 1M $\Omega$ /100pF  
Input B: 50 $\Omega$  nominal

SENSITIVITY: 10mV rms, 10Hz - 10 Mhz  
25mV rms, 10 -400 MHz  
45mV rms, 400 MHz - 1 GHz

INPUT PROTECTION: 400V P-P at 10Hz declining with frequency  
to 3V P-P at 1 GHz

GATE TIMES: 0.1 sec., 1 sec., 10 sec switch selectable

DISPLAY: 9-digit 0.4" (9mm) LED with automatic decimal  
point. Leading zero suppression. Discrete LED  
gate status indicator.

MAX. RESOLUTION: 0.1 Hz on 10 MHz range with 10 second gate time  
1 Hz on 100 MHz range with 10 second gate time  
10 Hz on 600 MHz/1 GHz range with 10 second gate time

TIME BASE: FREQUENCY: 10 MHz  
TEMPERATURE STABILITY:  $\pm 1$  ppm from 0 $^{\circ}$ -40 $^{\circ}$ C  
SETABILITY:  $\pm 2$  ppm  
AGEING RATE: <5 ppm/year

MEASUREMENT ACCURACY: 1 Hz + 1 digit + Time Base error

POWER REQUIREMENT: 4.5-6.0V DC @ 300 mA (4 "c" cells) or optional  
ac adapter/charger. (9 -12vDC)

DIMENSIONS: 8"W x 7.3"D x 3"H (203 x 185 x 76 mm)

WEIGHT 1.3 lbs (590 g) without batteries

OPTIONAL ACCESSORIES: #NB-120 NiCd Batteries  
#AC-120 AC Adapter/Charger  
#LFP-10 Audio pass probe  
#RFA-10 Telescopic RF pick-up antenna

NOTE: Specifications and prices subject to change without prior notice.

- 2 -  
OPERATING CONTROLS AND FEATURES

REF. #	NAME/DESCRIPTION	FUNCTION
1	DISPLAY	A 9 digit display of measured input in MHz including decimal point, except in 10 MHz range with 10 second gate time, where indication is in Hz.
2.	GATE INDICATOR	Flashing LED indicates time period.
3.	GATE TIME SWITCH	Selects the sample rate; 0.1sec, 1 sec, or 10 sec.
4.	RANGE SWITCH	Selects maximum frequency range to be measured. Note that in 1000 MHz range the input must be through the 50Ω jack (ref.6) while on 10 and 100 MHz ranges the input must be on the 1 MΩ jack (ref.7)
5	ON/OFF SWITCH	Applies power to the frequency counter when placed in the ON position.
6	INPUT JACK - 50Ω	Signal to be measured is applied through the BNC jack with an input impedance of 50Ω. This input is used only with the range switch (ref.4) on the 1000 MHz.
7	INPUT JACK - 1MΩ	Signal to be measured is applied through the BNC jack with an input impedance of 1 MΩ. This input is to be used only with the range switch (ref.4) on the 10 or 100 MHz ranges.
8.	SENSITIVITY CONTROL	With the sensitivity completely clockwise maximum sensitivity is achieved on the 1 MΩ input, while with the sensitivity completely counter-clockwise maximum sensitivity is achieved on the 50Ω input. In each case, moving the sensitivity knob away from the maximum sensitivity position reduces the sensitivity.

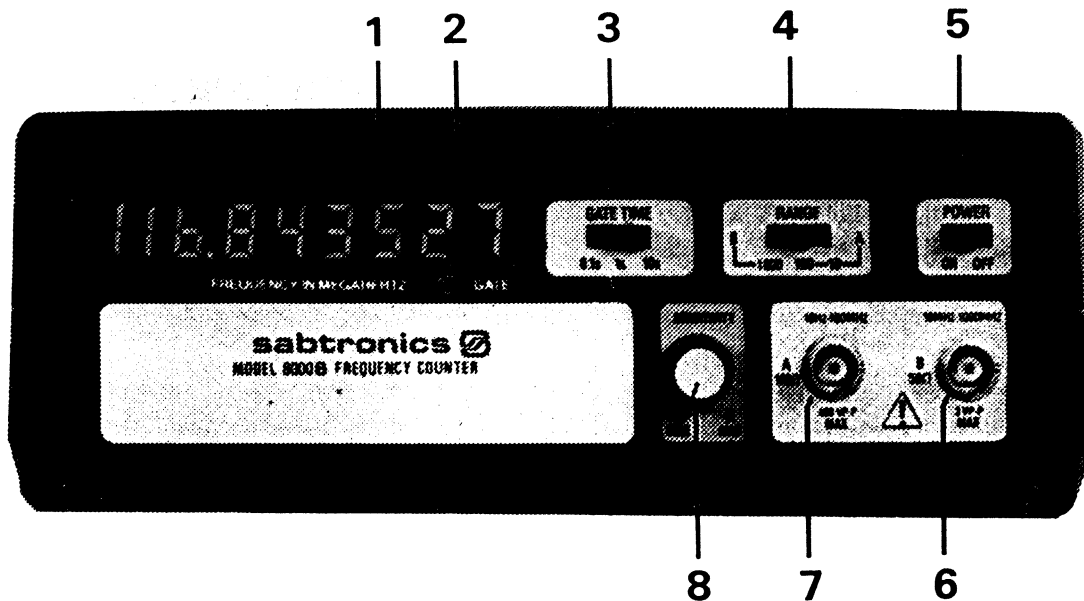

## THEORY OF OPERATION

In order to get the most benefit from your Sabtronics frequency counter, an understanding of the circuit operation is often useful. We have attempted, whenever possible, to utilize the latest developments in large scale integration to provide the greatest possible performance for the money and, at the same time, to reduce the circuit complexity and therefore increase reliability. There are only three IC's in the main board and two IC's in prescaler, (3 for the model 8000B).

Ignoring the prescaler for the moment, let us assume the input signal arrives at the 10Hz to 100MHz input labeled P1. This signal is first amplified by the Q1-Q2 pair. The three amplifier stages identified as Z1 in the schematic are ECL logic stages biased in its linear region, each stage having a gain before feedback of about 5. A positive feedback at the output of the third amplifier when reflected through the gain of the preceding three amplifier stages (including the Q1-Q2 pair) results in about a 5mv hysteresis in the input triggering levels to aid in noise rejection. Q3 and Q4 translate the ECL levels to TTL levels. Z2 divides the signal by a factor of 10 and presents a maximum of a 10 MHz signal to the counter Z3.

If the range switch is in the 1GHz position (600 MHz for the 8610B) the input is AC coupled to a preamplifier on the prescaler IC then to a divide by 20 combination [On the 8000 the input signal is first reduced by a high speed divide by two circuit followed by a divide by 10 circuit capable of handling 500 MHz, while in the 8610B a single IC accomplishes the entire 20-fold frequency reduction, but is able to handle signals only up to 600 MHz.] The maximum frequency coming from the prescaler board will thus be 50 MHz which is divided by five in Z2 and presented to the counter chip.

The integrated circuit chip Z3 performs three functions in this counter:

- 1) An internal oscillator utilizes the crystal connected between pins 25 and 26 to create a 10MHz signal which is internally counted to give periods of .1 second, 1 second, or 10 seconds depending on whether pin 14 is connected to pins 5, 4, or 6 respectively.
- 2) The signal appearing on pin 28 is counted and the number of cycles within the period determined in 1) above is stored internally.
- 3) Each digit in the sum established in 2) above is successively examined and the digit drive pin (3,5,4,6,8,9, 10, or 11) appropriate to that digit is grounded and the value of that digit is converted to the seven segment display format and outputted on the segment drive pins (20,17,16,19,21,15 and 22).

A count exceeding the eight digits stored is detected and this condition is identified by a decimal point output while pin 11 is grounded. This condition is used to drive the digit "1" in the ninth position from the right through Q5, Q6 and Q7.

Z4 regulates the input 9 volt signal from the optional line voltage converter and charges the battery pack. When the power switch is in the "on" position, approximately 4.8 volt is applied through CR6 and R21 to charge B1, while in the "off" power switch position about 5.5 volts is applied through CR6 and R21 to charge B1.

## OPERATION SUGGESTIONS

Sabtronics' model 8000B and 8610B provide two of the more desirable traits of a good counter - fast response time and low input sensitivity. While this combination of features will provide you with a powerful tool for many of your investigations, you will also find that it is less forgiving when improperly used. When used to measure pure sine waves of proper amplitude with no DC component, an unambiguous reading will be returned. For the signals existing in the real world an understanding of the reaction of the counter to various input waveforms is necessary to insure that the indicated meter reading is truly what you intend to measure.

In order to give an unambiguous logic state for any input voltage, positive feedback is introduced into the amplifier stage in the 100 MHz input. This leads to a hysteresis of several millivolts in the input triggering point, or the condition where the triggering point for a positive-going waveform is higher than that for a negative-going waveform. Noise immunity is improved with such a system since minor fluctuations in the input waveform will not trigger a count unless the amplitude of these fluctuations exceed the hysteresis band as shown in figure 1. Where noise is suspected and the frequency limitation is not expected to be a factor, the 10 Hz-100 MHz input should be used, as the 1 GHz input contains no hysteresis.

Some of the sources for noise on the input line and ways of reducing their effect are listed below.

<u>SOURCE</u>	<u>REMEDIAL STEPS</u>
1. R.F. pickup (note that due to the frequency limitations of most oscilloscopes, there may be high frequency components present that will not show up in normal investigations but which will trigger the counter).	a. Shield all input lines. b. Where low frequencies are measured a low pass filter as illustrated in figure 2 can be inserted in the line to attenuate high frequency components which may cause false triggering. Sabtronics supplies such a unit as its LFP-10 with a built-in filter bypass switch for operation in either the normal or high frequency attenuation mode. c. Avoid ground loops. d. If sufficient signal is available, attenuation of the input signal through a series resistor will often attenuate the noise components so that they will not

SOURCE (cont'd)

REMEDIAL STEPS (cont'd)

2. Ringing of logic level inputs
3. Harmonic distortion
- be counted, as well as providing some high frequency rolloff (due to the input capacitance of the counter) and damping of ringing.
- a. Terminating both ends of the signal with a resistor equal to the characteristic impedance of the cable can prevent multiple reflections which appear as "ringing" of the signal transitions as shown in fig. 3.
  - b. A series resistor or low pass filter with a time constant no more than the expected frequency will overdamp the circuit and prevent the counter from seeing the full "ringing" voltage.
  - c. Phase-sensitive delay on transmission lines often cause distortion of the signal which can lead to false triggering. For this reason the input signal lines should be kept as short as possible.
- a. If the harmonic content of the incoming signal is of sufficient amplitude the counter may count some of the harmonics. If this is the case, either the source must be adjusted, or the harmonics must be filtered out

If amplitude-modulated signals are measured it is possible at times that the signal envelope could be below the triggering level causing an incorrect count.

When used to pick up RF sources a maximum of three turns of #22 wire, as shown in fig. 4, should provide a sufficient probe. A low-voltage incandescent lamp such as a #48 connected across the line at the counter's input will provide a visual indication of the relative power levels, a line termination and a limit on the maximum power input to the counter.

An adjustable antenna, RFA 10, for direct connection to the counter's BNC terminals is also available from Sabtronics. When using this antenna, the antenna length should be adjusted to 1/4 wavelength if possible and the antenna rotated for maximum input.

Both the 1 GHz and the 100 MHz inputs are AC coupled to block DC offsets which would possibly shift the signal out of the counting range. If the DC level varies during a measurement, this could shift the signal level during the time the blocking capacitor is charging to its new level, possibly biasing the signal out of the counting range.

FIGURE 1

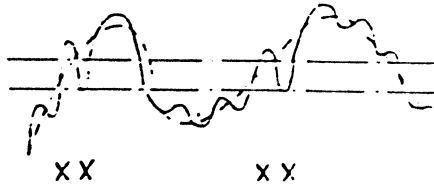

----- ideal signal  
———— actual signal  
- - - - trigger levels (top for positive-going signals, bottom for negative-going signals)

FIGURE 2

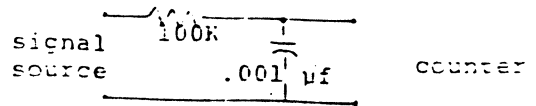

FIGURE 3

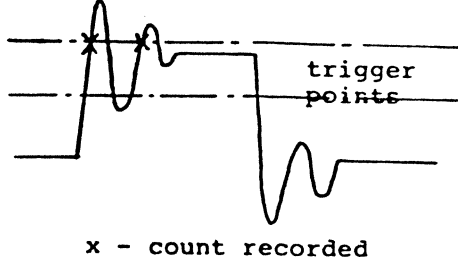
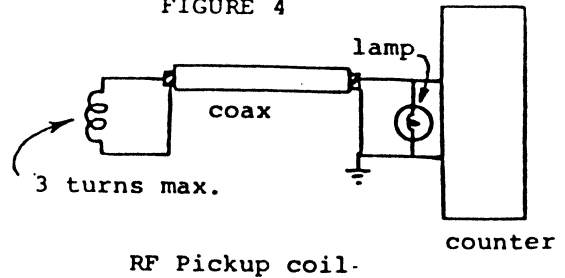

FIGURE 4





## CALIBRATIONS

There are two calibration points on your counter. With the sensitivity knob turned all the way to the right, TP1, which can be found on the right hand middle side of the circuit board, must be adjusted by turning R3 until TP-1 is at 3 volts with respect to ground. This establishes a bias point for the ECL amplifiers.

The frequency accuracy of the entire oscillator is essentially determined by the accuracy of the crystal oscillator operating off crystal XC-1. Adjustment of this oscillator frequency can be made by means of trimmer capacitor C11. The best way to calibrate this point is to feed a signal of known frequency, (preferably between 3 and 50 MHz) and sufficient amplitude to the counter and to adjust C11 so that the known frequency is indicated on the LED readout. For maximum resolution, the 1 sec gate position and the 100 MHz input should be used. A nonmetallic screwdriver or TV alignment tool should be used to avoid pickup by C11.

One method of calibrating the frequency is to use a short wave radio tuned to WWV, the time standard broadcast of the National Bureau of Standards, which can be received at 10 MHz. If the counter is operated in the vicinity of the radio, emissions from the 10 MHz internal oscillator will combine with the WWV signal and a "beat" frequency, (a signal with a frequency equal to the difference between the two 10 MHz signals), can be heard. C11 should be adjusted to a zero "beat frequency".

Note that there is a hole through the plastic front panel in front of C11 so that if you want to make the adjustment of C11 without removing the front panel each time, a razor blade can be used to open that hole through the front panel label.

\* Outside the U.S.A. many countries also provide standard frequency and time station at 10 MHz, such as ATA (India), JJY (Japan), LOL (Argentina), MSF (United Kingdom), and RWM (USSR).

## TROUBLESHOOTING

If a problem should develop in your Sabtronics counter several tests can localize and often eliminate the problem. A good visual inspection of the circuit board, looking for solder shorts and components which may be touching each other, or the coaxial cable shield, is recommended. The following tests will require a voltmeter, an oscilloscope, and some knowledge of electronics.

### SYMPTOM

### ACTION REQUIRED

No output or gate LED

Check the power supply at point A shown in figure 6 with a voltmeter. The voltage should read at least 5 volts. If the voltage is low, check the batteries, the wiring to the batteries, and the external AC adaptor if used, and a check for short circuits on the power base. If the power is good, and there is no gate signal on the LED, the solder connections to the crystal (XL-1) should be examined and, if correct, the problem is probably in Z3.

No count, always reads zeros even with an input on the 100 MHz connector and switches set at 100MHz

Drive the 100 MHz input from a signal generator putting out at least 50 M.V. at a frequency well below the 100 MHz. The following procedure tracks this signal as it proceeds from the input to the counter chip to determine where its progress is stopped. You should start at point B and make sure the signal is detected at each point before continuing to the next step.

point B - this point is the signal input to the board. Failure to detect the signal here means there is a break or short in the input cable.

point C - this point should have a DC level of 2-4 volts. If this DC level or the input signal is not present Q2 or Q1 is probably defective.

point D failure to see the input signal at this point suggests a problem with Z1.

point E (TTL level) lack of signal indicator Z2 is faulty or signal path is broken or shorted. Presence of signal here with no count indicated indicates faulty Z3.

No count, always reads zero with an input on 50 $\Omega$  input

Check with reduced frequency input on system set up for measurement on 100 MHz input. If no count is still found, start preceding error check at point E. If count is found on 100 MHz input check on prescaler card at coax cable input from the front panel to insure it is not open or shorted, the coax output cable, and at the power and ground leads to the prescaler board for proper voltage.

Only one digit lit

The oscillator in Z3 is probably not functioning. Check the solder connections around the crystal (XL-1).

Will not count to maximum specified frequency.

This is often due to the power supply (measured at point A in fig. 6) being too low. It should run at about 5.75 volts  $\pm$  .2 volts. If it is too low the batteries are probably run down. If the optional AC adaptor is used, make sure that CR4 and CR5 are not shorted and that the voltages on the left terminals of Z4 is about 9 volts or greater, showing that the external adaptor is indeed supplying its voltage. If a sufficient voltage is measured and point A is less than +5.5 volts (but not close to zero which would suggest a short on the voltage bass) then Z4 should be replaced.

If there is a question on the LED readouts, connecting points G and H momentarily with a jumper wire will light up all the segments except the most significant digit which will appear as a one.

### 8000B - 1 GHz PRESCALER

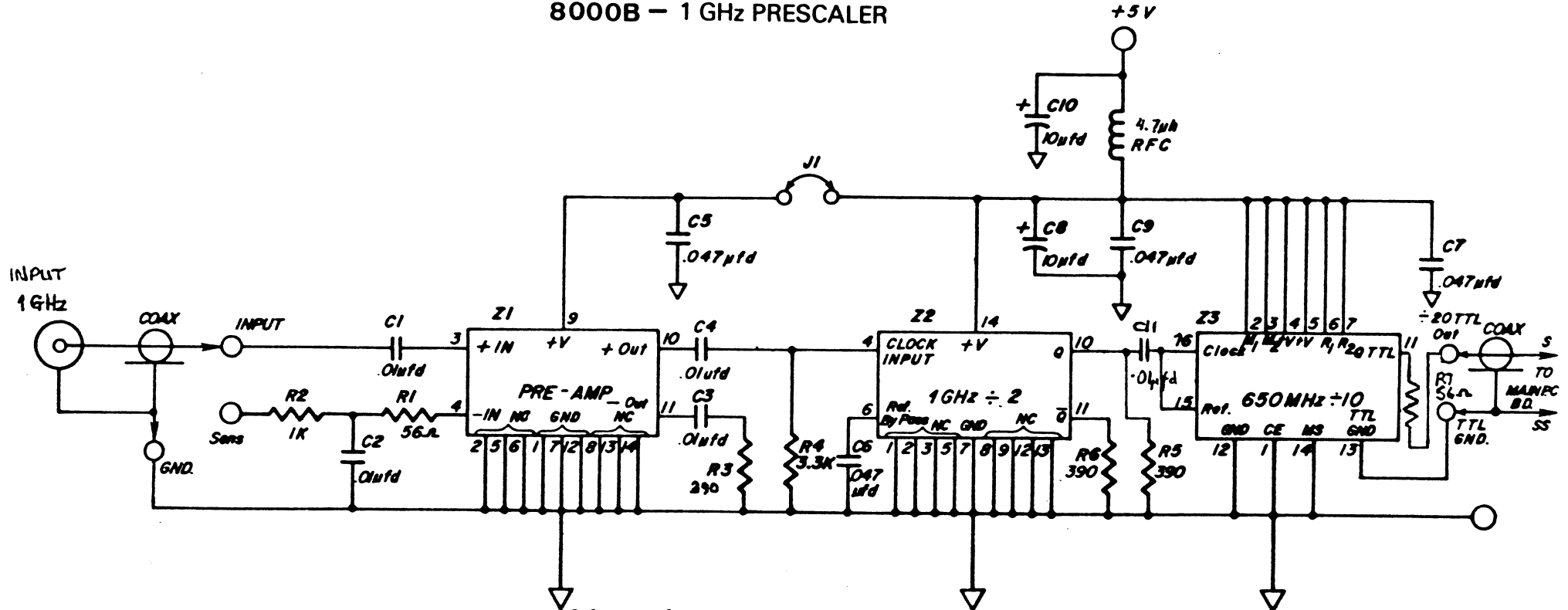

### 8610B-600MHz PRESCALER

Components omitted :  
 R4, R5, R6, C6, C11, Z2  
 Components added :  
 56R between pins 4, 10  
 of Z2.  
 Link instead of C11.

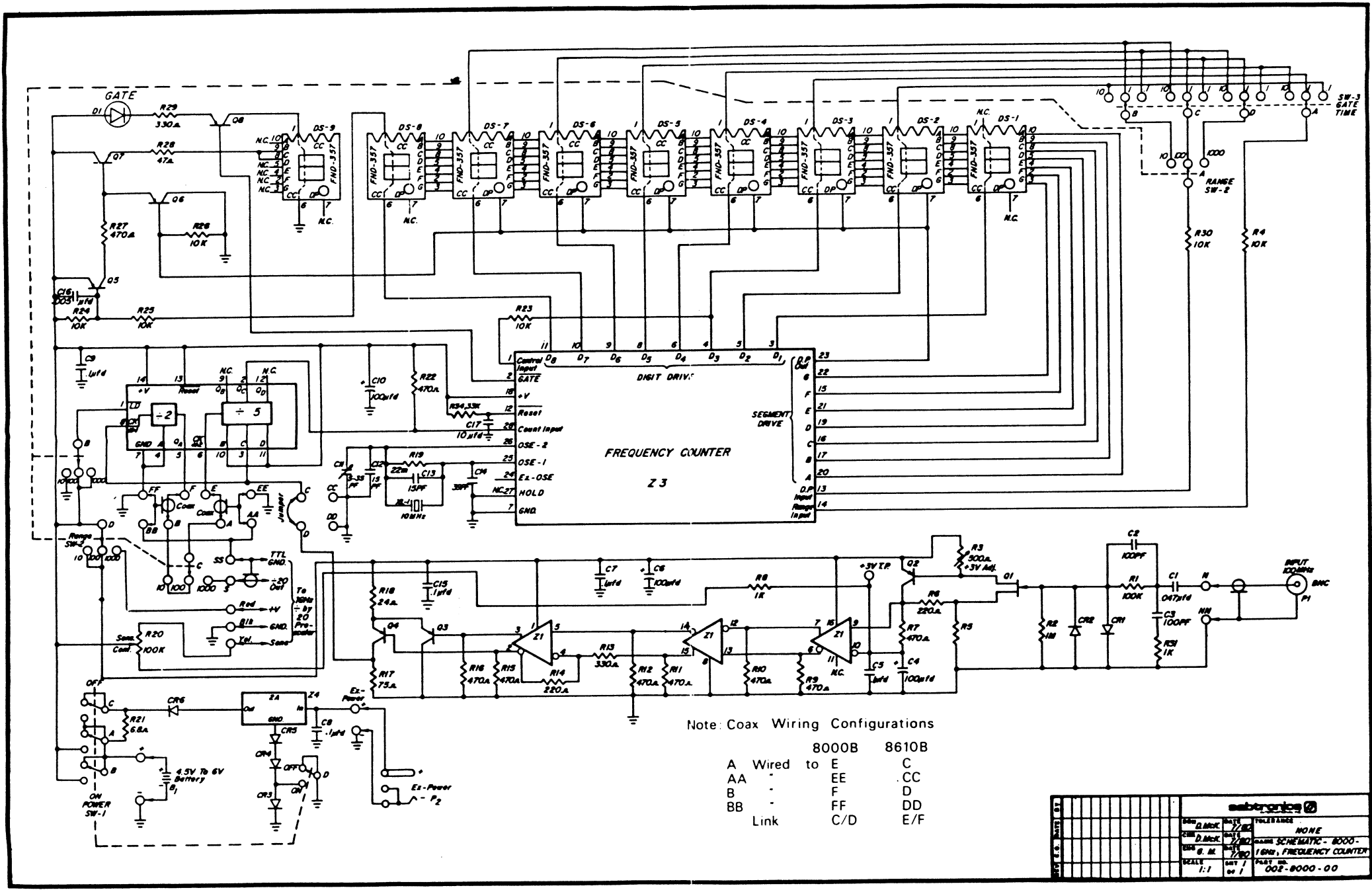

Note: Coax Wiring Configurations

8000B	8610B
A Wired to	E C
AA -	EE CC
B -	F D
BB -	FF DD
Link	C/D E/F

		DATE		REV	
REV	DATE	REV	DATE	REV	DATE
				REVISED	
				NONE	
				NAME SCHEMATIC - 8000-	
				TITLE 10MHz FREQUENCY COUNTER	
				SCALE 1:1	
				BY 1	
				Q02-8000-00	