

Fig. 1 Block diagram  
 Blockschaltbild  
 Schéma synoptique

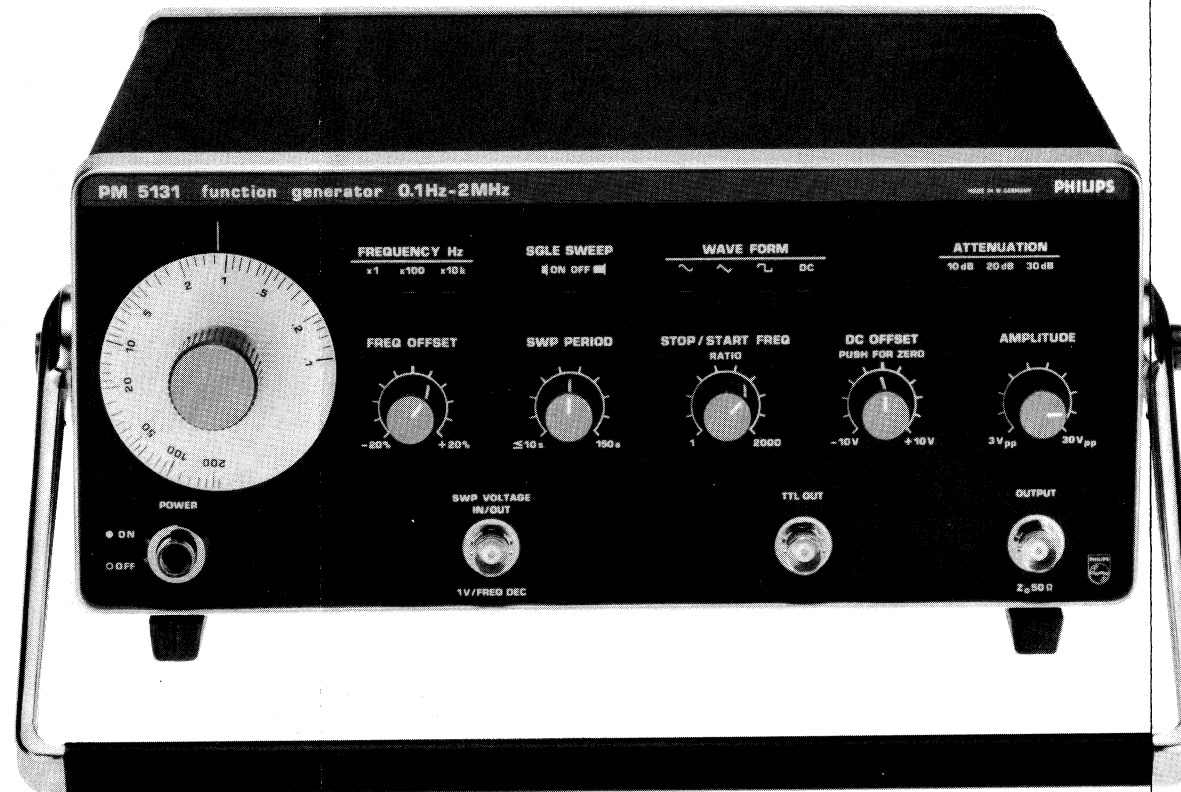

Fig. 2 Front view  
 Frontansicht  
 Face avant



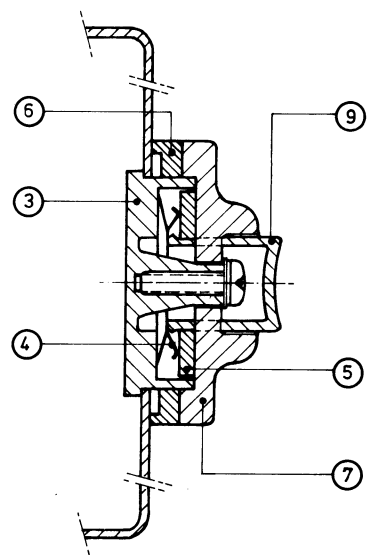
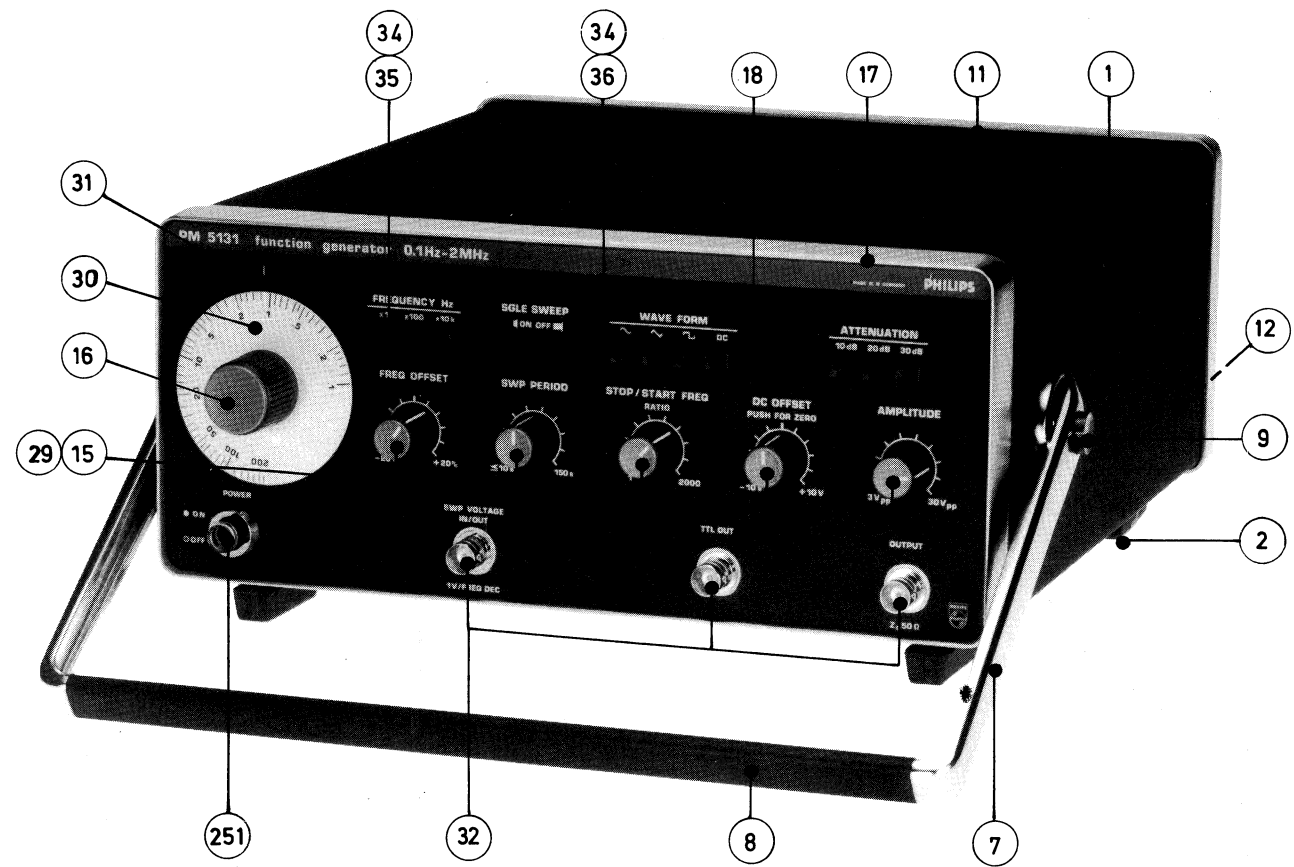

Fig. 3. Front view, mechanical parts

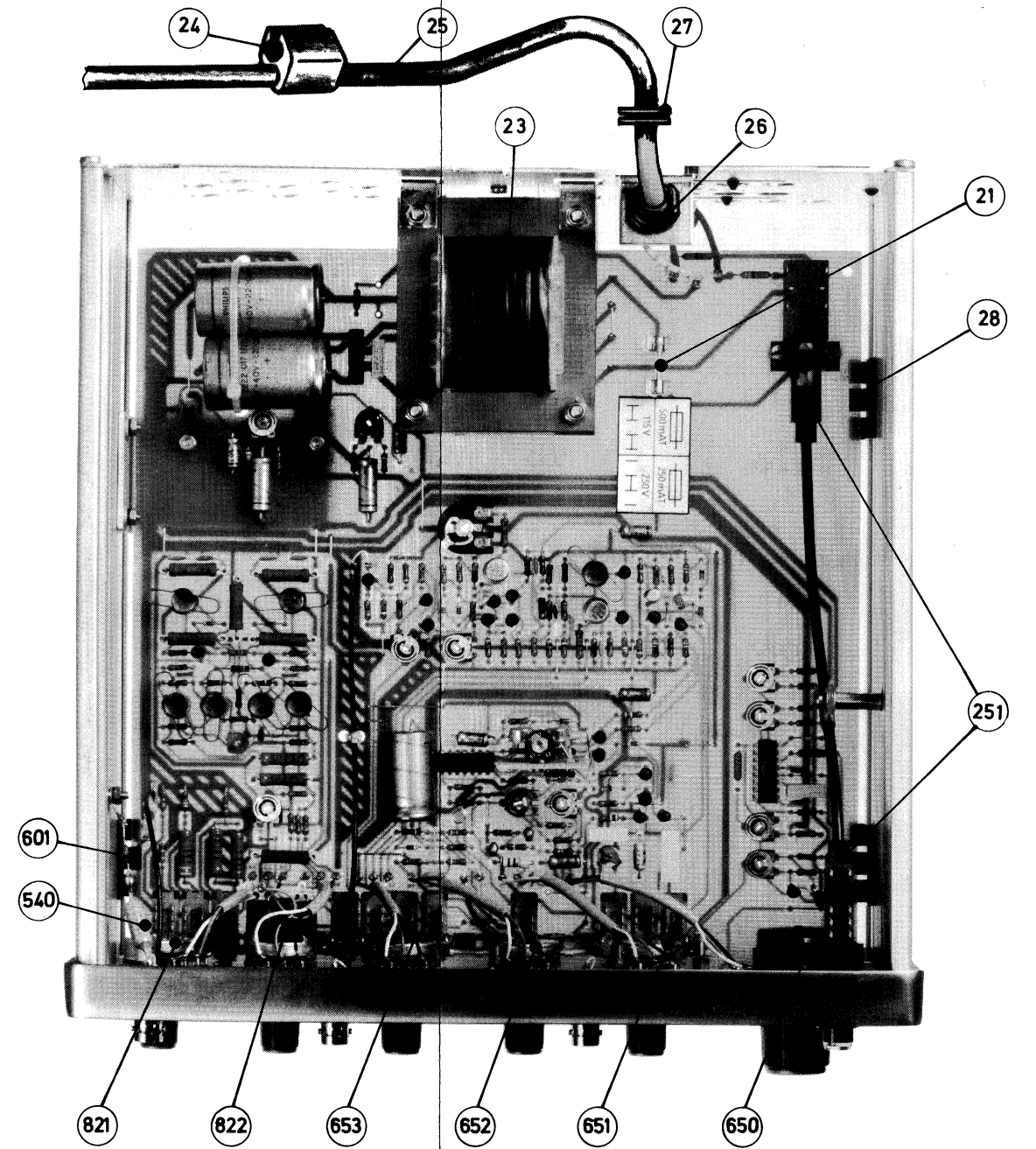

Fig. 4. Bottom view

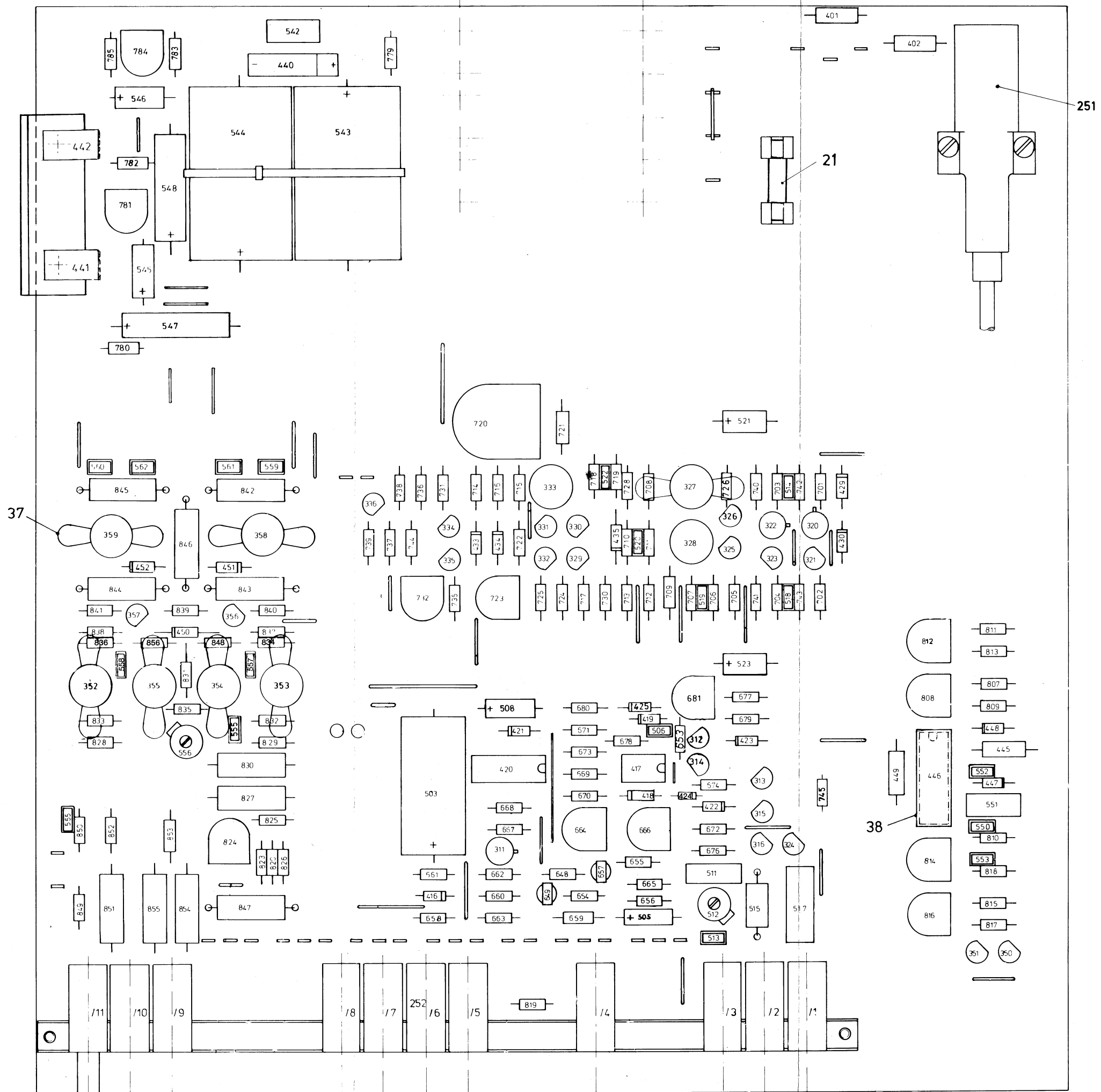
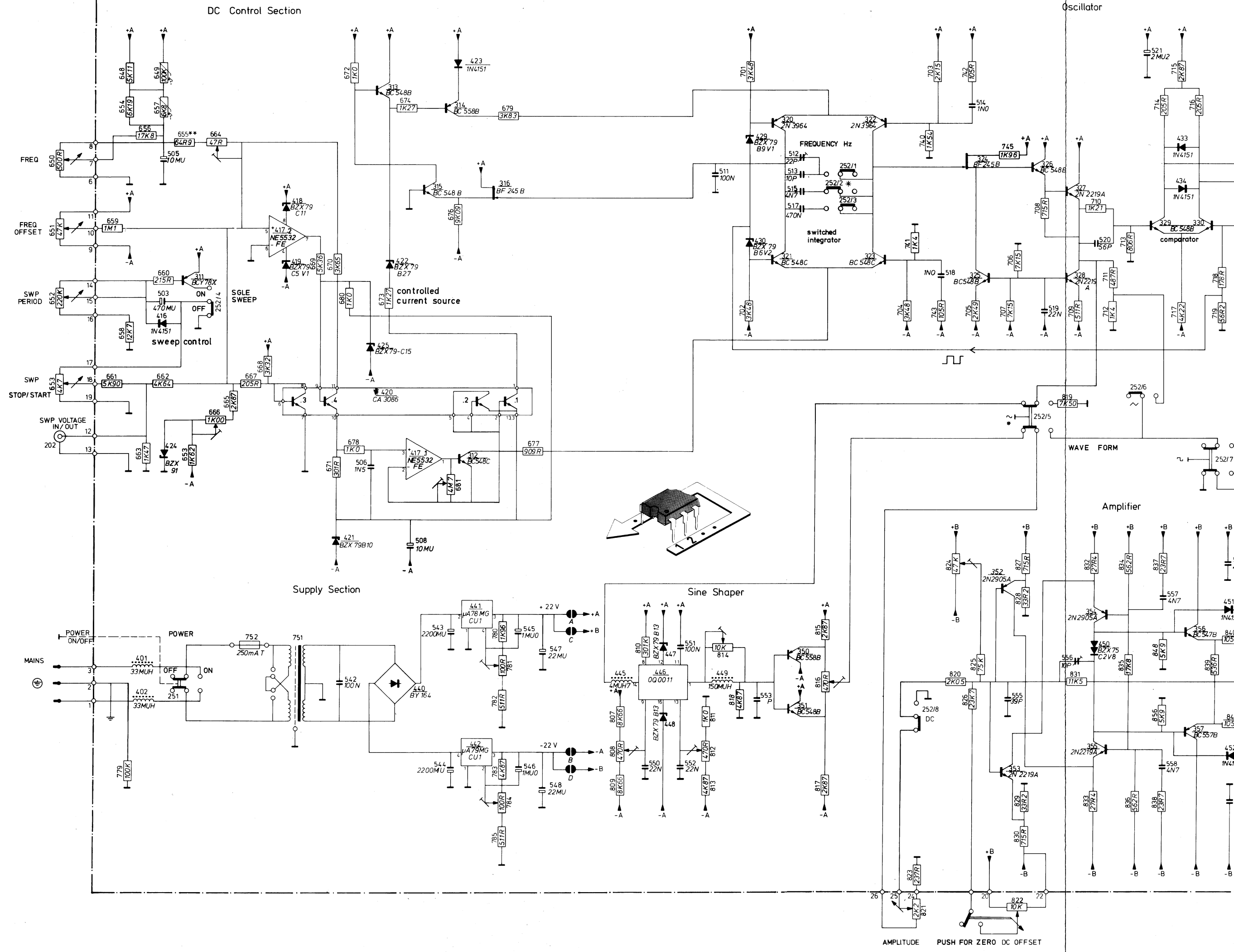

Fig. 5 Unit 1, component lay-out



DC Control Section

Oscillator

Supply Section

Sine Shaper

Amplifier

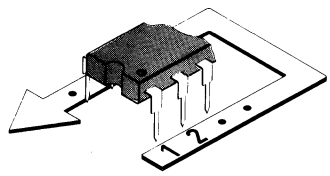
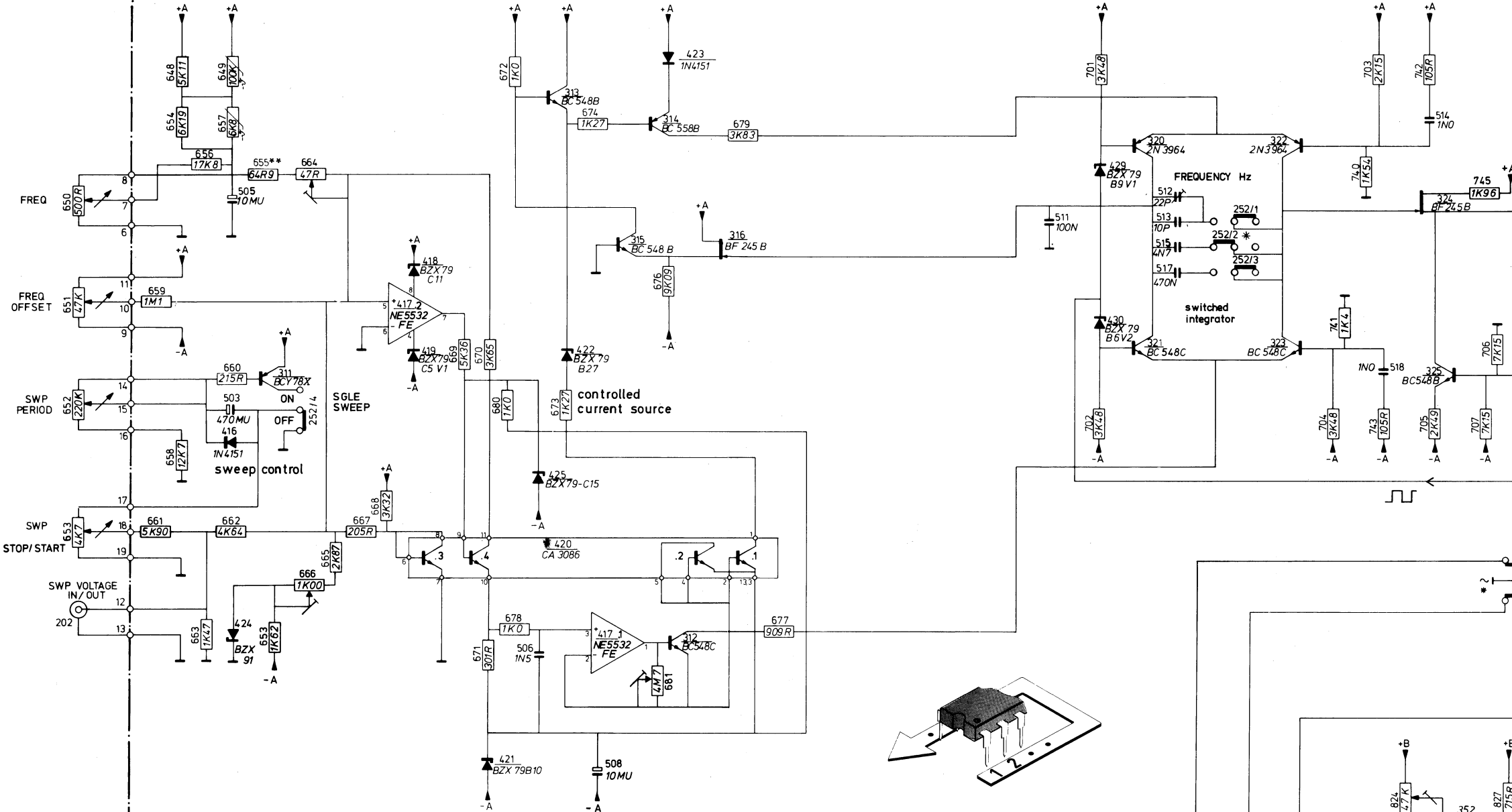

AMPLITUDE PUSH FOR ZERO DC OFFSET