

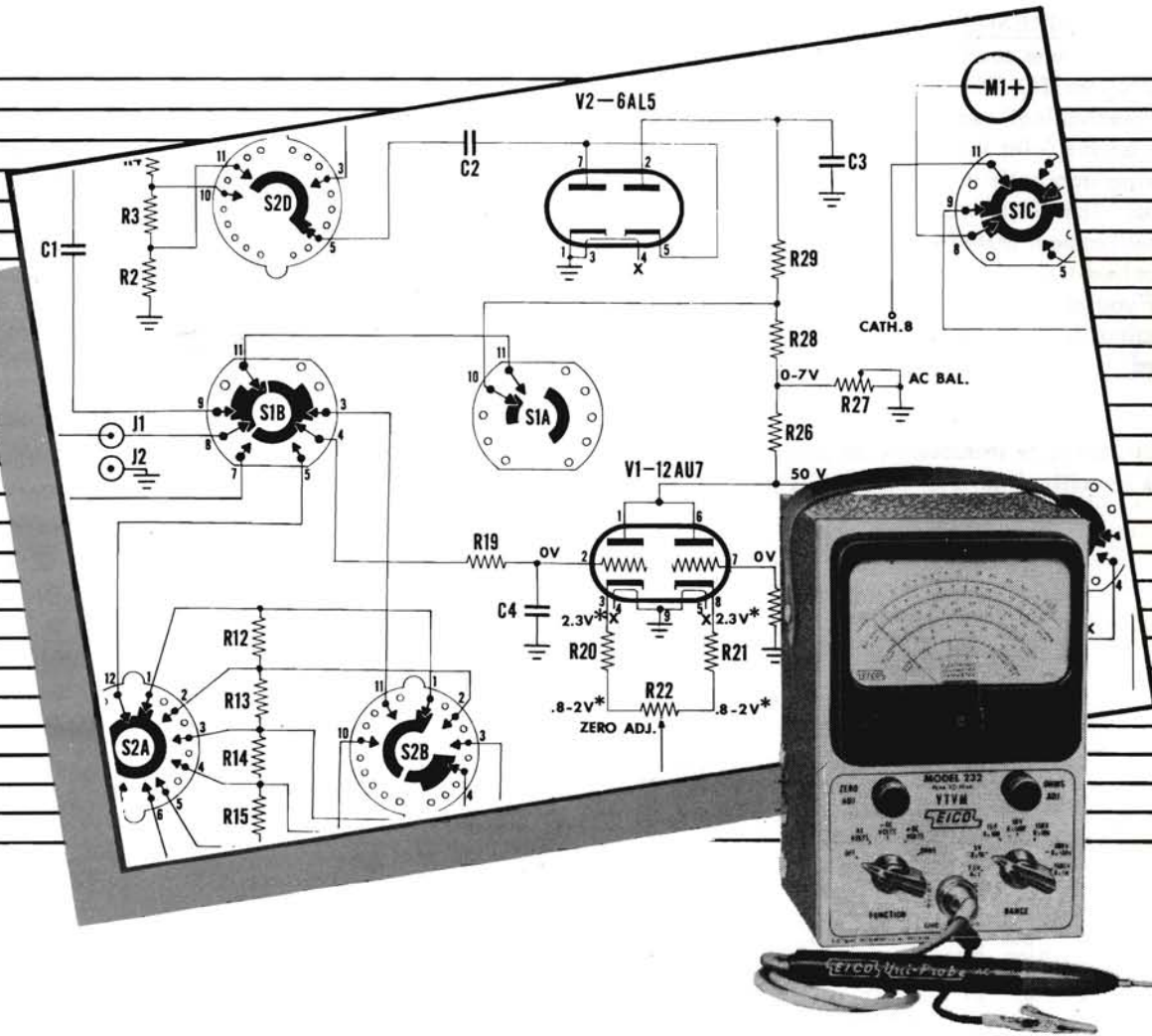

CONSTRUCTION MANUAL

Model 232 PEAK to PEAK VTVM



ELECTRONIC INSTRUMENT CO., Inc.

GENERAL INSTRUCTIONS

Care taken in the construction of this instrument will reward the constructor with many years of satisfactory service and greater confidence in his instrument. We urge you to not rush the construction, but to take all the time necessary for proper assembly, wiring, and adjustment.

Furthermore, we urge strongly that you follow the wire and parts layout shown in the pictorial diagrams as closely as possible. This is essential, because the position of wires and parts is quite critical in this instrument; changes may seriously affect the characteristics of the circuit.

UNPACKING THE KIT: Unpack the kit carefully and check each part against the parts list including those parts that are mounted to the chassis. If you have trouble identifying any parts, refer to the pictorial diagrams or the color code chart.

You may find that the value of a component will vary within the allowable circuit tolerance. As an example, a 470K ohm resistor may have substituted for it a 510K ohm resistor if the circuit is such as to allow this substitution. In general, resistors and controls have a tolerance of $\pm 20\%$ unless otherwise specified. Therefore, a 100K resistor may measure anywhere between 80K and 120K ohms. Tolerances on capacitors are even greater. Limits of +100% and -50% are usual for electrolytic capacitors.

CONSTRUCTION HINTS: USE THE BEST GRADE OF ROSIN CORE SOLDER ONLY, preferably one containing the new activated fluxes such as Kester "Resin-Five", Ersin "Multicore" or similar types. UNDER NO CIRCUMSTANCES USE ACID CORE SOLDER OR ACID FLUX since acid flux can cause serious corrosion. Before soldering make certain of a good mechanical connection. Use a clean, freshly tinned soldering iron, no smaller than 100 watts, and place the solder on the joint (not on the iron) so that the solder is melted by the heat from the joint itself. Do not remove the soldering iron until the solder flows and check to see that the resulting joint is smooth and shiny when the solder has cooled. There are two extremes to be avoided; too little heat and too much heat. If too little heat is applied, the joint will appear pitted and grey, indicating a rosin joint which is unsatisfactory. On the other hand, if too much heat is applied to a joint, the parts connected to it may either change value, lose their protective coating, or break down. If you are soldering close to a part, hold the lead between the part and the joint being soldered with the tip of a pair of longnose pliers. The pliers will conduct the heat away and prevent the component from being unduly overheated. If for any reason it is necessary to resolder a joint, be sure to use new solder.

It should also be noted that the leads on transformers, capacitors, and resistors are very often longer than necessary. These leads should be trimmed to the proper length when wiring. The instrument will not operate properly with overly long leads in critical parts of the circuit.

PARTS LIST

| CHK. STK.# | SYM. | DESCRIPTION | CHK. STK.# | SYM. | DESCRIPTION | CHK. STK.# | SYM. | DESCRIPTION |
|------------|--------|----------------------------|------------|---------|--------------------------------------|------------|------|----------------------------|
| 88019 | A1 | cabinet | 51005 | P2 | banana plug | 54008 | TB1 | term. strip 4 post |
| 81052 | A2 | chassis | 10407 | R1 | res., 1M Ω , 1/2W | 54003 | TB2 | term. strip 2 post |
| 80025 | A3 | panel | 11025 | R2 | res., 150K Ω , 1/2W, 1% | 54000 | TB3 | term. strip 1 post left |
| 87003 | A4 | handle | 11052 | R3 | res., 325K Ω , 1/2W, 1% | 90013 | V1 | tube, 12AU7 |
| 81053 | A5 | bracket, pot. | 11700 | R4 | res., 900K Ω , 1W, 1% | 90017 | V2 | tube, 6AL5 |
| 56503 | A6 | bracket, bat. | 11046 | R5 | res., 9M Ω , 1/2W, 1% | 57000 | W1 | line cord |
| 89523 | A7 | probe body | 11045 | R6 | res., 900K Ω , 1/2W, 1% | 58400 | W2 | kinkless wire |
| 56000 | B1 | battery 1 1/2V | 11039 | R7 | res., 90K Ω , 1/2W, 1% | 58403 | W3 | coax cable |
| 20003 | C1 | cap., 1mf - 1000V | 11038 | R8 | res., 9K Ω , 1/2W, 1% | 58000 | W4 | hook-up wire |
| 20007 | C4 | cap., .003mf - 400V | 11037 | R9 | res., 900 Ω , 1/2W, 1% | 58501 | W5 | wire, bare |
| 20012 | C2, C3 | cap., .025mf - 400V | 11044 | R10 | res., 90 Ω , 1/2W, 1% | 58300 | W6 | spaghetti |
| 23010 | C5 | cap., elec. 10mf - 150V | 11043 | R11 | res., 9.7 Ω , 1/2W, 1% | 97025 | XV1 | socket, 9 pin min. |
| 93003 | CR1 | rectifier, 50 ma | 11701 | R12 | res., 7M Ω , 1W, 1% | 97024 | XV2 | socket, 7 pin min. |
| 53006 | E1 | knob, bar | 11047 | R13 | res., 2M Ω , 1/2W, 1% | 40000 | | nut, #6 hex |
| 53001 | E2 | knob, small round | 11048 | R14 | res., 700K Ω , 1/2W, 1% | 40001 | | nut, 3/8 hex |
| 46005 | E3 | foot, rubber | 11026 | R15 | res., 200K Ω , 1/2W, 1% | 40005 | | nut, 10-24 hex |
| 46000 | E4 | grommet, 3/8 rubber | 11049 | R16 | res., 70K Ω , 1/2W, 1% | 40007 | | nut, #4-40 hex |
| 89520 | E5 | contact holder | 11050 | R17 | res., 20K Ω , 1/2W, 1% | 41000 | | screw, #6-32 X 1/4 |
| 44003 | E6 | spacer, fibre, large diam. | 11051 | R18 | res., 10K Ω , 1/2W, 1% | 41002 | | screw, #6 P.K. |
| 44002 | E7 | spacer, fibre, small diam. | 10033 | R19 | res., 3.3M Ω , 1/2W | 41008 | | screw, 6-32 X 1/2 |
| 42021 | E8 | washer, fibre, large diam. | 10406 | R20, 21 | res., 680 Ω , 1/2W | 41012 | | screw, 10-24 flat |
| 42020 | E9 | washer, fibre, small diam. | 16000 | R22, 30 | res., 2K Ω , var. | 41016 | | screw, #4-40 X 1/4 |
| 47002 | E10 | spring | 10521 | R23 | res., 47K, 1/2W | 41024 | | screw, 8-32 X 1/4 set |
| *89521 | E11 | metal lip | 10520 | R24 | res., 68K, 1/2W | 42000 | | washer, 3/8 lock |
| *89522 | E12 | nosepiece | 10034 | R25 | res., 4.7M Ω , 1/2W | 42001 | | washer, 3/8 flat |
| *89516 | E13 | indicator pin | 10503 | R26 | res., 33K Ω , 1/2W | 42002 | | washer, #6 lock |
| 50002 | J1 | male connector | 18015 | R27 | res., 10K Ω , variable w/tabs | 42006 | | washer, #6 fibre, shoulder |
| 50008 | J2 | lock, banana w/hardware | 10404 | R28 | res., 82M Ω , 1/2W | 42007 | | washer, #4 lock |
| 89517 | K1 | contact, rotor | 10524 | R29 | res., 18M Ω , 1/2W | 42022 | | washer, cup |
| 89518 | K2 | contact, phos. bronze | 18014 | R31, 32 | res., 2K Ω , variable w/tabs | 43000 | | lug, #6 gnd |
| 89519 | K3 | contact, phos. bronze | 60025 | S1 | switch, function | 45000 | | eyelet, #10 |
| 72004 | M1 | meter, 400 ua | 60024 | S2 | switch, range | 48000 | | button, plug, 3/8 |
| 51000 | P1 | female connector | 30012 | T1 | power transformer | 51502 | | clip, crocodile |

* factory pre-assembled

NOTE: When ordering replacement parts, please include all of the following information: 1) stock number and description given in parts list; 2) quantity; 3) model number of instrument; 4) serial number of instrument (on panel). This information will expedite the processing of your order and insure your receiving the correct replacement parts.

CONSTRUCTION PROCEDURE

CONSTRUCTION PROCEDURE: The step-by-step mounting and wiring procedure given below allows you to complete the mounting and wiring in a systematic manner. When you have completed a mounting or wiring instruction, check it off in the space provided. The method and location of mounting or the proper way to run a particular lead is shown in the accompanying drawings. To keep the drawings uncrowded, unnecessary repetition of mounting or wiring details may be omitted.

NOTE: In some cases, more than one connection is made to the same terminal. This condition is designated in the wiring instructions by the abbreviation (C), meaning that the connection should not be soldered until other leads have been connected. Where only one lead is connected to a terminal, or where the last of several leads is connected, the abbreviation (S) will be given. (S) means that the joint should be soldered.

MOUNTING PROCEDURE

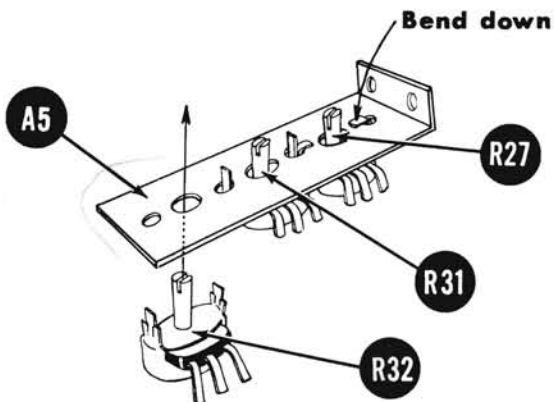

Fig. 1

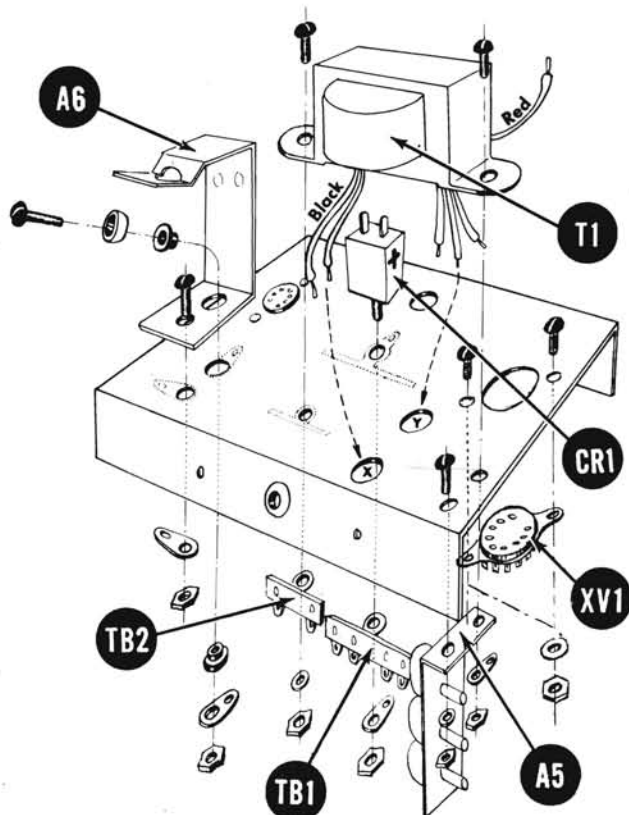

Fig. 2

- (-) Fig. 1. Mount the 10K Ω AC BAL. potentiometer, R27, on potentiometer mounting bracket, A5. Bend tabs in towards the shaft as shown.
- (-) Fig. 1. Likewise, mount the 2K Ω DC CAL. potentiometer, R31.
- (-) Fig. 1. In a similar manner, mount the 2K Ω AC CAL. potentiometer, R32.
- (-) Fig. 2. Mount the 9 pin miniature socket, XV1, with 2 each #4-40 screws, #4 hex nuts and #4 washers. See Fig. 3 for keyway location.
- (-) Fig. 2. Mount the 7 pin miniature socket, XV2, with 2 each #4-40 screws, #4 hex nuts, and #4 washers. A one post left terminal strip, TB3, is mounted with XV2. See Fig. 3 for location.
- (-) Fig. 2. Insert 3/8" rubber grommet for line cord in hole in center of rear chassis apron.
- (-) Fig. 2. Mount the selenium rectifier CR1 with a 6/32 hex nut. Position the 4 post terminal strip TB1 and the ground lug under the nut as shown.
- (-) Fig. 2. Mount the battery clip A6 with a 6-32 X 1/4 screw and a 6-32 hex nut. Position gnd. lug under nut as shown. Line up the two empty holes before you tighten nut.
- (-) Fig. 2. Mount the cup washer to the battery clip. Use a 6-32 X 1/2 screw, two #6 shoulder fiber washers and a 6-32 hex nut. Position a #6 ground lug under nut as shown.
- (-) Fig. 2. Mount the pre-assembled potentiometer bracket A5 to the chassis. Use a 6-32 X 1/4 screw, a #6 lockwasher and a 6-32 hex nut. Line up two empty holes before you tighten nut.
- (-) Fig. 2. Mount the power transformer T1 to the chassis. Pass black leads thru hole "X" and the leads on the other side of the transformer thru hole "Y" except one red. Use two 6-32 X 1/4 screws, one #6 lockwasher and two 6-32 hex nuts. Place two post terminal strip TB2 as shown and under other hex nut position a #6 ground lug.

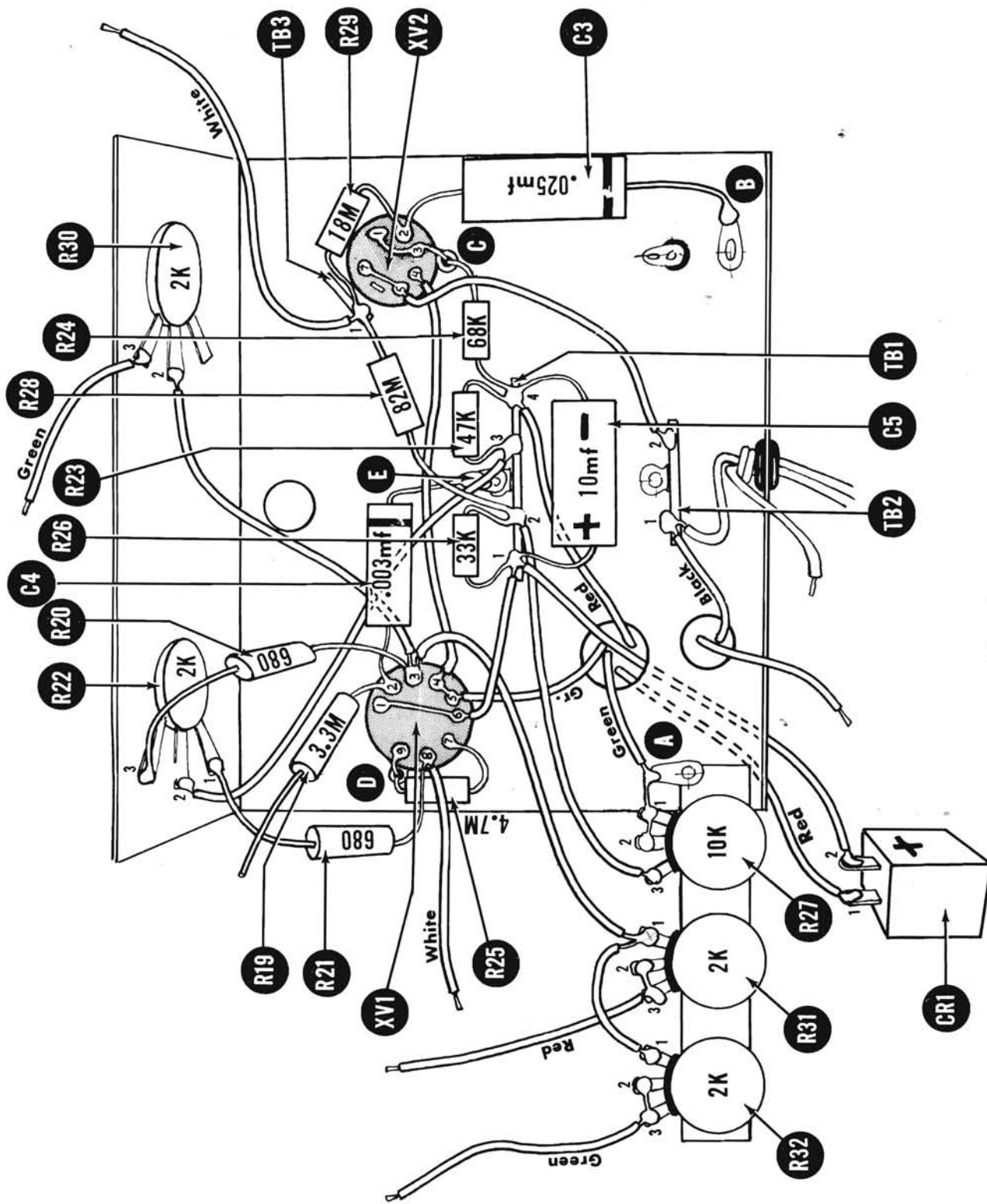

Fig. 3

- (✓) Fig. 3. Mount the 2 K Ω Zero Adj. potentiometer R22 with two 3/8 hex nuts, one 3/8 lockwasher and one 3/8 flat washer. This is a temporary mounting.
- (✓) Fig. 3. Likewise, mount the 2 K Ω Ohms Adj. potentiometer R30.
- (✓) Fig. 3. Connect green lead of power transformer T1 to ground lug "A" (C).
- (✓) Fig. 3. Connect a short length of bare wire from gnd lug "A" (S) to R27-2 (S) thru R27-1 (S).
- (✓) Fig. 3. Connect green lead of power transformer T1 to XV1-4 (C) thru XV1-5 (S).
- (✓) Fig. 3. Connect red lead of power transformer T1 to TB1-4 (C).
- (✓) Fig. 3. Connect the other red lead of power transformer T1 to CR1-1 (S). This lead is on top side of chassis.
- (✓) Fig. 3. Connect a length of red hook-up wire from CR1-2 (S) to TB1-1 (C).
- (✓) Fig. 3. Connect black lead of power transformer T1 to TB2-1 (C).
- (✓) Fig. 3. Connect a length of green hook-up wire from XV1-4 (S) to XV2-4 (S).
- (✓) Fig. 3. Connect the positive (+) lead of the 10mf electrolytic capacitor C5 to TB1-1 (C) and the negative lead (-) to TB1-4 (C).
- (✓) Fig. 3. Connect a short length of red hook-up wire from TB1-1 (C) to XV1-1 (S), thru XV1-6 (S).
- (✓) Fig. 3. Connect the 33 K Ω resistor R26 from TB1-1 (S) to TB1-2 (C).
- (✓) Fig. 3. Connect a length of red hook-up wire from TB1-2 (C) to R27-3 (S).
- (✓) Fig. 3. Connect the 82 M Ω resistor R28 from TB1-2 (S) to TB3-1 (C).
- (✓) Fig. 3. Connect the 18 M Ω resistor R29 from TB3-1 (C) to XV2-2 (C). Use spaghetti.
- (✓) Fig. 3. Connect a 5 1/2 in. length of white hook-up wire to TB3-1 (S).
- (✓) Fig. 3. Connect a .025 mf capacitor C3 from XV2-2 (S) to ground lug "B" (S). Use spaghetti.
- (✓) Fig. 3. Connect a short length of bare wire from XV2-1 (S) to lug "C" (C) on XV2 thru XV2-3 (S).
- (✓) Fig. 3. Connect the 68K Ω resistor R24 from TB1-4 (C) to lug "C" (S) on XV2.
- (✓) Fig. 3. Connect the 47 K Ω resistor R23 from TB1-4 (S) to TB1-3 (C).
- (✓) Fig. 3. Connect a length of white hook-up wire from TB1-3 (S) to R22-2 (S).
- (✓) Fig. 3. Connect a length of white hook-up wire from TB2-2 (C) to XV2-7 (S), thru XV2-5 (S).
- (✓) Fig. 3. Connect the 4.7M Ω resistor R25 from XV1-7 (S) to lug "C" (C) on XV1. Use spaghetti.
- (✓) Fig. 3. Connect a short length of bare wire from XV1-9 (S) to lug "D" (S) on XV1.
- (✓) Fig. 3. Connect a length of green hook-up wire from R30-2 (S) to XV1-3 (C).
- (✓) Fig. 3. Connect a 680 Ω resistor from XV1-3 (C) to R22-3 (S).
- (✓) Fig. 3. Connect a length of green hook-up wire from XV1-3 (S) to R31-1 (C).
- (✓) Fig. 3. Connect a length of green hook-up wire from R31-1 (S) to R32-1 (S).
- (✓) Fig. 3. Connect the .003 mf capacitor C4 from XV1-2 (C) to ground lug "E" (S). Use spaghetti.
- (✓) Fig. 3. Connect the 3.3 M Ω resistor R19 to XV1-2 (S).
- (✓) Fig. 3. Connect the other 680 Ω resistor R21 from XV1-8 (C) to R22-1 (S).
- (✓) Fig. 3. Connect a 3 in. length of white hook-up wire to XV1-8 (S).
- (✓) Fig. 3. Connect a 4 in. length of green hook-up wire to R30-3 (S).
- (✓) Fig. 3. Connect a 2 1/2 in. length of red hook-up wire to R31-2 (S), thru R31-3 (S).
- (✓) Fig. 3. Connect a 2 1/4 in. length of green hook-up wire to R32-2 (S), thru R32-3 (S).
- (✓) Fig. 3. Insert line cord in grommet and knot 4" from stripped ends. Connect one lead to TB2-1 (S).

PREWIRING OF RANGE SWITCH S2

IMPORTANT: Before prewiring S2, see Fig. 4 and note the position of lug "F" on the rear wafer in relation to how the switch is being viewed in the drawing. This should enable you to correctly identify the contacts on the actual switch that correspond to the contacts shown in Fig. 4.

- (✓) Fig. 4. Connect a length of hook-up wire from A5 (C) to B10 (S). The A side of the wafer is closest to the detent mechanism.
- (✓) Fig. 4. Connect a length of bare wire from A6 (S) to X6 (C). The X designation will be used for the switch wafer containing the dummy lugs.
- (✓) Fig. 4. Connect a length of bare wire from A4-B4 (S) to X4 (C). When the double designation A4-B4 is used, it means the two switch lugs are electrically connected together by the rivet holding them to the wafer.
- (✓) Fig. 4. Connect a length of bare wire from A2-B2 (S) to X2 (C).
- (✓) Fig. 4. Connect the 10 K Ω resistor R18 from ground lug "G" (S) to A7 (C).
- (✓) Fig. 4. Connect the 20 K Ω resistor R17 from A7 (S) to X6 (C).
- (✓) Fig. 4. Connect the 70 K Ω resistor R16 from X6 (S) to A5 (C).
- (✓) Fig. 4. Connect the 200 K Ω resistor R15 from A5 (S) to X4 (C).
- (✓) Fig. 4. Connect the 700 K Ω resistor R14 from X4 (S) to A3-B3 (C).
- (✓) Fig. 4. Connect the 2 M Ω resistor R13 from A3-B3 (S) to X2 (C).
- (✓) Fig. 4. Connect the 7 M Ω resistor R12 from X2 (S) to A1-B1 (C).
- (✓) Fig. 4. Connect a 5 in. length of green hook-up wire to A1-B1 (S).
- (✓) Fig. 4. Connect a 4 in. length of white hook-up wire to A12 (S).
- (✓) Fig. 4. Connect a 6 in. length of red hook-up wire to B11 (S).

RANGE SWITCH S2

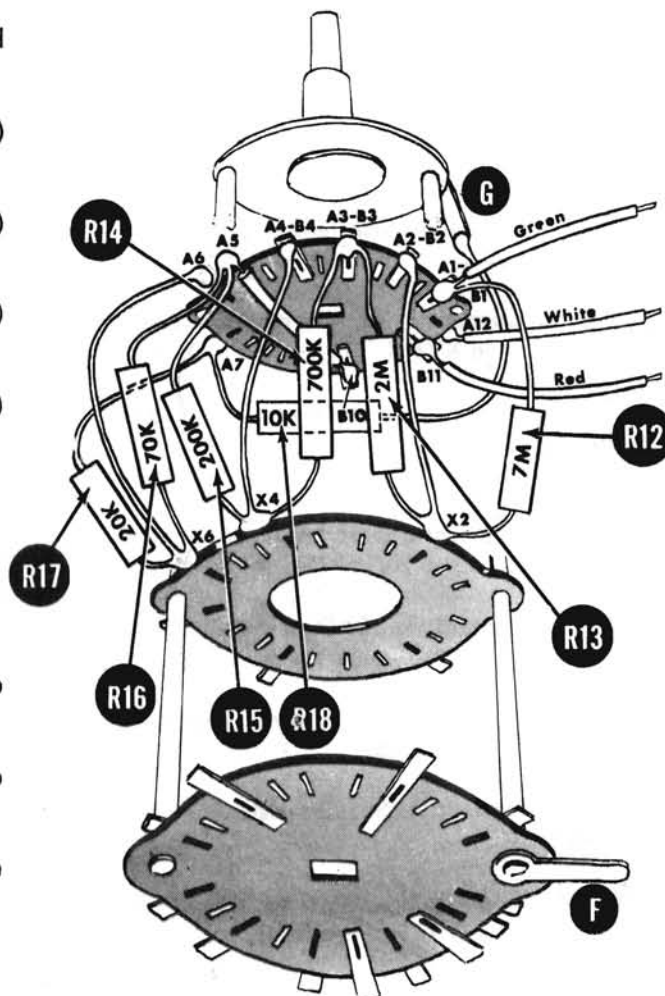

Fig. 4

PREWIRING OF RANGE SWITCH CONTINUED

() Fig. 5. Note that in Fig. 5 the switch is being viewed from the side that faced away from the observer in Fig. 4. Again note the position of lug "F" on the rear wafer in relation to how the switch is being viewed in the drawing. This should enable you to correctly identify the contacts on the actual switch that correspond to the contacts shown in Fig. 5.

RANGE SWITCH S2

- () Fig. 5. Connect a length of bare wire from C11 (S) to X11 (C).
- () Fig. 5. Connect a length of bare wire from C9 (S) to X9 (C).
- () Fig. 5. Connect a length of bare wire from C7 (S) to X7 (C).
- () Fig. 5. Connect the 9MΩ resistor R5 from C12 (S) to X11 (C).
- () Fig. 5. Connect the 900 KΩ (1/2 watt) resistor R6 from X11 (S) to C10 (C).
- () Fig. 5. Connect the 90 KΩ resistor R7 from C10 (S) to X9 (C).
- () Fig. 5. Connect the 9 KΩ resistor R8 from X9 (S) to C8 (C).
- () Fig. 5. Connect the 900 Ω resistor R9 from C8 (S) to X7 (C).
- () Fig. 5. Connect the 90 Ω resistor R10 from X7 (S) to C6 (C).
- () Fig. 5. Connect the 9.7 Ω resistor R11 to C6 (S).
- () Fig. 5. Connect the 150 KΩ resistor R2 from gnd lug F (S) to D11 (C).
- () Fig. 5. Connect the 325 KΩ resistor R3 from D11 (S) to D10 (C).
- () Fig. 5. Connect the 900 KΩ (1 watt) resistor R4 from D10 (S) to D3 (C).
- () Fig. 5. Connect the .1 mf capacitor C1 to D3 (S).
- () Fig. 5. Connect a .025 mf capacitor C2 to D5 (S).
- () Fig. 5. Connect a 3 in. length of green hook-up wire to C1 (S).

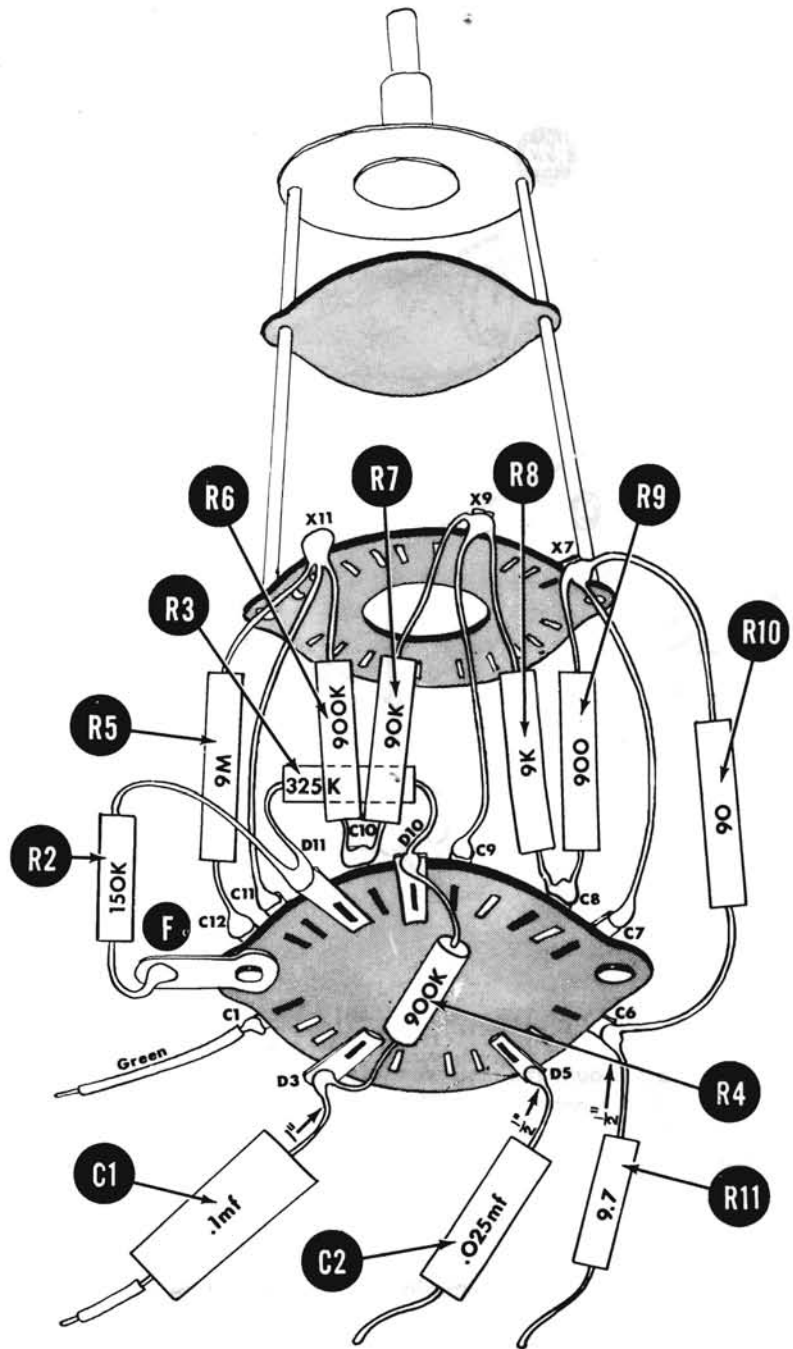

Fig. 5

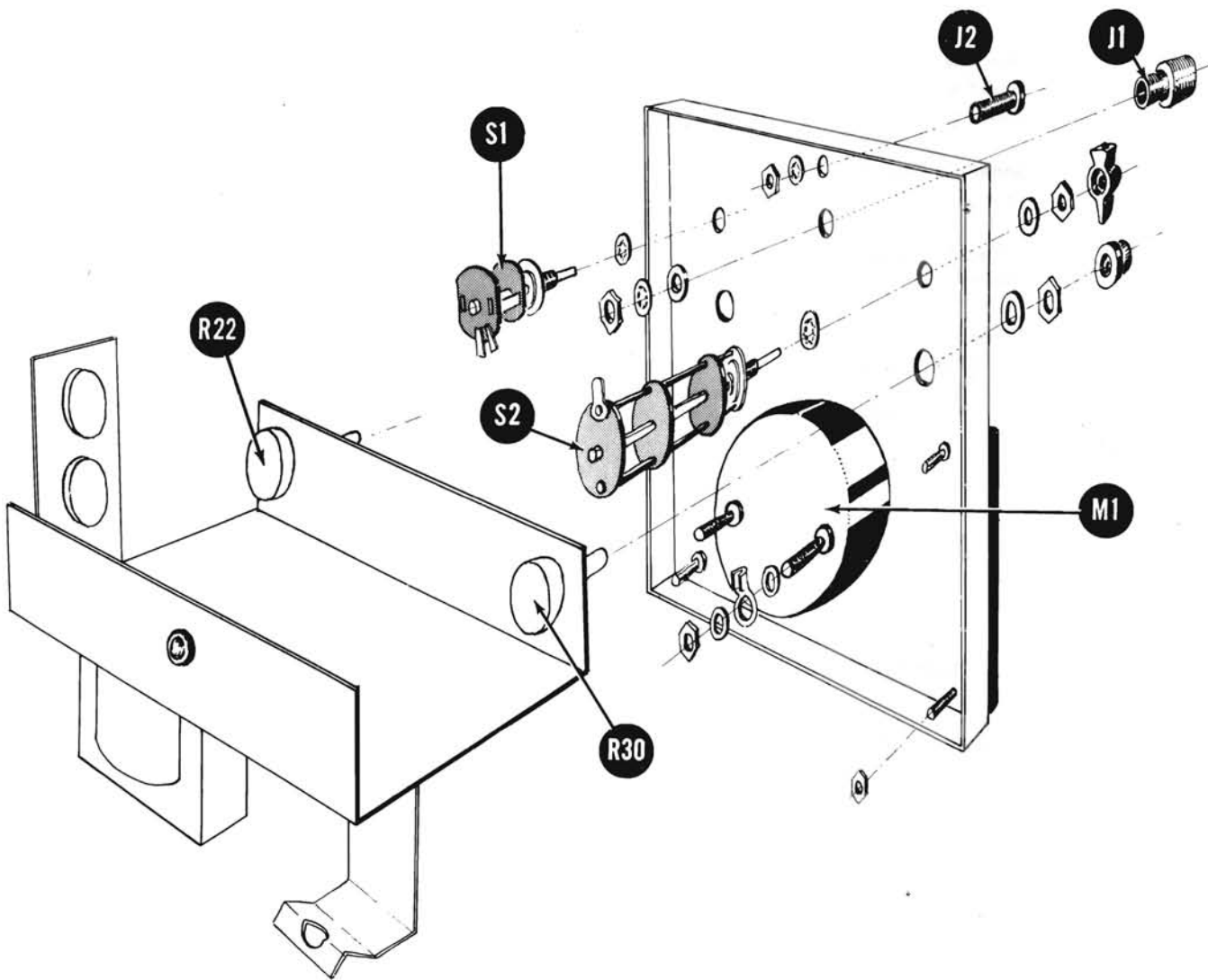

Fig. 6

- () Fig. 6. Mount the male co-axial connector J1 on the panel. A little pressure is required to imbed the knurled edge in the panel hole. Use a 3/8 flat fibre washer, a 3/8 lockwasher and a 3/8 hex nut.
- () Fig. 6. Mount the banana jack J2 with a 1/4" lockwasher and a 1/4"-28 hex nut.
- () Fig. 6. Mount the meter movement M1 on the panel with the hardware supplied in the box it is packed in.
- () Fig. 6. Mount the remaining hardware found in the box on the meter terminals.
- () Fig. 6. Remove from controls R22 and R30, the 3/8" hex nut and flat washer on the outer side of the front chassis apron. Fit the shafts of R22 and R30 through the mating holes in the panel and fasten panel to chassis by restoring the hardware previously removed. Be certain that no hardware of any kind has been left between the panel and the front chassis apron.
- () Fig. 6. Mount the function switch S1 with one 3/8" hex nut, one 3/8" lockwasher and one 3/8" flat washer. Switch is in correct position when the two lugs on the back side of the rear wafer are facing toward the top of the panel.

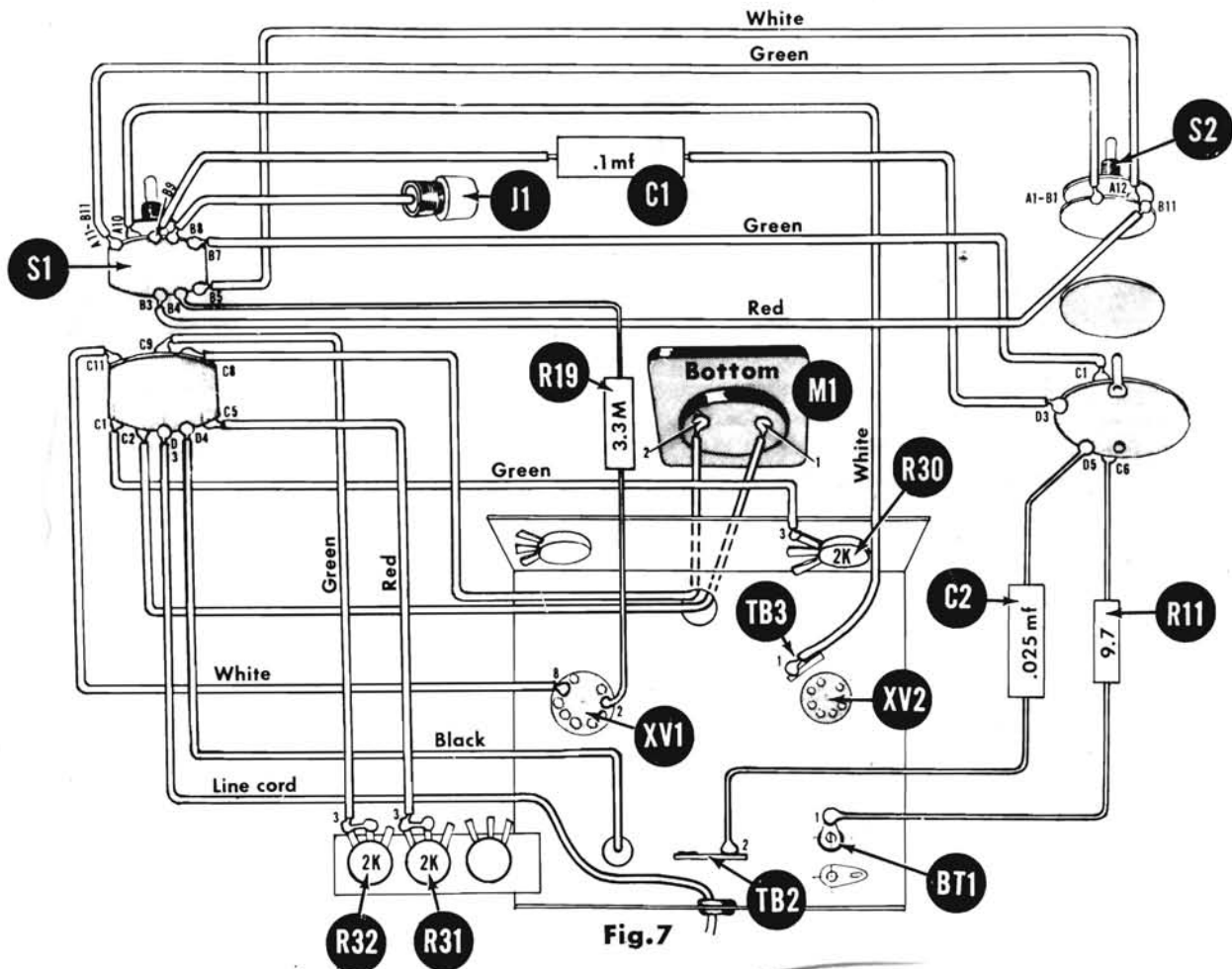

Fig. 7

- () Fig. 7. Connect the 3.3M Ω resistor R19 from XV1-2 to S1-B4 (S).
- () Fig. 7. Connect the white wire from XV1-8 to S1-C11 (S).
- () Fig. 7. Connect the white wire from TB3-1 to S1-A10 (S).
- () Fig. 7. Connect the red wire from R31-3 to S1-C5 (S).
- () Fig. 7. Connect the green wire from R32-3 to S1-C9 (S).
- () Fig. 7. Connect the free lead of the line cord to S1-D3 (S).
- () Fig. 7. Connect the black lead of power transformer T1 to S1-D4 (S).
- () Fig. 7. Connect the green wire from R30-3 to S1-C1 (S).
- () Fig. 7. Connect a 5 in. length of red hook-up wire from M1-1 (S) to S1-C2 (S). Pass lead thru chassis hole.
- () Fig. 7. Likewise, connect a 5 in. length of green hook-up wire from M1-2 (S) to S1-C8 (S).
- () Fig. 7. Connect a length of hook-up wire from J1 (S) to S1-B8 (S). Pass wire thru jack and solder to metal ring in center of plastic.
- () Fig. 7. Mount the prewired range switch S2 to the panel. Switch is in correct position when lug F points to bottom of panel.
- () Fig. 7. Connect the green wire from S2-A1 - B1 to S1-A11 - B11 (S).
- () Fig. 7. Connect the white wire from S2-A12 to S1-B5 (S).
- () Fig. 7. Connect the red wire from S2-B11 to S1-B3 (S).
- () Fig. 7. Connect the green wire from S2-C1 to S1-B7 (S).
- () Fig. 7. Connect the .1 mf capacitor C1 from S2-D3 to S1-B9 (S).
- () Fig. 7. Connect the .025 mf capacitor C2 from S2-D5 to TB2-2 (S).
- () Fig. 7. Connect the 9.7 Ω resistor R11 from S2-C6 to BT1-1 (S).

UNI-PROBE ASSEMBLY

- (✓) Fig. 8. Slip the small diameter fiber tube E7 over the metal stud E11 protruding from the nose-piece assembly.
- (✓) Fig. 8. Slip the large diameter fiber washer E8 over E7 and seat it on the blunt-end of the nose-piece E12.
- (✓) Fig. 8. Slip the compression spring E10 over the fiber tube E7.
- (✓) Fig. 8. Hold the spring E10 compressed so that the threaded end of the metal stud E11 is exposed. In the order given, slip the following parts over the threaded end of the stud: the small diameter fiber washer E9, the brass rotor contact K1, a #6 split washer, and a #6-32 hex nut. Tighten the nut and then release the spring.

Note: Before proceeding, make sure that the large diameter fiber washer E8 is not caught between small diameter fiber tube and the blunt end of the nose-piece by seeing whether E8 can be moved up E7, simultaneously compressing the spring E10. Also make sure that the opposite end of the spring is not caught between E7 and the small diameter fiber washer E9 by seeing whether this end of the spring can be drawn entirely away from E9.

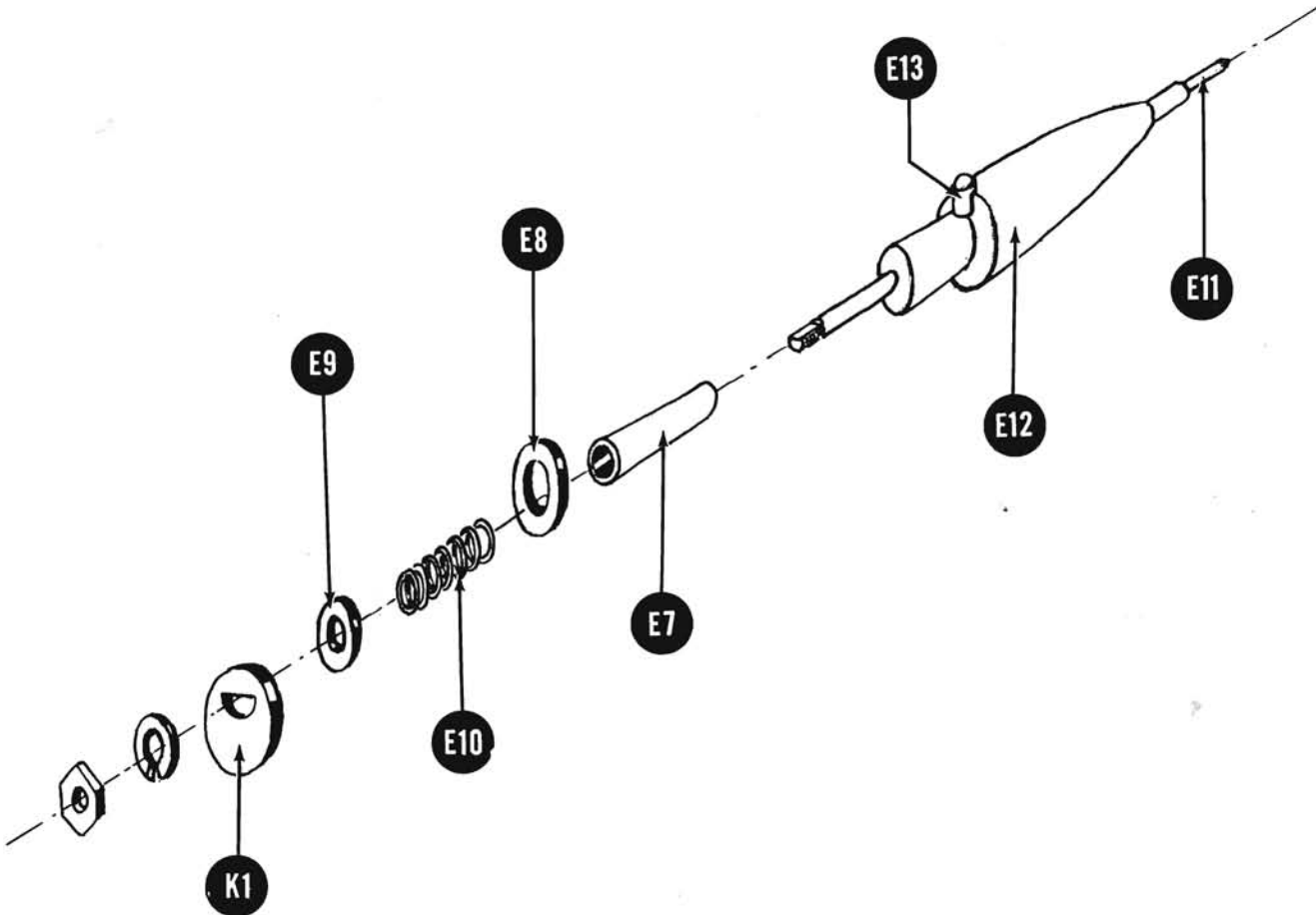

Fig. 8

- (✓) Fig. 9. Study the figure before proceeding with the assembly. Phosphor-bronze contacts K2 and K3 are formed differently and may not be interchangeable from the relative positions shown in the drawing. K2 and K3 can most easily be told apart by the small hole to be found in K3 but not in K2. Assemble as follows: Hold the black fiber contact holder E5 as shown in the figure. Lay K2 against the flat surface X of E5, position it as shown in Fig. 9A, and hold it there. Then lay K3 against the parallel flat surface of E5 underneath, position it as shown in Fig. 9B, and hold K3 in place also. Next catch the free ends of K2 and K3 in the large diameter Fiber tube E6, and then move E6 down over K2 and K3 to pin them against the flat surfaces of E5. This is a fairly tight fit and some force is required. E6 should finally rest against the shoulder of E5 past which it can not be moved.

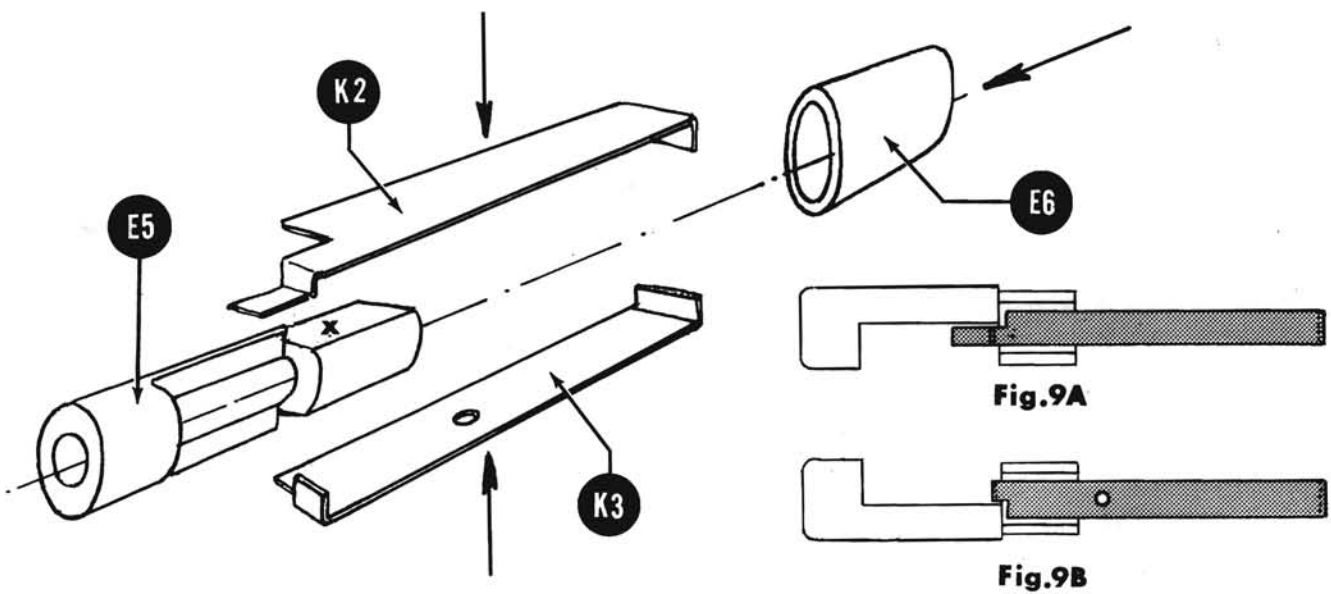

Fig. 9

(-) Fig. 10. Position the contact holder assembly just completed so that the free ends of contacts K2 and K3 are at the left with K3 (small hole) on top. If the contact holder assembly, positioned as just described, is held at eye level in front of you, it will be seen as shown in Fig. 10. Position the body of the 1 MΩ resistor R1 as shown, and pass one lead through the small hole in K3. Then trim off the excess lead and solder the connection between R1 and K3. Connect the other lead of R1 to the extension of the bottom contact K2 by first shaping the lead to lay flat against the K2 extension and then bending it back underneath. Close the U-shaped bend in the lead with a pliers to grip the K2 extension firmly and trim off the lead. The connection will be soldered in the next step.

(-) Fig. 10. At one end of the co-axial cable strip away 1/2" of outside insulation and outer metal braid and 1/4" of inner insulation to expose the inner conductor. Insert the co-axial cable end so prepared in E5 as shown, and solder the inner conductor to the extension of contact K2, to which one lead of R1 was previously connected.

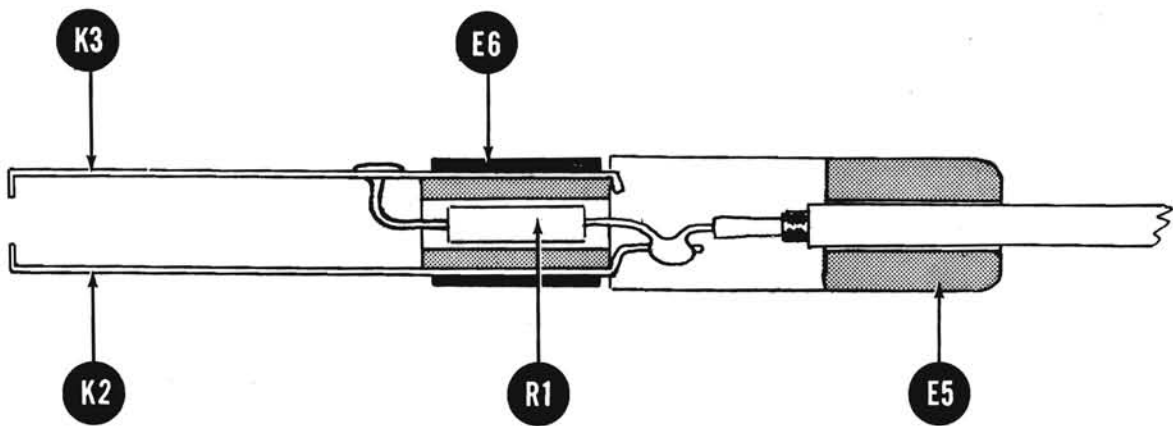

Fig. 10

() Fig. 11. Slip the free end of the co-axial cable into the notched end of the probe body A7. Move the probe body down the cable over the contact holder assembly until only the ends of contacts K2 and K3 protrude from it as shown. Push the fiber washer E8 away from the blunt end of the nose-piece, simultaneously compressing spring E10, and hold E8 in this position with one hand. Fold the palm of the other hand around the probe body with the thumb and forefinger of this hand in a position to press the ends of K2 and K3 together. Now align the

two sections of the probe as shown in Fig. 11, the jaws formed by the ends of contacts K2 and K3 pressed closed on fiber tube E7, between E8 and the blunt end of the nose-piece. Release fiber washer E8 (and the spring) to pin the closed jaws formed by contacts K2 and K3 against the blunt end of the nose-piece but continue to press the jaws closed or one or both of the contacts will slip out. Now use the hand that has just been freed to move the probe body down the contacts to the jaws formed by the ends, releasing your pressure on the jaws only when the end of the probe body is sufficiently close to the jaws to ensure that the contacts will not spring free. Then move the probe body down on the nose piece until either one of the notches engages the white pin. Next, grasp the probe body in one hand, and close the 3rd, 4th, and 5th fingers of the other hand about the co-axial cable at a point about 2" from the end of the probe body. Pull on the cable until the emerging end of the black fiber contact holder E5 can be gripped by thumb and forefinger. Maintaining your grip on the cable, rotate E5 until the #8 threaded hole is directly under the #8 hole in the probe body and insert the #8 set screw. Turn the screw until its head is just below the surface of the probe body.

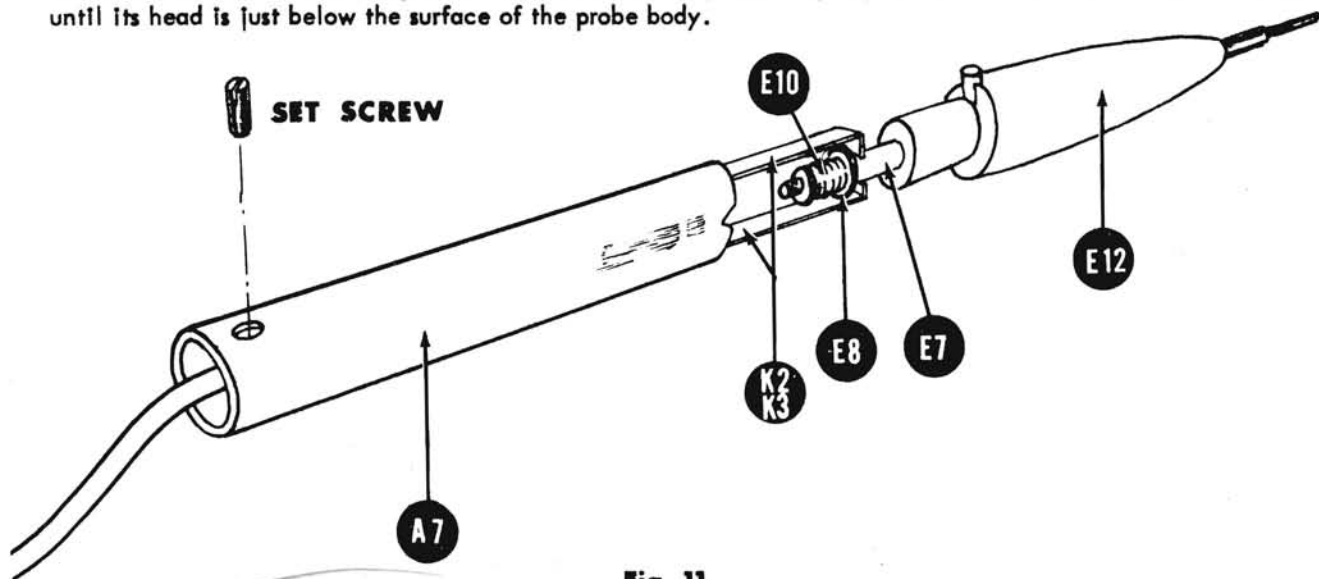

Fig. 11

(*) Fig. 12. Connect the female co-axial connector to the other end of the UNI-PROBE cable as follows: Strip the cable end exactly as shown. Disassemble the connector. Slip the stripped cable end into the larger diameter end of the spring and then solder the small diameter end of the spring to the very edge of the metal braid. Slip the connector ring over the cable end past the spring, unthreaded end first. Pass the cable end thru the tapered end of the connector (threading the inner conductor thru the eyelet in the bakelite disc) until passage is stopped by the larger spring diameter. Tighten the set screw in the connector body so that the cable and spring will be secured mechanically. Solder the inner conductor of the cable to the eyelet in the bakelite disc and trim off excess lead. A section of the internally threaded part of the connector ring should extend past the connector body to enable coupling to the male connector on the panel.

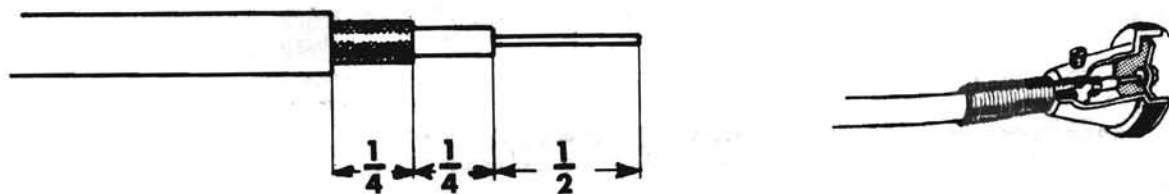

Fig. 12

- () Fig. 13. Make up the Ground Cable as follows: Strip 1/2" of insulation from both ends of the black kinkless wire. Connect and solder the alligator clip to one end (crimp U-shaped groove in clip over the insulation to make a firm mechanical connection). Unscrew the cover of the banana plug and slip it over the other end of the wire. Insert this wire end in the terminal hole on the banana plug and solder. Slide the cover to the end of the plug and screw it tight.

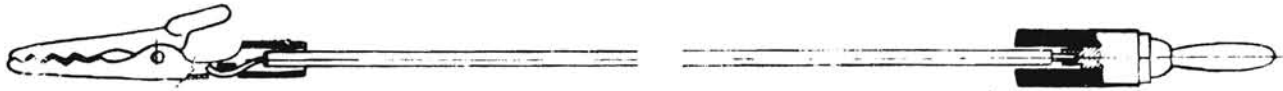
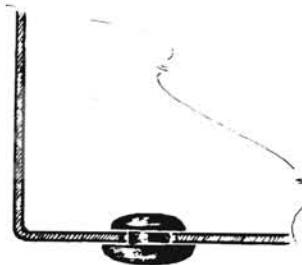

Fig.13

FINAL STEPS

You have now completed the assembly and wiring of your instrument. When you have completed the following steps your instrument will be ready for use.

- 1) Make a careful examination of the unit to determine whether all joints are soldered properly. Check for loose lumps of solder and straighten out the wiring and components so that there are no accidental shorts.
- 2) The flowing of rosin between switch contacts causes leakage. If examination reveals the presence of rosin, remove by briskly cleaning the area between the contacts with a stiff brush saturated with carbon tetrachloride. Be very careful! not to spring the contacts when cleaning switches.
- 3) Fig. 14. Insert the 12AU7 tube (V1) and the 6AL5 tube (V2) in their sockets and the battery in its holder.
- 4) Attach and align the knobs as follows:
 - a) Fasten pointer knobs to the FUNCTION and RANGE selector switches and turn them to the extreme counter-clockwise positions. Loosen the knob set screws. Line up the FUNCTION knob with the "OFF" position and the RANGE knob with the "1.5V" position, and retighten the set screws.
 - b) Fasten small round knobs to the ZERO ADJ. and OHMS ADJ. controls.
- 5) With the instrument disconnected from the line, check the resistances from the positive and negative sides of C5 to ground. The resistance from the positive side of C5 to ground should not be less than 25,000 ohms. The resistance from the negative side of C5 to ground should not be less than 50,000 ohms. If either resistance is less than the specified amount, recheck the circuit (B plus or B minus as required). Do not connect the instrument to the line until the trouble is remedied.



- 6) Install the rubber feet in the openings provided in the bottom of the cabinet as shown. The method is to work the rounded portion of each foot into the interior of the cabinet from the outside, using a small screw driver. The flat portion should be the actual resting or contact surface.

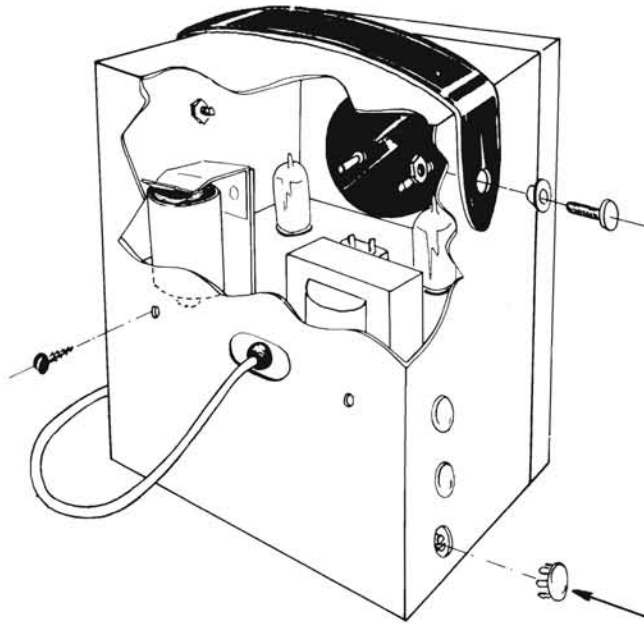

Fig. 14

7) Mount the leather handle on the cabinet using two brass eyelets, two #10-24 screws, and two #10-24 nuts. See Fig. 14 for a detailed drawing of the assembly.

8) Run the ac line cord through the rear cabinet opening and insert the completed unit in the cabinet, fitting the cabinet edges inside the lip around the panel. Use the line cord to position the chassis so that the two #6 holes in the rear chassis apron line up with the corresponding holes in the cabinet rear and insert two #6 P.K. screws. After the screws are tightened, chassis installation is completed.

9) Refer to the MAINTENANCE section of the Instruction Book and carry out the calibration procedure therein described. When the calibration is completed, insert the three buttons that cover the cabinet holes thru which the calibration controls are reached.

NOTE

If the instrument fails to operate properly, recheck the wiring for errors or reversed connections, test for continuity, and check individual components for breakdown. Check all dc and ac operating voltages, keeping in mind that all voltages may vary from the values shown by as much as 20% due to component tolerance, line voltage variations, and the type of measuring instrument used (schematic voltages were measured with VTVM).

SERVICE

If you are still having difficulty, write to our service department listing all possible indications that might be helpful. If desired, you may return the instrument to our factory where it will be placed in operating condition for \$6.00 plus the cost of parts replaced due to their being damaged in the course of construction. This service policy applies only to completed instruments constructed in accordance with the instructions as stated in the manual. Instruments that are not completed or instruments that are modified will not be accepted for repair. Instruments that show evidence of acid core solder or paste fluxes will be returned not repaired. **NOTE:** Before returning this unit, be sure all parts are securely mounted. Attach a tag to the instrument, giving your home address and the trouble with the unit. Pack very carefully in a rugged container, preferably wood, using sufficient packing material (cotton, shredded newspaper, or excelsior), to make the unit completely immovable within the container. The original shipping carton is satisfactory, providing the original inserts are used or sufficient packing material is inserted to keep the instrument immovable. Ship by prepaid Railway Express, if possible, to the Electronic Instrument Co., Inc. 33-00 Northern Blvd., L.I.C. 1, New York. Return shipment will be made by express collect. Note that a carrier cannot be held liable for damages in transit if packing, IN HIS OPINION, is insufficient.

CAPACITOR COLOR CODES

RMA 3-DOT COLOR CODE FOR MICA-DIELECTRIC CAPACITORS

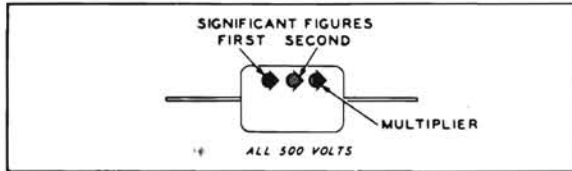

JAN 6-DOT COLOR CODE FOR PAPER-DIELECTRIC CAPACITORS

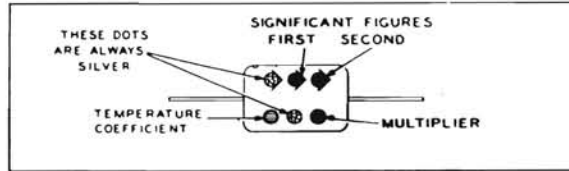

RMA 6-DOT COLOR CODE FOR MICA-DIELECTRIC CAPACITORS

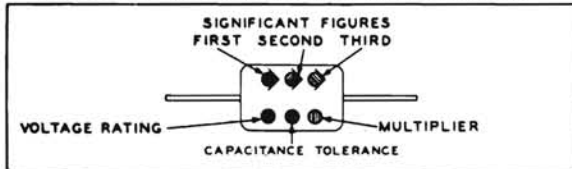

JAN 6-DOT COLOR CODE FOR MICA-DIELECTRIC CAPACITORS

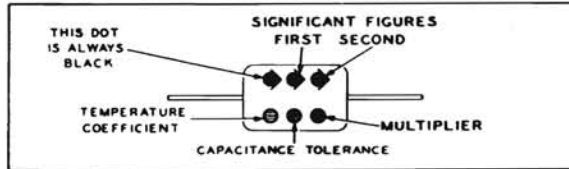

RMA COLOR CODE FOR TUBULAR CERAMIC-DIELECTRIC CAPACITORS

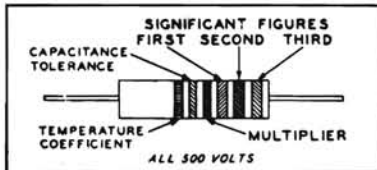

JAN COLOR CODE FOR FIXED CERAMIC-DIELECTRIC CAPACITORS

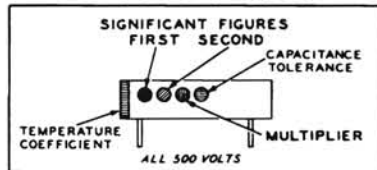

AXIAL TYPE INSULATED

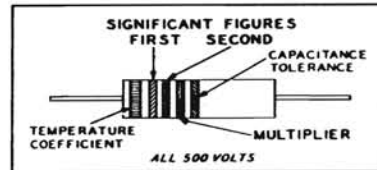

RMA: RADIO MANUFACTURERS ASSOCIATION
JAN: JOINT ARMY-NAVY

| RESISTORS | | | | CAPACITORS | | | | |
|-----------|------------|--------------------|----------|---------------------------------|-------------------------------|------------------------|----------------|-------------------------|
| TOLERANCE | MULTIPLIER | SIGNIFICANT FIGURE | COLOR | MULTIPLIER | | | VOLTAGE RATING | TEMPERATURE COEFFICIENT |
| | | | | RMA MICA AND CERAMIC-DIELECTRIC | JAN MICA AND PAPER-DIELECTRIC | JAN CERAMIC DIELECTRIC | | |
| | 1 | 0 | BLACK | 1 | 1 | 1 | | A |
| | 10 | 1 | BROWN | 10 | 10 | 10 | 100 | B |
| | 100 | 2 | RED | 100 | 100 | 100 | 200 | C |
| | 1000 | 3 | ORANGE | 1000 | 1000 | 1000 | 300 | D |
| | 10000 | 4 | YELLOW | 10000 | | | 400 | E |
| | 100000 | 5 | GREEN | 100000 | | | 500 | F |
| | 1000000 | 6 | BLUE | 1000000 | | | 600 | G |
| | 10000000 | 7 | VIOLET | 10000000 | | | 700 | |
| | 100000000 | 8 | GRAY | 100000000 | | 0.01 | 800 | |
| | 1000000000 | 9 | WHITE | 1000000000 | | 0.1 | 900 | |
| 5 | 0.1 | | GOLD | 0.1 | 0.1 | | 1000 | |
| 10 | 0.01 | | SILVER | 0.01 | 0.01 | | 2000 | |
| 20 | | | NO COLOR | | | | 500 | |

RESISTOR COLOR CODES

RMA COLOR CODE FOR FIXED COMPOSITION RESISTORS

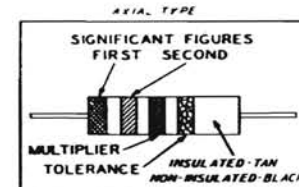

RADIAL TYPE

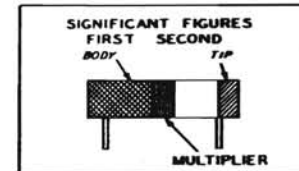

JAN COLOR CODE FOR FIXED COMPOSITION RESISTORS

AXIAL TYPE INSULATED

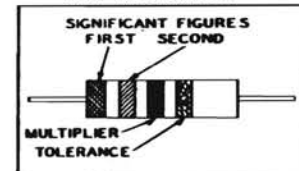

RADIAL TYPE NON-INSULATED

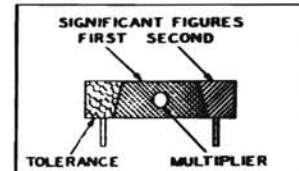

All switch wafer slides shown as they appear looking from the front (shaft end) of the switch toward the rear. The rear side of each wafer is seen looking thru the wafer from the front.

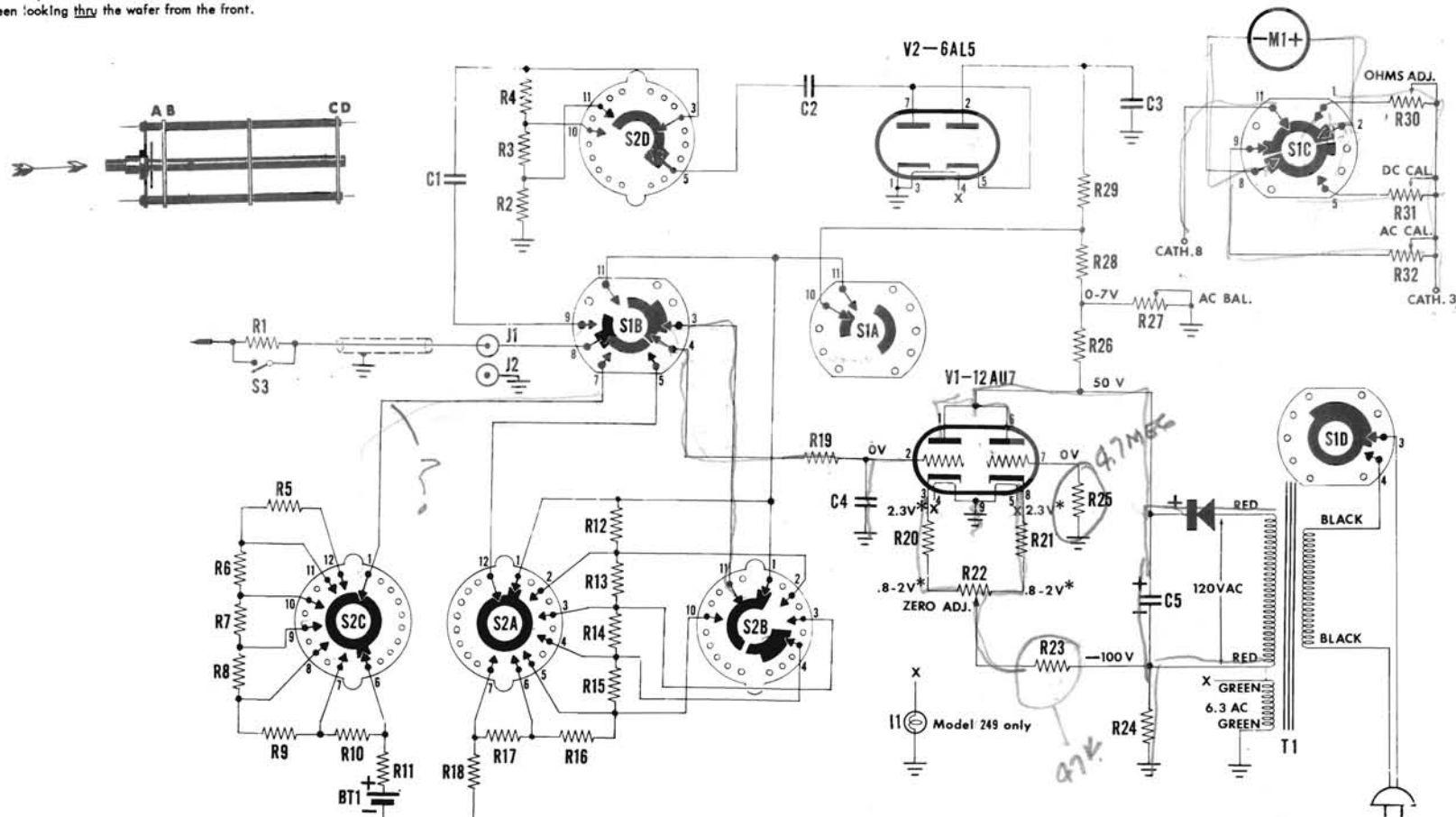

| Sym. | Description |
|--------|-----------------------|
| BT1 | battery, 1 1/2V |
| C1 | cap., .1mf - 1000V |
| C2, C3 | cap., .025mf - 400V |
| C4 | cap., .003mf - 400V |
| C5 | cap., elec. 10mf-150V |
| CR1 | rect., 35 ma |
| I1* | bulb, #47 |
| M1 | meter, 400ua |
| R1 | res., 1MΩ, 1/2W |
| R2 | res., 150KΩ, 1/2W, 1% |
| R3 | res., 325KΩ, 1/2W, 1% |

| Sym. | Description |
|------|-----------------------|
| R4 | res., 900KΩ, 1W, 1% |
| R5 | res., 9MΩ, 1/2W, 1% |
| R6 | res., 900KΩ, 1/2W, 1% |
| R7 | res., 90KΩ, 1/2W, 1% |
| R8 | res., 9KΩ, 1/2W, 1% |
| R9 | res., 900Ω, 1/2W, 1% |
| R10 | res., 90Ω, 1/2W, 1% |
| R11 | res., 9.7Ω, 1/2W, 1% |
| R12 | res., 7MΩ, 1W, 1% |
| R13 | res., 2MΩ, 1/2W, 1% |

| Sym. | Description |
|---------|-----------------------|
| R14 | res., 700KΩ, 1/2W, 1% |
| R15 | res., 200KΩ, 1/2W, 1% |
| R16 | res., 70KΩ, 1/2W, 1% |
| R17 | res., 20KΩ, 1/2W, 1% |
| R18 | res., 10KΩ, 1/2W, 1% |
| R19 | res., 3.3MΩ, 1/2W |
| R20, 21 | res., 680Ω, 1/2W |
| R22, 30 | pot., 2KΩ, linear |
| R23 | res., 47K, 1/2W |
| R24 | res., 68K, 1/2W |

| Sym. | Description |
|---------|--------------------|
| R25 | res., 4.7MΩ, 1/2W |
| R26 | res., 33K, 1/2W |
| R27 | pot., 10KΩ, linear |
| R28 | res., 82MΩ, 1/2W |
| R29 | res., 18MΩ, 1/2W |
| R31, 32 | pot., 2KΩ, linear |
| S1 | switch, function |
| S2 | switch, range |
| V1 | tube, 12AU7 |
| V2 | tube, 6AL5 |

Rotors on all switch wafers shown in extreme counter-clockwise position.

| FUNCTION SWITCH S1 | | RANGE SWITCH S2 | |
|--------------------|-----------|-----------------|----------------|
| Position | Setting | Position | Setting |
| 1 | OFF | 1 | 1.5V, R X 1 |
| 2 | AC VOLTS | 2 | 5V, R X 10 |
| 3 | -DC VOLTS | 3 | 15V, R X 100 |
| 4 | +DC VOLTS | 4 | 50V, R X 1000 |
| 5 | OHMS | 5 | 150V, R X 10K |
| | | 6 | 500V, R X 100K |
| | | 7 | 1500V, R X 1M |

MODELS 232 - 249

PEAK TO PEAK VTVMs

MODELS 232, 249 CONSTRUCTION ADDENDA

If the Range Switch S2 (Stk. #60024) in your kit has a ceramic rear wafer, you will find that the contacts on this wafer are slightly displaced from the positions shown in Figs. 4 & 5 of the construction. This displacement is not a defect, but comes about because the ceramic wafer has provision for a greater number of positions than the original phenolic wafer. The general positions of corresponding contacts on the ceramic wafer is the same as that on the original phenolic wafer used as the model in Figs. 4 & 5.

I.E. 1097 Electronic Inst. Co., Inc.

47K YELLOW PURPLE ORANGE

UNIPROBE CONSTRUCTION ADDENDA

The contact holder E5 now has an additional #8-32 threaded hole (see figure below). Its purpose is to receive a #8-32 x 3/16 set screw for securing the cable. The set screw should be inserted after the coaxial cable is inserted in E5 and the inner conductor soldered to the extension of contact K2. Locate this operation in the construction text and enter a note referring to this addenda. Add to the parts list the following entry:

| <u>Stock#</u> | <u>Sym.</u> | <u>Description</u> | <u>Qty.</u> |
|---------------|-------------|------------------------|-------------|
| 41061 | | #8-32 x 3/16 set screw | 1 |

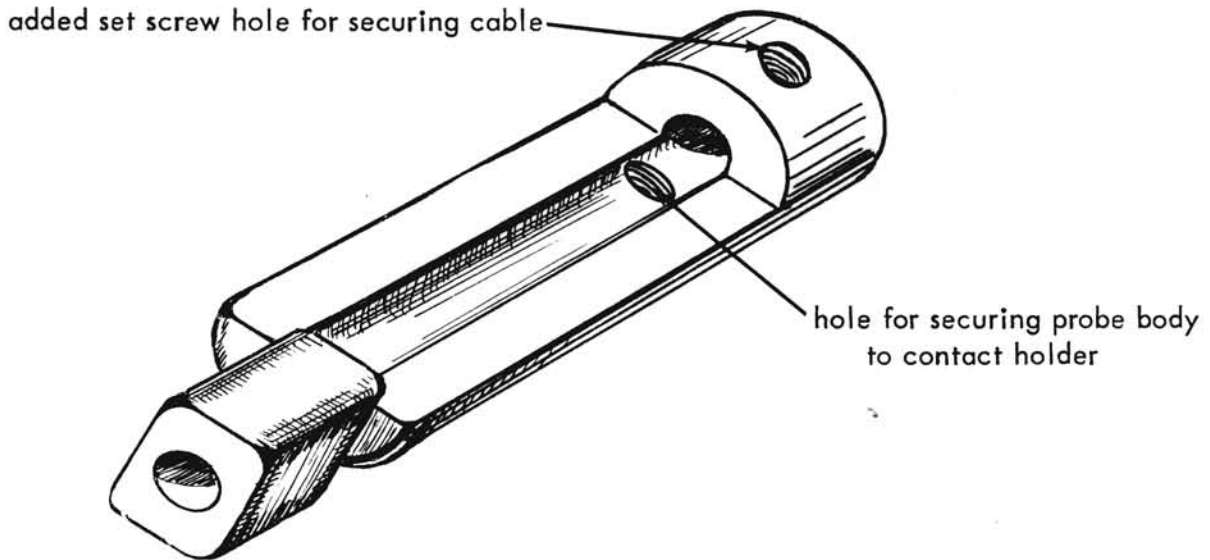

CONTACT HOLDER E5

NOTE: Do not confuse the added set screw hole for securing the cable with the hole for securing the probe body to the contact holder.

READING SCALES OF MODEL 232/249 VTVMS

All RMS scales are in black with full-scale values of 1.5, 5, 15, 50, 500, and 1500 volts. All peak-to-peak scales are in red with full-scale values of 4, 14, 42, 140, 420, 1400, and 4200 volts. For each RMS range marked on the RANGE switch dial, there is a black RMS scale and a corresponding red peak-to-peak scale. The correspondence is as follows:

| SELECTED RANGE | RMS VOLTAGE RANGE | BLACK SCALE USED | P-P VOLTAGE RANGE | RED SCALE USED | MULTIPLY SCALE READING BY (RMS/P-P) |
|----------------|-------------------|------------------|-------------------|----------------|-------------------------------------|
| 1.5 | 1.5 | LOW AC 1.5V | 4 | P-P 0-4 | 1 |
| 5 | 5 | DC RMS 0-5 | 14 | P-P 0-14 | 1 |
| 15 | 15 | DC RMS 0-15 | 42 | P-P 0-42 | 1 |
| 50 | 50 | DC RMS 0-5 | 140 | P-P 0-14 | 10 |
| 150 | 150 | DC RMS 0-15 | 420 | P-P 0-42 | 10 |
| 500 | 500 | DC RMS 0-5 | 1400 | P-P 0-14 | 100 |
| 1500 | 1500 | DC RMS 0-15 | 4200 | P-P 0-42 | 100 |

Note that the Model 232 responds to the peak-to-peak value of the a-c voltage waveform, not the RMS value. Therefore the reading on the red p-p scales is correct regardless of the shape of the waveform, while the reading on the black rms scales is correct only for sine waveforms. The black RMS scales have been calculated from the P-P scales, by multiplying each red p-p value of the correct ratio between the RMS and P-P values for sine waves only ($1/\sqrt{2}$, 0.707).

MODELS 232 - 249 ADDENDA

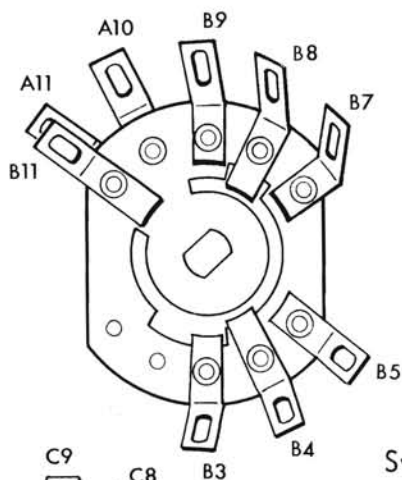

FRONT
WAFER

Switch #60025 in counter-clockwise position viewed from rear.

This switch replaced by Stock #60067.

REAR
WAFER

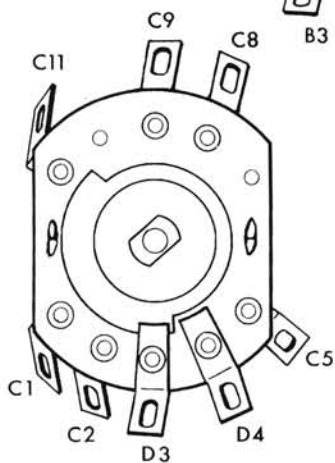

360

FRONT
WAFER

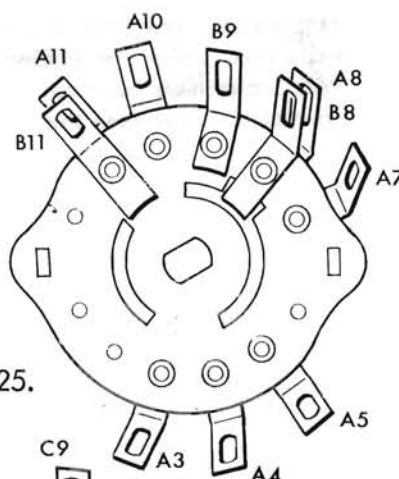

Switch #60067 in counter-clockwise position viewed from rear. This switch replaces #60025.

REAR
WAFER

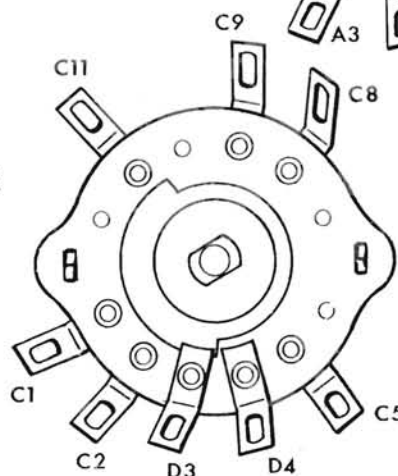

CROSS REFERENCE

| | |
|-------------------------|-------|
| 60025 Const. Book | 60067 |
| B7 | A7 |
| B8 | A8-B8 |
| B5 | A5 |
| B4 | A4 |
| B3 | A3 |

All other lugs the same

EICO

Service Policy

PARTS REPLACEMENT

If it appears that a component is defective, and you desire a replacement, contact your nearest EICO Authorized Service Agency or our Customer Service Department.

If you are claiming the right to a no-charge replacement under the terms and conditions of the warranty, it is required that you shall have sent in the registration card within 10 days of the date of purchase, and that you send back the defective part transportation prepaid. In claiming warranty service or parts, please send or show your **original sales slip** plus the IBM card from the carton. EICO or its authorized agency will make the necessary replacement at no charge for parts eligible under the terms and conditions of the warranty. In returning tubes, pack them very carefully to avoid breakage in shipment. Broken tubes will not be replaced. Please read the warranty on the subject of parts eligible for replacement.

Further information required on a part returned for a no-charge replacement under the terms and conditions of the warranty is as follows:

- a) Model number and serial number, if any, of unit. Also any code numbers in red under the words INSTRUCTION MANUAL on the cover of the book supplied with the unit.
- b) Stock number and description of part as given on the parts list. If the part is not listed (of itself) in the parts list, it means that the part is integral with a sub-assembly. If the sub-assembly is not sealed, and the defective part is definitely identified and easily replaceable (not more than two connections), you may request replacement for the particular part. If the sub-assembly is sealed, or if the defective part is not definitely identified or is not easily replaceable (more than two connections), then remove the sub-assembly and return it (less any tubes) for repair or replacement, if your unit is in warranty. If your unit is out of warranty, you are generally advised to order a replacement sub-assembly.
- c) Describe as completely as possible the nature of the defect, or reason for requiring replacement.

REPAIR SERVICE

EICO maintains a national network of authorized service agencies for in-warranty or out-of-warranty repair of EICO equipment. It is intended to serve those customers who are not sufficiently familiar with electronics to make use of the EICO Service Consultation facilities, or whose difficulties cannot be solved by correspondence.

For all out-of-warranty units, there is a minimum labor and handling fee. Charges for parts replaced are additional to the minimum fee.

For in-warranty completed kit units, there is a minimum labor and handling fee. There is no charge for a replaced defective part provided that the terms and conditions of the warranty for no charge replacement are not violated in the judgement of EICO.

For in-warranty factory-wired units, there is no charge for labor or parts if the unit complies with the terms and conditions of the warranty in the judgement

of EICO. However, if the terms and conditions of the warranty are violated there will be a charge for labor plus parts.

In all cases, the unit must be sent to the factory or service agency transportation prepaid, and the unit will be returned to the customer transportation collect.

On kits, the services rendered for the minimum labor and handling fee are the correction of any minor wiring errors (not extensive corrections or rewiring), the labor involved in replacing defective parts, and any adjustments, alignment, or calibration procedures that would normally be performed on a factory-wired unit. Units not wired according to instructions, or modified in any way, or showing evidence of the use of acid core solder, will not be serviced and will be returned to the customer forthwith.

SEE OUR SCHEDULE OF SERVICE CHARGES

Units requiring extensive corrections or rewiring will incur an additional labor charge. An advance estimate will be submitted.

Please note: minimum labor and handling fees and service charges are subject to revision at any time.

LOCAL REPAIR FACILITIES

A list of authorized service stations is provided with this manual. The roster of stations may change from time to time, and if considerable time has elapsed since you purchased your unit, you are advised to contact the station you choose before sending the unit to them for repair. Use of a local service station will often result in faster service, and, usually, lower transportation costs.

It is necessary that you comply with the Shipping Instructions that follow when sending in a unit for service.

SHIPPING INSTRUCTIONS

You are strongly advised to retain the original shipping carton and inserts should reshipment be required for service or any other purpose. The carton may be collapsed for storage in as small a space as possible. In very many cases, the same carton is used for kit and factory-wired units so that the kit carton will serve for reshipment of the completed kit.

When sending a unit for service pack the unit very carefully, preferably in the original shipping carton with the original inserts.

If this is not possible, use a strong oversize carton, preferably wood, and using at least 3 inches of resilient packing material such as shredded paper or excelsior inserted between all sides of the unit and the carton. Seal the carton with strong gummed paper tape or strong twine or both. Attach a tag to the instrument on which is printed your name and address and brief reference to the trouble experienced. Affix "FRAGILE" or "HANDLE WITH CARE" labels to at least four sides of the carton or print these words large and clear with a bright color crayon. Ship prepaid.

Include your name and address on the outside of the carton. Return shipment will be made transportation charges collect. Note that a carrier cannot be held liable for damage in transit, if packing, IN HIS OPINION, is insufficient.



THE EICO WARRANTY



The Electronic Instrument Company, Inc., hereafter referred to as EICO, warrants that, for a period of 90 days from the date of purchase, any EICO kit will be free of defects in parts, and that any EICO factory-wired unit will be free of defects in parts and workmanship. For an EICO kit, EICO's obligation is limited to those parts which are returned transportation prepaid to the factory or authorized service agency without further damage, and in the judgement of EICO are either originally defective or have become defective in normal use. EICO's obligation does not include any labor required to locate trouble in or repair a kit. For an EICO factory-wired unit, EICO's obligation is limited to replacement or repair, at EICO's option, of those parts, sections, or entire units returned transportation prepaid to the factory or authorized service agency without further damage, and in the judgement of EICO are either originally defective or have become defective in normal use.

The warranty does not apply to any parts damaged in the course of handling, assembling, or wiring by the customer, or damaged due to abnormal usage or in violation of instructions or reasonable practice, or further damaged to a consequential degree in return shipment. Furthermore, the foregoing warranty is made only to the original customer, and is and shall be in lieu of all other warranties, whether expressed or implied, and of all other obligations or liabilities on the part of EICO, and in no event shall EICO be liable for any anticipated profits, consequential damages, loss of time, or other losses incurred by the customer in connection with the purchase or operation of EICO products or components thereof.

The registration card, which accompanies each EICO kit or factory-wired unit, must be filled in and returned to the company within 10 days after the date of purchase. This warranty applies only to registered units.

SCHEDULE OF SERVICE CHARGES

- 1. Same prices for wired units or completed kits.
2. Charges are based on the schedule of minimum charges above. Some exceptions are noted below.
3. If the published rate is \$ 5.00-\$ 6.00, this covers up to 1 hour of labor time (minimum \$5.00).
If the published rate is \$ 6.50-\$ 8.00, this covers up to 1 1/2 hours.
If the published rate is \$ 9.00-\$10.00, this covers up to 2 hours.
If the published rate is \$11.00-\$14.50, this covers up to 2 1/2 hours.
If the published rate is \$15.00-\$20.00, this covers up to 3 1/2 hours.
4. Time required in excess of these minimum charges is calculated at \$5.00 per hour.
5. Above prices are for labor only. Parts are additional.
6. Miscellaneous prices not published in manuals are:
Probes - \$2.00 RP-100 Playback amp. only or
CRA & CRU - \$3.00 Power Supply only
or Record amp. only ...\$5.00
2536 Printed Circuit Board - \$5.00.
7 All prices are subject to change without notice.

MINIMUM LABOR AND HANDLING FEES

Table with 4 columns: Model Number, Labor Fee, Handling Fee, Total Fee. Lists various models like AF4, RA6, HF12, etc., with their respective charges.

* Model RP100 and Model 2400 will be billed on the basis of \$10.00 for the first hour and \$5.00 each additional hour, with a maximum unauthorized repair of \$50.00 for the kit and \$25.00 for a wired unit.

THIS KIT MUST BE PROPERLY SOLDERED!

USE ENOUGH HEAT

This is the main idea of good soldering. Apply enough heat to the metal surfaces you are joining to make the solder spread freely, until the contour (shape) of the connection shows under the solder.

AN ELECTRONIC UNIT WILL NOT WORK . . . unless it is properly soldered. Read these instructions carefully to understand the basic ideas of good soldering.

Enough heat must be used so the solder can actually penetrate the metal surfaces, making an unbroken path over which electricity can travel. You are not using enough heat if the solder barely melts and forms a rounded ball of rough, flaky solder.

Use the Right Soldering Tool

A soldering iron in the 40-100 watt range is recommended. Any iron in this range with a clean, chisel-shaped tip will supply the correct amount of heat to make a good solder connection. You may also use a solder gun but make sure the tip reaches full heat before you solder.

Keep the iron or gun tip brightly coated with solder. When necessary, wipe the hot tip clean with a cloth. If you are using an old tip, clean it before you start soldering. Use a fine file or steel wool to expose the bright metal. Heat the iron and immediately coat the tip with solder.

Use Only Rosin Core Solder

We supply the right kind of solder (*rosin core solder*). Do not use any other kind of solder! Use of Acid Core Solder, Paste, or Irons Cleaned on a Sal Ammoniac Block will ruin any Electronic Unit and will Void the Guarantee.

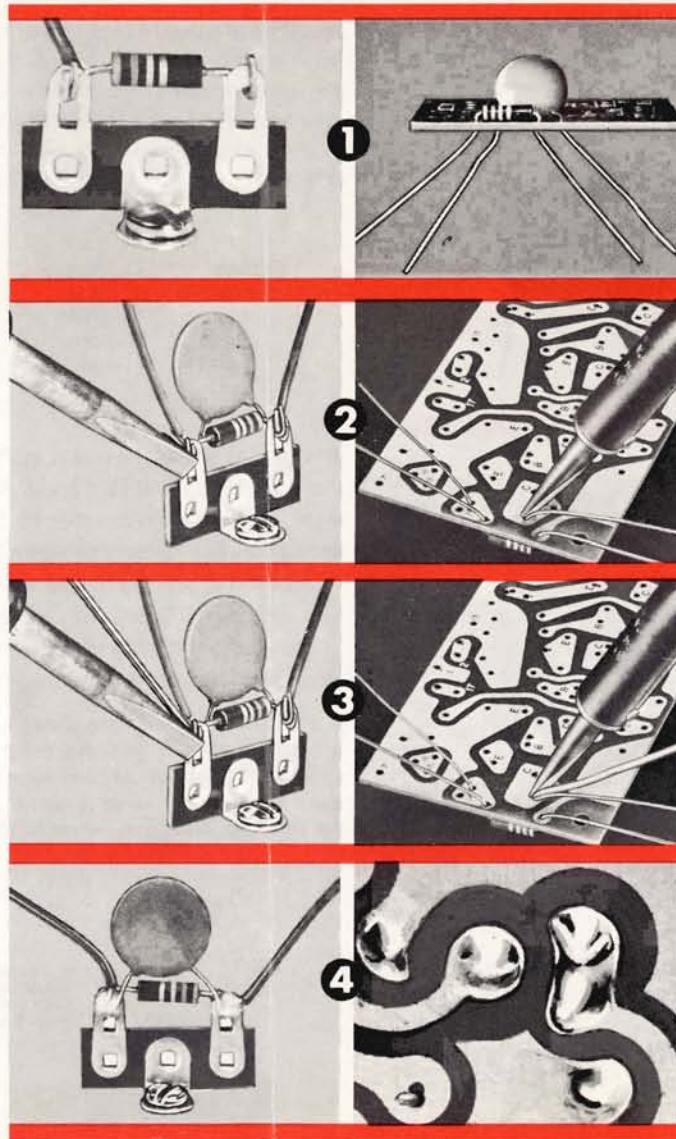

HERE'S HOW TO DO IT . . .

1. Join bare metal to bare metal; insulation must be removed. Make good mechanical connections and keep resistor and capacitor leads as short as possible, unless otherwise specified.

2. Coat the tip of a hot iron with solder. Then **Firmly Press the Flat Side of the Tip** against the parts to be soldered together. Count 3 out loud "One America, Two America, Three America." Do not remove the iron. **3.** Place the end of the solder between the metal to be soldered and the iron tip. Count "Four America, Five America." Remove the iron.

Use only enough solder to flow over all surfaces of the connection, and all wires in the connection.

Do Not Move Parts Until the Solder Hardens. If you accidentally move the wires as the solder is hardening, apply your iron and reheat.

4. Compare your soldering with the pictures on this page. You have a good connection if your solder has flowed over all surfaces to be connected, following the shape of the surfaces. It should appear smooth and bright and all wires in the connection should be well-soldered.

You Have Not Used Enough Heat: If your connection is rough and flaky-looking, or if the solder has formed a round ball instead of spreading.

The difference between good soldering (enough heat) and poor soldering (not enough heat) is just a few extra seconds with a hot iron firmly applied. **REMEMBER, LARGER METAL SURFACES TAKE A LONGER TIME TO HEAT.**

CAPACITORS and RESISTORS

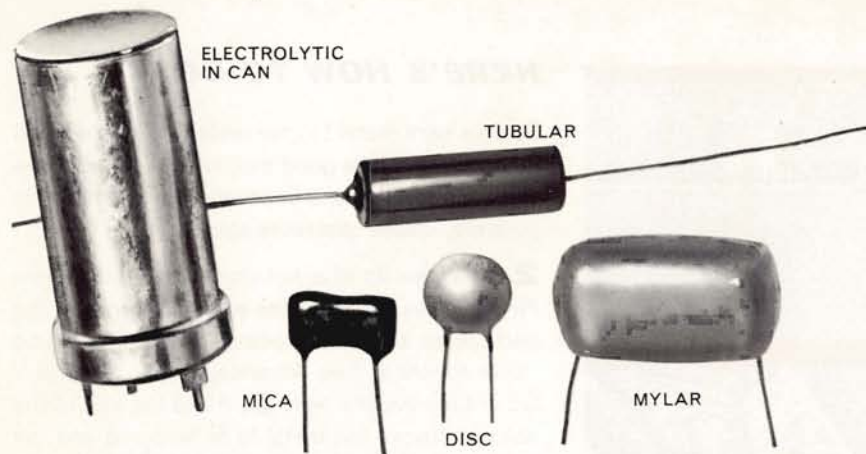

CAPACITOR IDENTIFICATION

The capacitors in your kit (named for their *capacity* for storing electrical energy) may be of several different types. You must choose the correct capacitor for each step, or the kit will not work as designed.

TYPE OR SHAPE. Select by type or shape such as disc, tubular, mylar, mica or electrolytic in a can.

CAPACITY VALUE. Select by capacity value, given in microfarads (μf or mf) or micro-microfarads ($\mu\mu\text{f}$, mmf or pf). Most small values are stated in micro-microfarads such as $10 \mu\mu\text{f}$ and $270 \mu\mu\text{f}$. Larger values are given in microfarads as $.02 \mu\text{f}$ and $.015 \mu\text{f}$.

On some disc capacitors, values may be stated either in μf or $\mu\mu\text{f}$. To change from μf to $\mu\mu\text{f}$, simply move the decimal point to the right 6 places. Here are a few examples of alternate markings:

.0022 μf equals 2200 $\mu\mu\text{f}$
 .01 μf equals 10,000 $\mu\mu\text{f}$
 .0033 μf equals 3300 $\mu\mu\text{f}$

VOLTAGE RATINGS. The capacitor may be marked with the maximum operating voltage, such as 600 v, 500 v, 350 vdc. Where these are important they will be stated.

TOLERANCE ratings are given in percentages (%). Where these are important they will be stated. Manufacturer's type number such as: SK, BIT, SPRAGUE, CRL, Z5F etc. are not used for identification purposes.

RESISTORS

Resistors are used to *resist* the flow of electricity. For your convenience, the resistors in your kit are supplied carded and labeled by R numbers for ready identification. Variable resistors (controls) and resistors too large to fit on the resistor card are clearly marked with the resistance value, either in ohms (Ω), thousand ohms (K) or million ohms (meg). The electronics color code used for the color bands on the resistors is easy to learn. Numbers 0 through 9 are shown by these colors:

| | |
|-------------|-------------|
| 0... black | 5... green |
| 1... brown | 6... blue |
| 2... red | 7... violet |
| 3... orange | 8... gray |
| 4... yellow | 9... white |

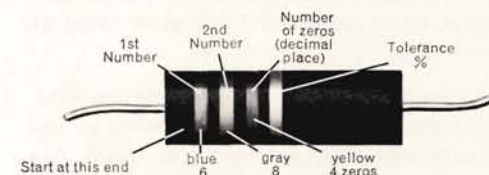

To read the value of a resistor, start at the end closest to the color bands. Write down the number for the *first band*, 6 (blue) in the example shown on this page. To the right of 6, write the number for the *second band*, 8 (gray) in our example. *The third band* gives the number of zeros. Since the third band in our example is yellow, write 4 zeros (0000) next to the 68, making the number 680,000 ohms. This is usually given in a short form, 680K, with K standing for a thousand ohms.

The fourth color band shows the tolerance rating, or how closely the resistance value is controlled in manufacture. Silver indicates a tolerance of $\pm 10\%$, gold, $\pm 5\%$.

SPECIAL CASE. For resistors under 10 ohms, the third color band will be silver or gold. If the third band is gold, the resistor is between 1 and 10 ohms so the decimal point goes between the first and second digit. For example, blue, gray, gold is 6.8 ohms. But if the third band is silver, the value is less than 1 ohm, with the decimal point before the first digit. For example, blue, gray, silver is .68 ohms.

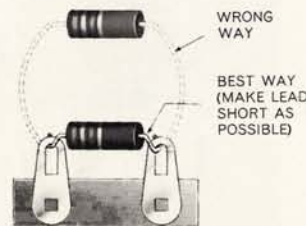

MOUNTING RESISTORS AND CAPACITORS

Keep resistor and capacitor leads **SHORT**. Mount the part as shown in the wiring illustrations... then pull the leads all the way through. Cut off excess lead length. Proper soldering techniques are shown on the other side.