

specifications

FOR THE

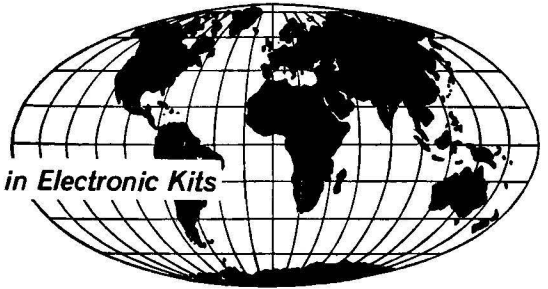

Pioneer And World-Leader in Electronic Kits



EXTERNAL LMO

MODEL SB-640



All prices are subject to change without notice. The Heath Company reserves the right to discontinue instruments and to change specifications at any time.

**HEATH COMPANY,
BENTON HARBOR,
MICHIGAN**

INTRODUCTION

The Heathkit External LMO (Linear Master Oscillator) is designed for use with the Heathkit Model SB-101 Transceiver. With this combination, you can transceive on this External LMO, on the internal LMO of the Transceiver, or on either of two crystal frequencies. You can also receive on the Transceiver's LMO and transmit on the external LMO. All of these functions are switch-selected from the front panels of the instruments.

To SB-101 Transceiver owners, the SB-640 provides wide versatility for working DX stations in a different sub-band, or for the customary procedure of calling 5 or 10 kHz up or down from the DX station's frequency. You can work a net by transceiving on a crystal frequency, by using both LMOs, or by transmitting crystal controlled and receiving on LMO.

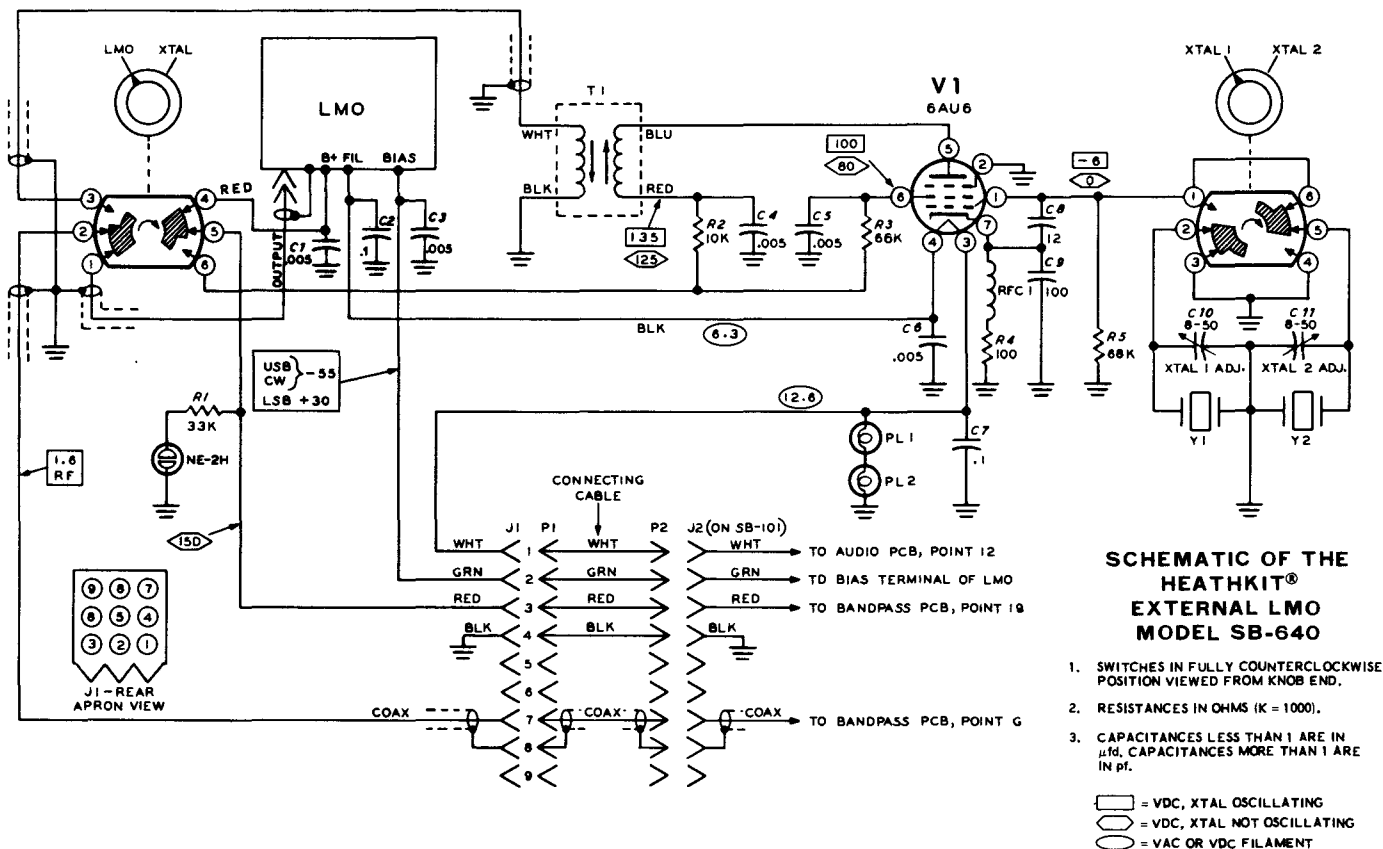

SPECIFICATIONS

Frequency Output, LMO.	5 to 5.5 MHz.
Frequency Output, Crystal.	4.975 to 5.525 MHz.
Frequency Stability*.	Less than 100 Hz per hour after 20 minutes warmup from normal ambient conditions. Less than 100 Hz for $\pm 10\%$ line voltage variations.
Visual Dial Accuracy*.	Within 200 Hz on all bands.
Electrical Dial Accuracy*.	Within 400 Hz after calibration at nearest 100 kHz point.
Dial Mechanism Backlash*.	Less than 50 Hz.
Front Panel Controls.	Main (LMO) Tuning dial, LMO/XTAL switch, Crystal Selector switch-XTAL 1/XTAL 2.
Panel Light.	ON when transmitting or transceiving frequency is controlled by External LMO.
Rear Apron Facilities.	Connector to SB-101, Frequency Adjust trimmers XTAL 1 and XTAL 2.
Power Requirements (from SB-101 Transceiver).	150 VDC at 5 ma, 12.6 VAC at 450 ma.
Cabinet Dimensions.	6-5/8" high (plus feet) x 10" wide x 11-3/8" deep (including knobs).
Net Weight.	5-1/4 lbs.

*Identical to the same specification in the SB-101 Transceiver.

FREQUENCY CONSIDERATIONS

The DRIVER PRESELECTOR tunes the same circuits for both transmit and receive. Therefore, when you operate with the Transceiver **FREQ CONTROL** switch in the **UNLOCKED AUX** position, it is recommended that the Transceiver be tuned for "peak" output using the External LMO to determine the transmitting frequency. Then the Transceiver LMO will select the receiving frequency.

signal. Maximum permissible deviation is governed by the strength of the received signal; if the signal is strong enough, it will overcome the losses.

The following table shows how many kHz above or below the "peaked" transmitting frequency you can receive in the **UNLOCKED AUX** position before you have a loss of 3 db in the received

<u>BAND</u> <u>(MHz)</u>	<u>kHz BELOW</u> <u>PEAK</u>	<u>kHz ABOVE</u> <u>PEAK</u>
3.5	15	50
7	20	100
14	50	200
21	100	300
28-29.5	200	400