



www.DaltonsWadkin.com

Station Road  
Sowerby Bridge  
West Yorkshire  
HX6 3LA  
England

Tel: 0422 831861  
Fax: 0422 839785  
Telex: 517400

OPERATING & MAINTENANCE INSTRUCTIONS

MAKE: BROOKMAN

MODEL: SELF FEED DRILL.

TEST NO: \_\_\_\_\_

ALL ENQUIRIES FOR SPARES, TOOLING, SERVICE AND  
TECHNICAL ADVICE SHOULD BE FORWARDED TO ONE OF THE  
PERSONNEL LISTED BELOW:

K WRIGHT - SALES DIRECTOR  
I SPENCER - SPARES, TOOLING & SERVICE  
A MOTTRAM - TECHNICAL ADVICE

*Specialists in Woodworking Machinery*

Directors: J. B. Morris, S. M. Morris, K. D. Wright. Registered Number 2648776 England.

www.DaltonsWadkin.com

### SAFETY RULES

THE SAFE OPERATION OF WOODWORKING MACHINERY REQUIRES CONSTANT ALERTNESS AND CLOSE ATTENTION TO THE WORK IN HAND.

CAREFULLY READ INSTRUCTION MANUAL BEFORE OPERATING MACHINE.

DO NOT OPERATE WITHOUT ALL GUARDS AND COVERS IN POSITION.

BE SURE MACHINE IS ELECTRICALLY EARTHED - GROUNDED.

REMOVE OR FASTEN LOOSE ARTICLES OF CLOTHING SUCH AS NECKTIES, ETC. CONFINE LONG HAIR.

REMOVE JEWELLERY SUCH AS FINGER RINGS, WATCHES, BRACELETS, ETC.

USE SAFETY FACE SHIELD, GOGGLES OR GLASSES TO PROTECT EYES AND OTHER PERSONAL SAFETY EQUIPMENT AS REQUIRED.

STOP MACHINE BEFORE MAKING ADJUSTMENTS OR CLEANING CHIPS FROM WORK AREA.

BLUNT CUTTERS OFTEN CONTRIBUTE TO ACCIDENTS. AN EFFICIENT MACHINIST KNOWS WHEN RE-SHARPENING IS NECESSARY, BUT IF THERE IS RELUCTANCE TO SPEND TIME ON GRINDING AND RE-SETTING, THE CUTTERS MAYBE RUN BEYOND THEIR EFFICIENT LIMITS AND, INSTEAD OF CUTTING EFFICIENTLY AND SMOOTHLY, THEY TEND TO CHOP AND SNATCH AT THE WOOD. THIS NOT ONLY INCREASES THE RISK OF ACCIDENTS, BUT ALSO LOWERS THE QUALITY OF THE WORK.

CUSTOMERS ARE STRONGLY ADVISED TO USE, AT ALL TIMES, HIGH TENSILE STRENGTH CUTTER BLOCK BOLTS WHICH SHOULD BE TENSIONED BY MEANS OF A TORQUE SPANNER.

KEEP THE FLOOR AROUND THE MACHINE CLEAN AND FREE FROM SCRAPS, SAWDUST, OIL OR GREASE TO MINIMISE THE DANGER OF SLIPPING.

THIS MACHINE, WHEN UNDER WORKING CONDITIONS, MAY PRODUCE A NOISE LEVEL IN EXCESS OF 90 D.B. CALDER WILKINSON LTD. WILL SUPPLY INFORMATION ON ACOUSTICAL ENCLOSURES ON REQUEST, AND WILL REQUIRE A WRITTEN UNDERTAKING THAT THE NECESSARY STEPS WILL BE TAKEN TO ENSURE THAT THE MACHINE IS ONLY USED IN COMPLIANCE WITH THE TERMS OF HEALTH AND SAFETY AT WORK-ACT 1974.

## HEALTH AND SAFETY ADVICE

This machine is designed and constructed to the principles of safeguarding and practical guidance contained in the British Standard Codes of Practice BS 5304:1988 "safety of machinery", BS6854:1987 "Safeguarding woodworking machines" and current guidance issued by the Health and Safety Executive.

The Health and Safety at Work etc. Act 1974 places duties on designers, manufacturers and suppliers to ensure that:

- i articles supplied for use are, so far as is reasonably practicable, safe and without risk to health during setting, use, cleaning and maintenance and
- ii persons supplied with the articles are provided with adequate information about the use for which they are designed and about conditions necessary to ensure that they will be safe and without risks to health.

These duties are transferred to you if you re-supply the machine by way of sale, lease, hire or hire-purchase.

Persons who install this machine for use at work have a duty under The Health and Safety at Work etc. Act 1974 to ensure, so far as is reasonably practicable, that nothing about the way in which it is installed makes it unsafe or a risk to health. This includes such aspects as correct assembly, electrical installation, construction of enclosures, fitting of guards and exhaust ventilating equipment. When installing this machine, consideration must be given to the provision of adequate lighting and working space.

This machine is supplied complete with all necessary safeguards to enable the user to comply with the Woodworking Machines Regulations 1974. Details of correct installation and use, together with guidance on fitting and proper adjustment of guards are described in this manual.

The woodworking Machines Regulations place absolute legal duty on employers and employees to ensure that guards and any other safety devices are securely fitted, correctly adjusted and properly maintained.

Repairs and maintenance must only be undertaken by competent technicians. Ensure that all power supplies are isolated before maintenance work commences. Instructions for routine maintenance are included in this manual.

Machine operators must have received sufficient training and instructions as to the dangers arising in connection with the machine, the precautions to be observed and the requirements of the Woodworking Machines Regulations which apply, except where they work under the adequate supervision of a person who has a thorough knowledge and experience of the machine and the required safeguards.

Persons under the age of eighteen years must have successfully completed an approved course of training before operating this machine at work, unless participating in a course of training under adequate supervision. (NB. This paragraph is only relevant to: circular sawing machines, any sawing machines fitted with a circular blade, any planing machine for surfacing which is not mechanically fed or any vertical spindle moulding machine).

Before commencing work, ensure that the tooling is set to cut in the correct direction, securely fastened, sharp and is compatible with the machine and spindle speed.

### DUST

Wood dust can be harmful to health by inhalation and skin contact and concentrations of small dust particles in the air can form an explosive mixture. These concentrations usually occur in dust extraction equipment which may be destroyed unless explosion precautions have been taken in the design and installation of the equipment.

Employers have duties under the Factories Act 1961, the Health and Safety at Work etc. Act 1974 and the Control of Substances Hazardous to Health Regulations 1988 to control wood dust in the work-place.

Employers should carry out an adequate assessment of the possible risks to health associated with wood dust to enable a valid decision to be made about the measures necessary to control the dust. It may be necessary to provide effective exhaust appliances.

Prevention or control of wood dust exposure should, so far as is reasonably practicable, be achieved by measure OTHER than the provision of personal protective equipment.

Further information and references to practical guidance are contained in free leaflets available from the Health and Safety Executive.

### NOISE

Noise levels can vary widely from machine to machine depending on conditions of use. Persons exposed to high noise levels, even for a short time, may experience temporary partial hearing loss and continuous exposure to high levels can result in permanent hearing damage. The Woodworking Machines Regulations require employers to take reasonably practicable measures to reduce noise levels where any person is likely to be exposed to a continuous equivalent noise level of

90 Db(A) or more over an 8 hour working day. Additionally, suitable ear protectors must be provided, maintained and worn.

Machines identified as generating unhealthy noise levels should be appropriately marked with a warning of the need to wear hearing protection and it may be necessary to designate particular areas of the work-place as "Ear protection zones". Suitable warning signs are specified in the Safety Signs Regulations 1980. It may be necessary to construct a suitable noise enclosure, in which case professional advice should be sought.

Further information and references to practical guidance are contained in free leaflets available from the Health and Safety Executive, and specifically in "The noise at work regulations 1989" - 1989 No. 1790

The measured noise level for this machine when working under normal conditions is                      dB(A).

www.DaltonsWadkin.com

**GENERAL DATA**

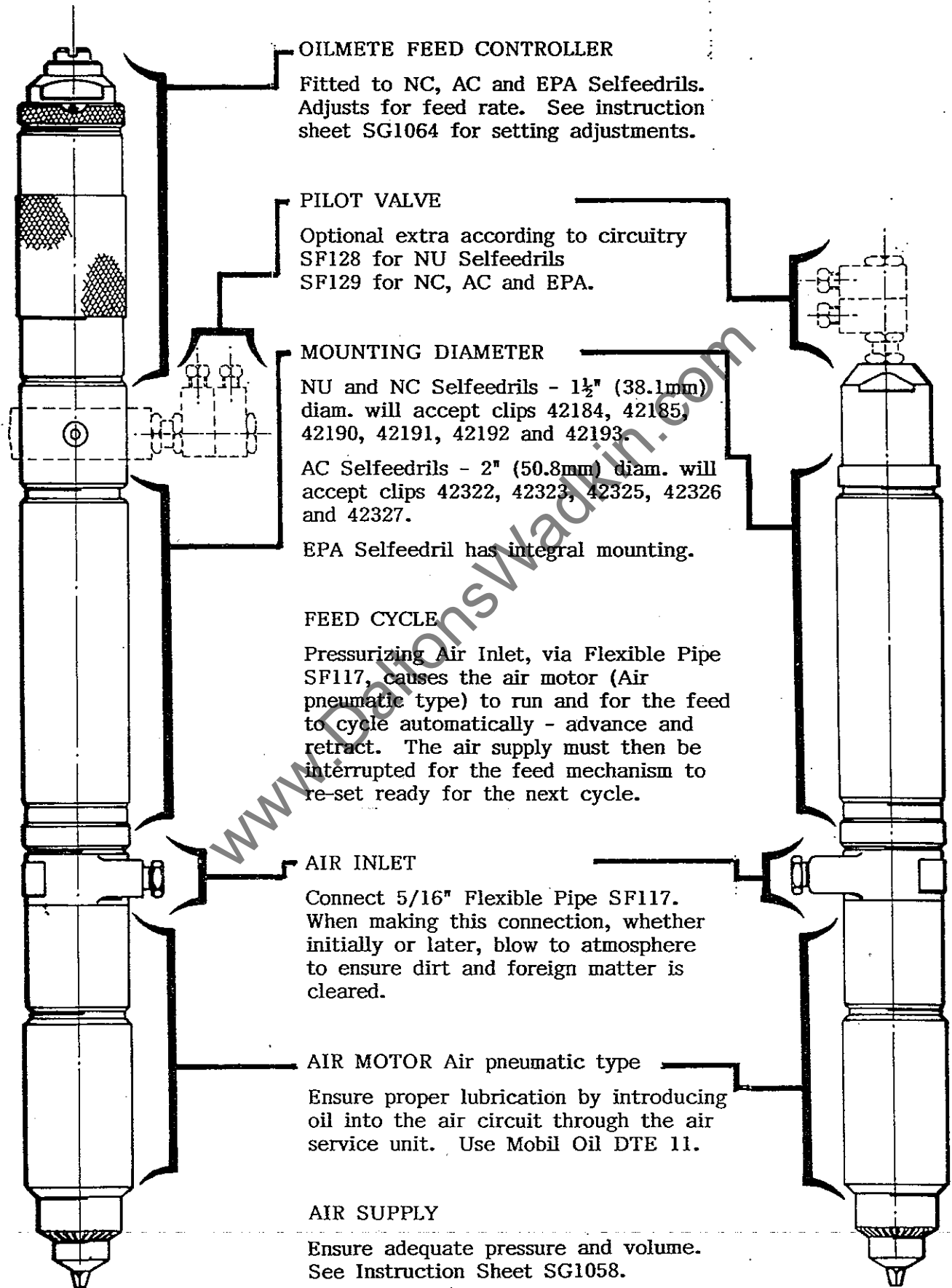

**OILMETE FEED CONTROLLER**

Fitted to NC, AC and EPA Selfedrils. Adjusts for feed rate. See instruction sheet SG1064 for setting adjustments.

**PILOT VALVE**

Optional extra according to circuitry SF128 for NU Selfedrils SF129 for NC, AC and EPA.

**MOUNTING DIAMETER**

NU and NC Selfedrils - 1½" (38.1mm) diam. will accept clips 42184, 42185, 42190, 42191, 42192 and 42193.  
 AC Selfedrils - 2" (50.8mm) diam. will accept clips 42322, 42323, 42325, 42326 and 42327.  
 EPA Selfedril has integral mounting.

**FEED CYCLE**

Pressurizing Air Inlet, via Flexible Pipe SF117, causes the air motor (Air pneumatic type) to run and for the feed to cycle automatically - advance and retract. The air supply must then be interrupted for the feed mechanism to re-set ready for the next cycle.

**AIR INLET**

Connect 5/16" Flexible Pipe SF117. When making this connection, whether initially or later, blow to atmosphere to ensure dirt and foreign matter is cleared.

**AIR MOTOR Air pneumatic type**

Ensure proper lubrication by introducing oil into the air circuit through the air service unit. Use Mobil Oil DTE 11.

**AIR SUPPLY**

Ensure adequate pressure and volume. See Instruction Sheet SG1058.

**COMPRESSED AIR REQUIREMENT**

- 1 Selfedrills require connection to a compressed air supply. The following information relates, primarily, to Air-pneumatic Selfedrills, ie those having air motor drive to the drill spindle. The air consumption of Air-electric Selfedrills is very low, by comparison, hence the air provision will not be so exacting, although the need to maintain pressure will be as important.
- 2 The designed maximum operating pressure is 100 lbs psi - 6.9 bar which should not be exceeded. The minimum acceptable pressure is 80 lbs psi - 5.5 bar. Efficiency and performance are directly related to pressure hence those nearing 100 lbs psi are preferable.
- 3 The volume of air required depends upon the number of Selfedrills, the rating of the motors, and the proportion of running to down time. The compressor capacity must be equal to the *consumption* rate, the air mains and piping must be of a size to accommodate the *demand* rate.
- 4 The motor ratings are:
 

P type	9 cfm	250 lm
R type	16 cfm	450 lm
S type	25 cfm	720 lm

The running to down time proportions vary according to the drilling application and should be examined accordingly, but assuming 50/50, which is common, the following examples can be given:

Number of Selfedrills - say 4

P type motors, rating 9 cfm hence

$$\text{Demand rate } 4 \times 9 = 36 \text{ cfm}$$

$$\text{Consumption rate } 4 \times 4\frac{1}{2} = 18 \text{ cfm}$$

Thus the air mains must be capable of passing 36 cfm; the compressor must be capable of sustaining 18 cfm.

- 5 The volume of air which can be passed by a pipe is governed by:
  - The pipe bore
  - The pipe length
  - Number of bends and elbows involved

The following table indicates the pipe sizes which must be considered according to the air demand rate. They assume a pipe run of reasonable length and not too many changes of direction by elbows. (Nominal pressure 100 lbs psi). Compressed air installation specialists should be consulted in cases of doubt.

**English**

Cubic feet of free air per minute	50	100	200
Minimum internal diameter of pipe (ins)	1	1½	2
Recommended internal diameter of pipe (ins)	1½	2	2¾

**Metric**

Litres of free air per minute	1400	2800	5600
Minimum internal diameter of pipe (mm)	25	40	50
Recommended internal diameter of pipe (mm)	40	50	70

- 6 An adequate air supply requires an efficient fundamental installation. If in doubt the services of a competent compressed air installer should be engaged. The sketch below indicates the type of factors which need to be observed when installing a compressed air system.

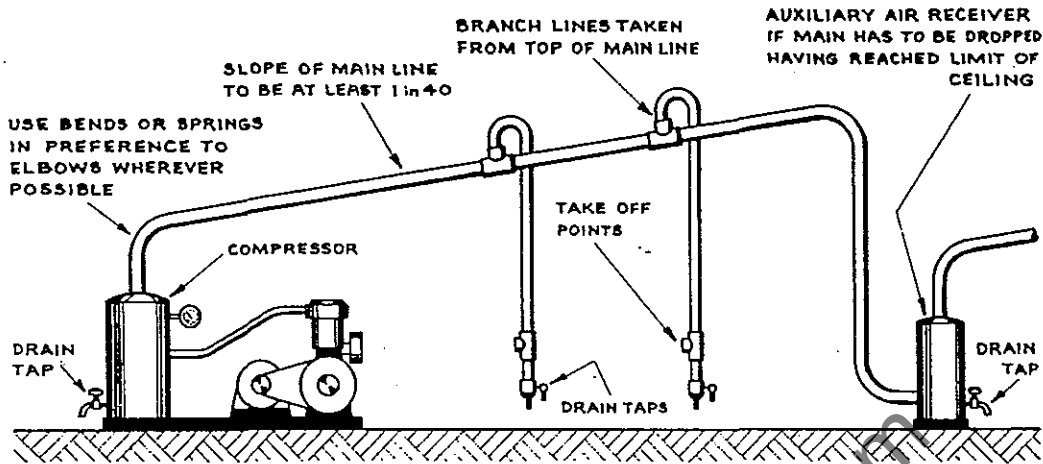

- 7 The original offer for the Selfedril installation will have specified the Demand and Consumption rates involved. If there is any doubt, or a need to re-calculate, see para 4 above and/or Guide Sheet E Leaflet SL45.



## INSTALLATION &amp; OPERATING

## 1 INTRODUCTION

- 1.1 Selfedrils are a unit drilling system, which system can be considered in three sections
- 1.1.1 The Selfedrill unit heads, which sub divide into
- Air-pneumatic type
- a) Airmete control version NU  
b) Oilmete control version NC and AC
- Air-electric type - EPA
- 1.1.2 The supporting components - Easi-rig.
- 1.1.3 The air distribution arrangement.
- 1.2 All Selfedrils use the basic self feeding mechanism, which is pneumatic, and primarily these notes are directed at ensuring the proper functioning of the pneumatic element.
- 1.3 As stated, the System is based on a unit (modular) build up. In many cases "an already assembled" structure will have been purchased, in which case the correct air distribution manifold, together with control valves, will have been provided. The user then need only to be concerned with mounting on a suitable bench (if the structure is not free standing) and connecting to an adequate compressed air supply.
- 1.4 In cases when individual items have been purchased with the intention of self assembly, the need arises to ensure that an efficient air distribution manifold is prepared.

## 2 OPERATION

- 2.1 To cause the Selfedrill to function compressed air is introduced via the Flexible Pipe SF117, into the Air Inlet. The Air Motor will start up, feed forward 57mm - 2 $\frac{1}{4}$ ins, and retract with the air motor still running. When fully retracted the compressed air must be shut off - by releasing the foot valve or whatever control valve is being used. This stops the air motor and also enables the feed mechanism to reset for the next operation. The Selfedrill will not re-cycle until the air supply has been interrupted.
- 2.2 When Work Clamp SF115 is used, this is supplied from the same air manifold as the Selfedrills. As the foot valve is depressed the clamps will immediately close onto the workpiece, and will remain so notwithstanding the Selfedrill has retracted, until the foot valve is released.

### 3 FEED CONTROL

#### 3.1 Selffeedrils are in two types:

Airmete control  
Oilmete control

3.2 The Airmete are not adjustable. An internal calibrated orifice meters the air flow into the piston chamber, thereby steadying the forward feed.

3.3 The Oilmete have the addition of an adjustable feed controller which is mounted as an extension, axially aligned. Full information on the controller is given in Instruction Sheet SG1064. The essential factor is that the forward feed is governed by an oil dashpot. The rate of feed can be varied by turning the outer knurled sleeve of the controller.

### 4 FEED STROKE

4.1 The Feed Stroke is fixed at 57mm 2¼ins. To adjust the depth of drilling the Selffeedril should be positioned axially in its mounting clip.

4.2 The depth of drilling resulting from a setting will be the clearance from drill point to workpiece face, subtracted from the full stroke. For example, if the distance from the drill point to the workpiece face is 32mm (1¼ins) the drill will penetrate to a depth of 25mm (1ins).

4.3 Flange mounting Preset PMH6, and Air-electric Selffeedrils EPA, may be provided with Depth Adjuster Screws. To adjust - the clamp holding the Feed Barrel is released and the adjustment is made by turning the knurled knob.

### 5 EASI-RIG MOUNTING COMPONENTS

5.1 For Standard Structures and arrangements supplied ready assembled, the selection of Easi-rig components will have already been decided. Decisions as to which Easi-rig components to select for self assembly should be made by consulting the relevant catalogue sheets.

5.2 Easi-rig clips and brackets are clamped in their working positions by socket head cap screws. To reposition the cap screw should be unscrewed using a 7/32" a/f hexagon wrench. Selffeedrils are very frequently secured to Bar 13348 by the Key Clamp Bracket 42915 or 6. These have Bristol clamping handles for quick re-positioning.

### 6 AIR DISTRIBUTION

6.1 For Standard Structures and arrangements supplied ready assembled, a suitable air distribution manifold will have been provided. In these cases all that is required is connection to an adequate compressed air supply. This implies adequate volume at a pressure between 80lbs and 100lbs psi - 5.5 to 6.9 bar. The Selffeedril will not function if the maximum is exceeded, whilst pressures below the minimum will impair performance.

- 6.2 When constructing an air distribution manifold, or modifying one which exists, the following precepts should be kept in mind. An even distribution of the compressed air is essential, to which end the manifold layout should follow a "trunk - branch - twig" development. It is important that the sum of the take off capacity does not exceed the capacity of the preceding pipe. The following diagrams illustrates the classic arrangement. The air main A delivers to the take off B. A has a nominal capacity of 12, whilst the take off B requires only 9. The latter divides into two branches C each of 4 capacity ( $4 + 4$  is less than 9). Each branch divides into three "twigs" of single rating, thus  $(1 \times 3) \times 2 = 6 < 4 \times 2 = 8$ .

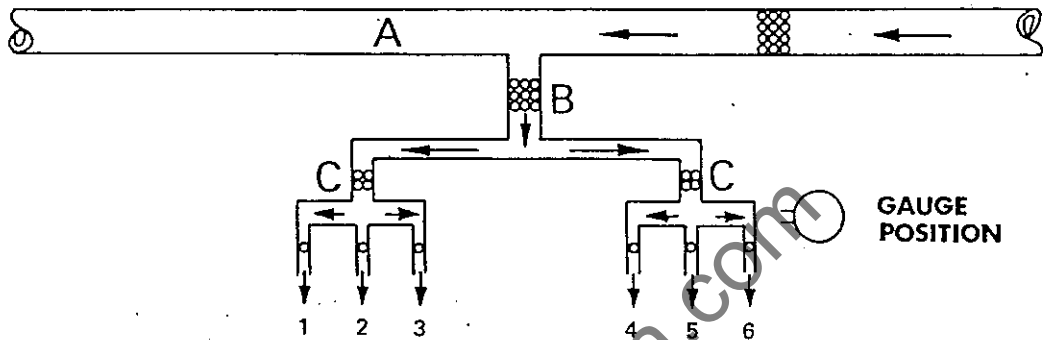

- 6.3 The second diagram illustrates the faults to be avoided. The primary take off which has a 5 capacity is inadequate to run the six "twigs", moreover it reduces to 4 before delivering. Additionally the air passes through a tap which is of less capacity than the pipe, and through a lubricator of insufficient size.

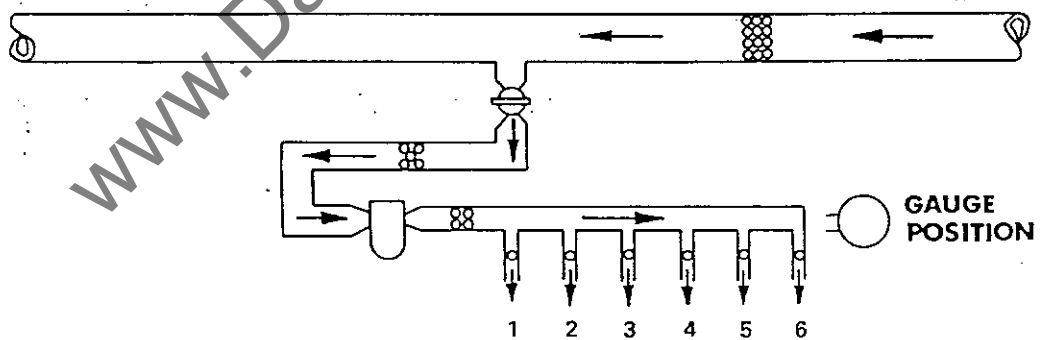

An important error to avoid, is air delivery from one end. The distribution shown in the diagram would result in outlets Nos 5 and 6 receiving no air, whilst Nos 3 and 4 would be below minimum. Compare with the "trunk, branch, twig" distribution shown in the previous diagram.

## 7 LUBRICATION

- 7.1 Lubrication of Selffeedrils is effected by introducing oil into the compressed air supply. Care should be taken to ensure the lubricant used is of a type prepared by reputable oil blenders, specifically for this purpose. Some oils, when atomised through oil mist systems, acquire explosive tendencies, hence their use must be avoided.
- 7.2 Most of the reputable oil blenders offer oil expressly designed for use in pneumatic circuits, and one of these should be used. The oil is required to provide lubrication to the rotating parts and gearing in the air motor, to the sliding parts in the feed mechanism, and to spools in air valves. The lubricant is introduced via the air line, and needs readily to atomize into oil mist.
- 7.3 The recommended oil is Mobil DTE 11.
- 7.4 The arrangement should be provided with an air service unit, which is introduced into the air circuit immediately after the mains connecting point. It should be preceded by a shut off tap to isolate the circuit from the air mains.
- 7.5 The unit comprises two chambers both of which have sight gauge glasses. The first is a water separator, which is self functioning. It will require draining, preferably daily, by turning the tap at the bottom. The accumulating water can be seen in the sight gauge.
- 7.6 The second chamber is the lubricator. This must be kept charged with pneumatic oil (Mobil DTE 11 is recommended) to the level indicated by the external gauge glass. It has two knobs, one is the cap to the filler. The other, which surmounts a sight glass, sets the rate of lubrication. The oil mist to be introduced into the pneumatic system by the lubricator can be seen functioning in the sight glass.
- 7.7 The lubrication rate will have been factory set, according to the installation and ordinarily will not require attention. It is important to ensure adequate and effective lubrication, but equally it is important not to over lubricate. An excess of oil will cause the various operating valves to malfunction.

## 8 MAINTENANCE

- 8.1 Data Sheet SG1066 gives a sectional diagram of the Selffeedril and itemises the individual components.
- 8.2 Provided the Selffeedril is kept supplied with clean air properly lubricated, the Selffeedril will require little maintenance. Over long periods the piston washer Item 37 will require replacement, and the Filter Item 14 may need replacing. 'O' Rings in the Feed Controller, fitted to NC and AC models will require replacement in time.
- 8.3 The vanes in the air motor will wear in time. Loss of air motor power indicates the vanes require replacement, but a check should be made that the air pressure is holding up before it is assumed vane wear is causing power loss.

8.4 Brookman operate an overhaul service. If the user decides to dismantle a Selfeedril it is important not to damage the components. Do not grip in a vice; secure the unit in a suitable Easi-rig clip, and then grip the clip in the vice.

8.5 A separate publication details dismantling procedure.

## 9 AIR-ELECTRIC SELFEE DRILLS

9.1 The feed mechanism used in the Air-electric Selfeedril is exactly the same as used for the Air-pneumatic, accordingly the foregoing instructions apply. The exception is that the air motor is omitted, the separately mounted chuck spindle being driven from an electric motor by a toothed belt.

9.2 Because the air motor is omitted, the compressed air consumption is considerably reduced. Calculations can be made on the basis of 1 cfm per head per operation.

9.3 Detailed information relating to the Air-electric Selfeedril is given in leaflet SG1063. The important factor to observe is that an electric power connection is required, and this must be undertaken by a competent electrician.

## 10 WORKPIECE HOLDING CLAMPS

10.1 Work Clamps SF115 are connected into the same air manifold as that serving the Selfeedrils. They will then function in unison with the Selfeedrils, closing as soon as the foot valve is depressed and not opening until the valve is released, notwithstanding the Selfeedril has already retracted.

10.2 The clamp has 38mm stroke, but it should be set up with not more than 6mm gap to the face of the workpiece. This precaution will prevent fingers from being nipped.

## 11 GUARDS and SAFETY

11.1 The form of guarding adopted will depend upon the arrangement and disposition of Selfeedrils decided upon. Transparent plastic (Perspec) or wire mesh can frequently be arranged to prevent the operators hands from reaching the drilling area.

11.2 Guards SF119 (for N type Selfeedrils) and SF120 (for A type) are available. These are individual guards which can be set up to prevent the operators hands from passing between the drill bit and the workpiece.

## 12 DUST EXTRACTION

12.1 Arrangements for dust extraction need to be contrived according to

the configuration of the Selfeedril installation. Individual hoods which enclose each Selfeedril separately - and also act as guards - are available.

- 12.2 It is a legal responsibility under the Safety at Work etc Act 1974 adequately to guard, and to extract dust.

www.DaltonsWadkin.com

### ADJUSTMENT

The SELFEDRIL advances the full feed stroke, either  $1\frac{1}{2}''$  – 38 mm or  $2\frac{1}{2}''$  – 57 mm, according to type. Rapid approach can be set for first part of stroke in increments of  $\frac{1}{4}''$  – 6 mm. Feed rate is variable on remaining portion of stroke.

### RAPID APPROACH

To adjust hold KNURLED SLEEVE 83 and turn KNURLED KNOB 25. Ensure figure registers centrally in the "window". Each increment measures  $\frac{1}{4}''$  – 6 mm, hence figure 4 for example, indicates  $1''$  – 25 mm of rapid approach.

### FEED RATE

To adjust hold KNURLED KNOB 25 and turn KNURLED SLEEVE 83. Right hand decreases feed rate, left handed increases. Set feed rate to suit breakthrough. Ensure rapid approach setting is not disturbed, SELFEDRIL will not feed unless figure is central in "window".

### RUNNING MAINTENANCE

The CONTROLLER is filled with pneumatic oil. When fully charged compensating PISTON 23 protrudes approximately 4 mm. As oil is lost the protrusion will decrease. The CONTROLLER should be recharged before the dimension reduces to zero. To recharge position SELFEDRIL vertically, CONTROLLER up. Hold KNURLED NUT 25 and unscrew STOPPER 76. Pour in oil until lowest thread is covered. Advance PISTON 19 by pulling forward on the AIR MOTOR. Repeat two or three times until oil is worked through. Replace STOPPER 76. N.B. Do not over-fill and create internal pressure by forcing STOPPER 76.

In normal working conditions a CONTROLLER should require only minimum attention. If oil loss is troublesome check for 'O' ring failure.

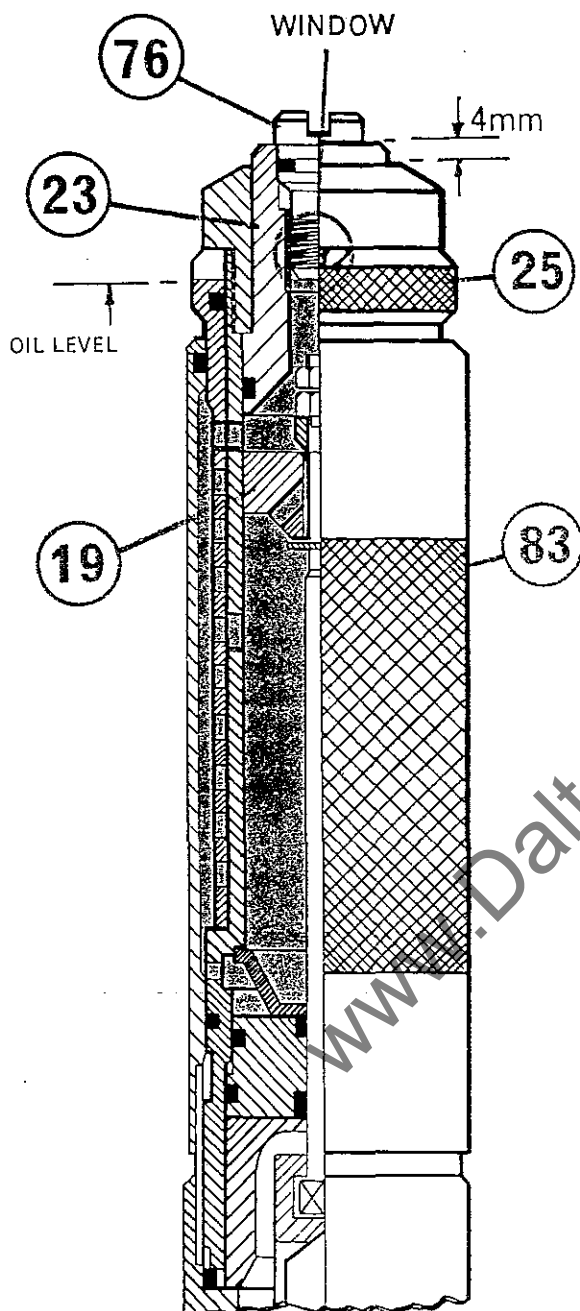

**Component Identification**

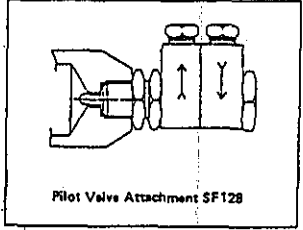
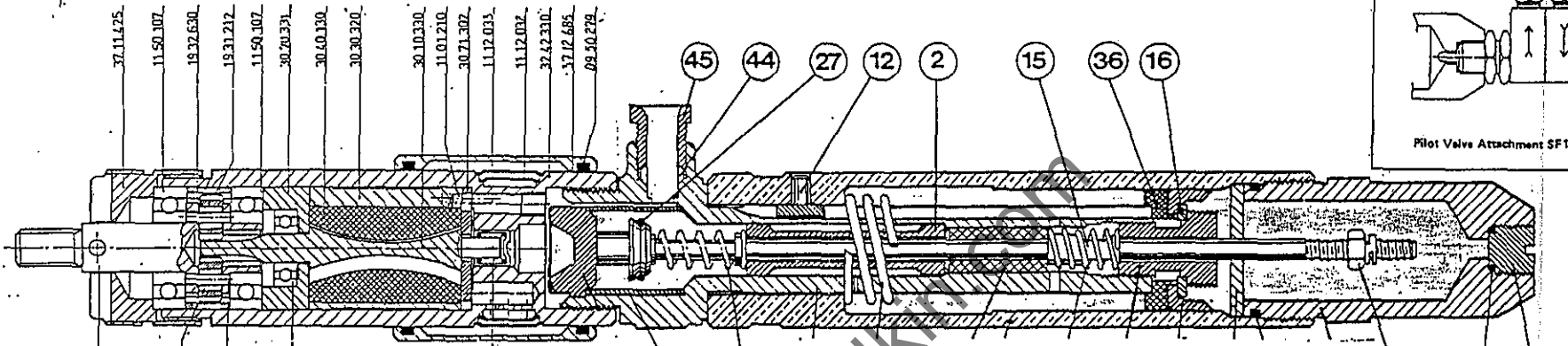

'G' Type Air Motor component identification diagram  
Models P and R - 3000 rpm - ref 10/30

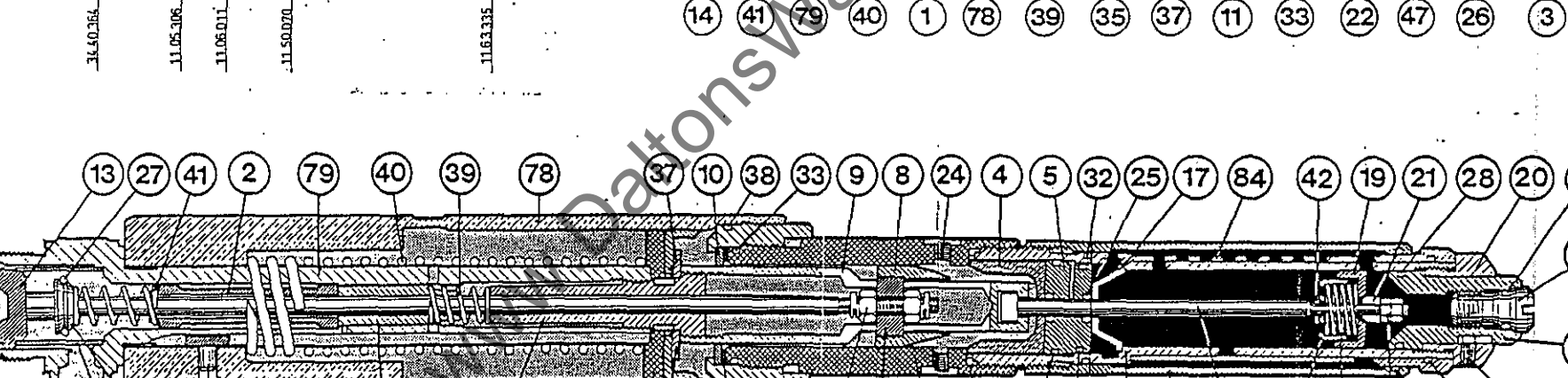

NC AC & WC Oilmete Controller component identification diagram

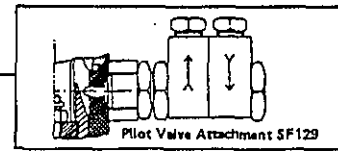

57AC & WC Selffeed Mechanism component identification diagram



ITEM NUMBER	PART NUMBER	DESCRIPTION	C57AC	C57AU	C57AC	C57NU	C57AC
1	1c1000	Shuttle Valve	*	*	*	*	*
2	1c1003	Stop Plug	*	*	*	*	*
3	1c1009	End Plug	*	*	*	*	*
4	1c1011	Sealing Bush	*	*	*	*	*
5	1c1012	Sealing Ring	*	*	*	*	*
6	1c1013	Reversing Nut	*	*	*	*	*
7	1c1014	Shim	*	*	*	*	*
8	1c1015	Reversing Cone	*	*	*	*	*
9	1c1016-2	Tension Sleeve	*	*	*	*	*
10	1c1017	Reversing Ring	*	*	*	*	*
11	1c1018	Reversing Plate	*	*	*	*	*
12	1c1019	Keying Pin	*	*	*	*	*
13	1c1020	Stop Valve Cushion	*	*	*	*	*
14	1c1021	Feed Air Filter	*	*	*	*	*
15	1c1022-2	Stop Valve	*	*	*	*	*
16	1c1023-1	Clamp Ring	*	*	*	*	*
16	1c1023-2	Clamp Ring	*	*	*	*	*
17	1c1024	Control Filter	*	*	*	*	*
18	1c1025	Feed Valve Stem	*	*	*	*	*
19	2/1c1028	Piston	*	*	*	*	*
20	1c1029	Retaining Plug	*	*	*	*	*
21	1c1030	Feed Valve	*	*	*	*	*
22	1c1031-2	End Cap	*	*	*	*	*
23	1c1032	Plunger	*	*	*	*	*
24	1c1036-1	2BA Grubscrew x 3/16"	4	4	4	4	4
25	1c1046-8	'O' Ring	2	2	2	2	2
26	1c1046-11	'O' Ring	1	1	1	1	1
27	1c1046-13	'O' Ring	1	1	1	1	1
28	1c1046-18	'O' Ring	1	1	1	1	1
29	1c1046-20	'O' Ring	1	1	1	1	1
30	1c1046-21	'O' Ring	1	1	1	1	1
31	1c1046-23	'O' Ring	1	1	1	1	1
32	1c1046-24	'O' Ring	1	1	1	1	1
33	1c1046-25	'O' Ring	2	2	2	2	2
34	1c1046-26	'O' Ring	1	1	1	1	1
35	1c1048-2	Piston Screw	1	1	1	1	1
36	1c1049-1	Piston	1	1	1	1	1
36	1c1049-2	Piston	1	1	1	1	1
37	1c1050-1	Piston Washer	1	1	1	1	1
37	1c1050-2	Piston Washer	1	1	1	1	1
38	1c1051-30	'O' Ring	1	1	1	1	1
39	1c1052-3	Spring	19 31 120	2	2	2	2
40	1c1052-4	Spring	19 31 210	2	2	2	2
40	1c1052-5	Spring	19 31 212	2	2	2	2
			19 31 220	2	2	2	2
41	1c1052-8	Spring	19 31 418	2	2	2	2
42	1c1053-8	'E' Clip	19 31 424	2	2	2	2
43	1c1054	Adaptor Bush	19 31 520	2	2	2	2
46	1c1091-3	4BA Nut	19 32 630	2	2	2	2
47	1c1099-3	2BA S/L Nut	19 32 748	1	1	1	1
			19 32 840	1	1	1	1
76	1c1150	Filler Plug	1	1	1	1	1
77	1c1151-2	2BA Grubscrew x 5/16"	1	1	1	1	1
78	4c1000-1	Feed Barrel	1	1	1	1	1
78	4c1000-2	Feed Barrel	1	1	1	1	1
78	4c1000-3	Feed Barrel	1	1	1	1	1
78	4c1000-4	Feed Barrel	1	1	1	1	1
78	4c1000-6	Feed Barrel	1	1	1	1	1
79	4c1001-2	Drill Carrier	1	1	1	1	1
80	4c1003-2	Controller Coupling	1	1	1	1	1
82	4c1008	Control Cylinder	1	1	1	1	1
83	4c1009	Feed Sleeve	1	1	1	1	1
84	4c1013	Approach Sleeve	1	1	1	1	1
85	2/1c1168	Spring	1	1	1	1	1
86	1c1169	Spring Cuo	1	1	1	1	1

10/6 - P and R type 600 rpm - See diagram SG1066/10/6  
 10/10 - " " 1000 rpm - " /10/10  
 10/30 - " " 3000 rpm - " /10/30  
 10/40 - " " 4000 rpm - " /10/40

14/6 - S type 600 rpm - See diagram SG1066/14/6  
 14/20 - " " 2000 rpm - " /14/20  
 14/30 - " " 3000 rpm - " /14/30

ITEM NUMBER	PART NUMBER	DESCRIPTION	10/6	10/10	10/30	10/40	14/6	14/20	14/30
			09 50 279	2	2	2	2		
			11 01 210	1	1	1	1	1	1
			11 01 212	1	1	1	1	1	1
			11 03 036	1	1	1	1	1	1
			11 05 206	20	20	20			
			11 05 208	20	18		30	30	
			11 05 306	16	16				
			11 05 814	2	2	2	2	2	
			11 06 011	2	2	2	2	2	
			11 06 013	2	2	2	2	2	
			11 06 212	2	2	2	2	2	
			11 06 515				2	2	
			11 12 032	1	1	1	1		
			11 12 033	1	1	1	1		
			11 15 243	1	1	1	1		
			11 17 225	1	1	1	1		
			11 50 070	1	1	1	1		
			11 50 080	1	1	1	2	2	2
			11 50 107	3	3	2	2		
			11 50 135	1	1	1	1	1	1
			11 50 171	1	1	1	2	2	2
			11 50 175	1	1	1	1	1	1
			11 62 034	1	1	1	2	2	
			11 63 045	1	1	1	1	1	1
			11 63 335	1	1	1	1	1	1
			19 31 120	2	2	2	2	2	
			19 31 210	2	2	2	2	2	
			19 31 212	2	2	2	2	2	
			19 31 220	2	2	2	2	2	
			19 31 418	2	2	2	2	2	
			19 31 424	2	2	2	2	2	
			19 31 520	2	2	2	2	2	
			19 32 630	2	2	1	1	1	1
			19 32 748	1	1	1	1	1	1
			19 32 840	1	1	1	1	1	1

ITEM NUMBER	PART NUMBER	DESCRIPTION	10/6	10/10	10/30	10/40	14/6	14/20	14/30
			30 10 323	1	1	1	1	1	1
			30 10 325	1	1	1	1	1	1
			30 10 330	1	1	1	1	1	1
			30 10 332	1	1	1	1	1	1
			30 30 320	1	1	1	1	1	1
			30 30 425	1	1	1	1	1	1
			30 40 130	4	4	4	4	4	4
			30 40 230	5	5	5	5	5	5
			30 70 331	1	1	1	1	1	1
			30 70 333	1	1	1	1	1	1
			30 70 428	1	1	1	1	1	1
			30 71 302	1	1	1	1	1	1
			30 71 428	1	1	1	1	1	1
			32 18 508	1	1	1	1	1	1
			32 42 330	1	1	1	1	1	1
			32 42 340	1	1	1	1	1	1
			32 42 435	1	1	1	1	1	1
			32 42 446	1	1	1	1	1	1
			34 40 360	1	1	1	1	1	1
			34 40 364	1	1	1	1	1	1
			34 40 366	1	1	1	1	1	1
			34 40 368	1	1	1	1	1	1
			34 40 475	1	1	1	1	1	1
			34 40 675	1	1	1	1	1	1
			34 40 677	1	1	1	1	1	1
			34 43 340	1	1	1	1	1	1
			34 43 344	1	1	1	1	1	1
			34 43 462	1	1	1	1	1	1
			37 10 632	1	1	1	1	1	1
			37 11 425	1	1	1	1	1	1
			37 12 625	1	1	1	1	1	1
			37 12 685	1	1	1	1	1	1
			37 82 425	1	1	1	1	1	1

When ordering Spare Parts, Quote -

1. Data Sheet No. SG1066
2. Item No.
3. Motor No.
4. Feed Mechanism Reference
5. Serial Number





### Component Identification

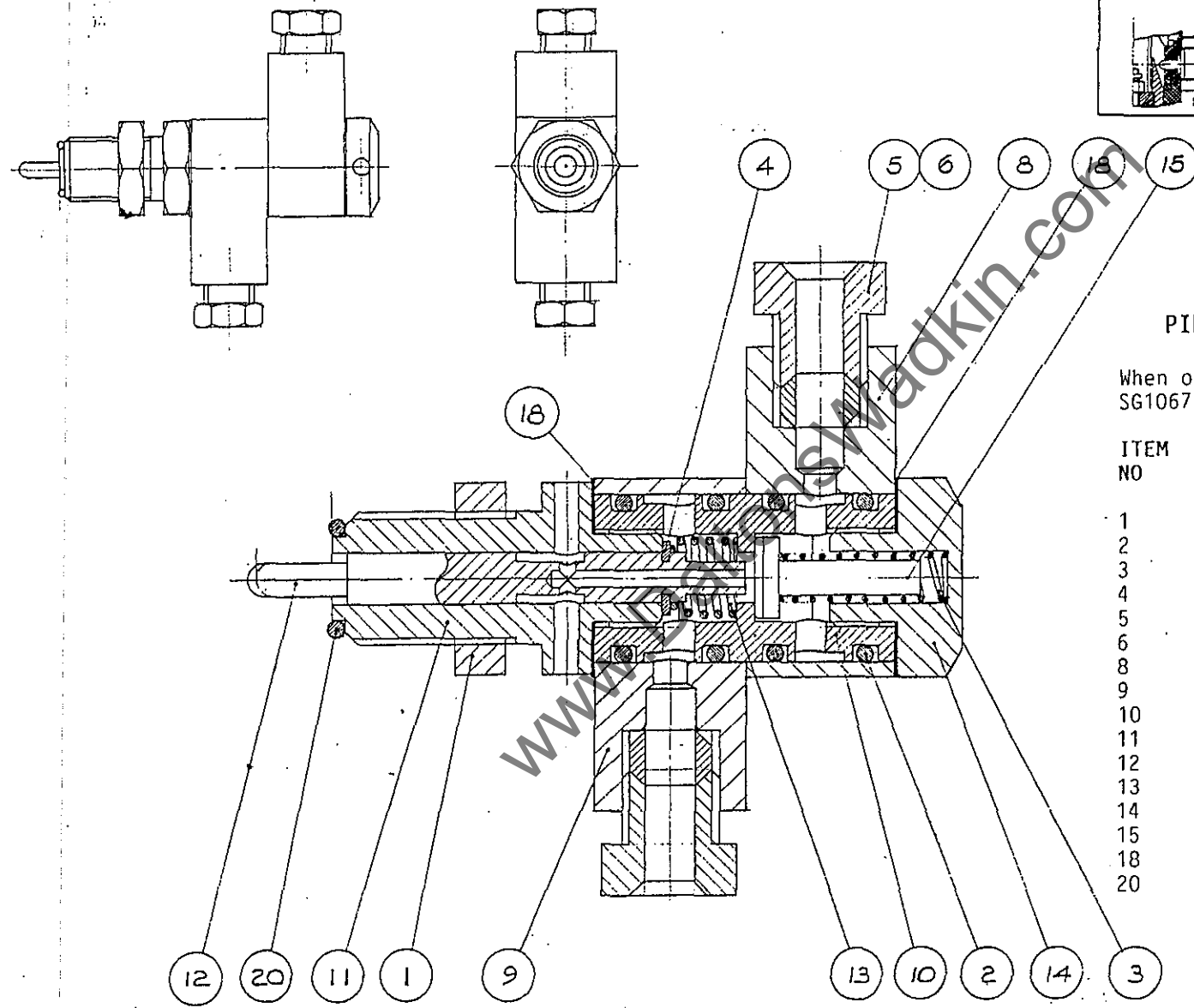
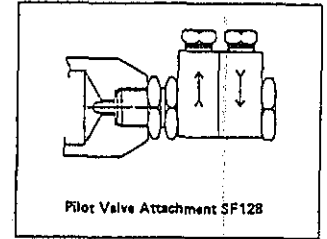
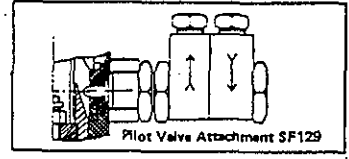

### PILOT VALVES SF128 & SF129

When ordering spares refer to Data Sheet SG1067 and quote Item No.

ITEM NO	PART NO	DESCRIPTION
1	1C1006	Locknut
2	1C1046-14	'O' Ring $\frac{3}{16}$ " o/dia
3	1C1052-1	Compression Spring
4	1C1053-8	5/32" dia 'E' Clip
5	1C1080-3	3/16" dia Tube Sleeve
6	1C1081-3	3/16" dia Tube Nut
8	1C1171	Inlet Connection
9	1C1171	Outlet Connection
10	1C1172	Sleeve
11	1C1173	Nose
12	1C1174	Valve Stem
13	1C1175	Compression Spring
14	1C1176	End Plug
15	1C1177	Jumper Stem & Pad
18	1C1180	Sealing Washer
20	1C1046-11	'O' Ring 5/16" i/dia

12. Regulatory Information.

602664-04 06/03/1989

Page 1

Material Safety Data Bulletin (MSDB)

MOBIL DTE 11

TRANSPORT CLASSIFICATION:

ICAO/IATA - DGR:
IMO/IMDG - Code:
RID/ADR:

HAZARD LABELLING:

UK CPL / EEC Classification: Not applicable.
Risk Phrases: Not applicable.
Safety Phrases: Not applicable.
Contains: Not applicable
Substance Identification Number: Not applicable

OTHER REGULATIONS:

Governmental Inventory Status: Not established.
COSHH Regulations: Product reviewed and no action under COSHH considered necessary.

THE FOLLOWING PRODUCT COMPONENTS ARE CITED ON THE LISTS BELOW:

CHEMICAL NAME CAS NUMBER LIST CITATIONS

\*\*\* NO COMPONENT CITATIONS \*\*\*

--- KEY TO LIST CITATIONS ---

1 = ACGIH, 2 = IARC, 3 = NTP, 4 = UK OEL

--- IARC AND NTP INCLUDE CARCINOGENIC LISTINGS ---

NOTE: MOBIL PRODUCTS ARE NOT FORMULATED TO CONTAIN PCBS OR NITROSAMINES.

1. Product Identification.

PRODUCT NAME: MOBIL DTE 11
SUPPLIER: Mobil Oil Company Limited
HEALTH EMERGENCY TELEPHONE: 01-828-9777
CHEMICAL NAMES AND SYNONYMS: Pet. hydrocarbons and additives
INTENDED USE: Hydraulic oil

NOTE: THIS PRODUCT SHOULD NOT BE USED FOR ANY OTHER PURPOSE WITHOUT EXPERT ADVICE.

2. Typical Properties For Health Evaluations.

Consult Product Data Sheet for specific details.

APPEARANCE: Amber liquid
ODOUR: Mild
pH: NA
VISCOSITY AT 40 C, cSt: 15.5
FLASH POINT C: >166 (IP 36 / ASTM D-92)
MELTING POINT C: NA
POUR POINT C: -40
BOILING POINT C: >316
RELATIVE DENSITY, 15/4 C: 0.865
SOLUBILITY IN WATER: Negligible
VAPOUR PRESSURE-mm Hg 20 C: < .1
NA=NOT APPLICABLE NE=NOT ESTABLISHED D=DECOMPOSES

3. Composition.

Table with 4 columns: POTENTIALLY HAZARDOUS COMPONENTS, WT % (APPROX), EXPOSURE LIMITS (MG/M3, PPM), SOURCES\* (AND NOTES). Rows include NONE, Severely refined mineral oils (>90), and Additives / ingredients (<10).

SEE SECTION 12 FOR ADDITIONAL REGULATORY INFORMATION.

NOTE: LIMITS SHOWN FOR GUIDANCE ONLY. FOLLOW APPLICABLE REGULATIONS.

\* SOURCES: U=UK OEL, A,A\*=ACGIH TLV, O=OSHA PEL, M=MOBIL, S=SUPPLIER

4. Health Hazard Data.

--- INCLUDES AGGRAVATED MEDICAL CONDITIONS, IF ESTABLISHED ---
EFFECTS OF OVEREXPOSURE: Slight skin irritation. Prolonged, repeated skin contact with low viscosity materials may defat the skin resulting in possible irritation and dermatitis.

13. Appendix

PREPARED BY: MOBIL OIL CORPORATION
ENVIRONMENTAL, HEALTH & SAFETY DEPARTMENT, PRINCETON, NJ. USA.
FOR FURTHER INFORMATION, CONTACT:
Mobil Oil Company Limited
The Clock House
Frogmoor, High Wycombe, Bucks. HP13 5DB
Tel: 0494-459222

\*\*\*\*\*
FOR MOBIL USE ONLY: ( FILL NO: RL1305Z) RD820823 APPROVE REVISED:
30/01/89

\*\*\*\*\*
It is believed that all the information given in this bulletin (which supersedes all previous issues) is accurate at the time of printing. Such information is offered in good faith but without guarantee and without any representation that the product concerned is suitable for any particular use or application. Without limitation of the foregoing, nothing herein shall be construed as a recommendation for uses which infringe valid patents or as extending any licence under valid patents.

Mobil pursues a policy of constant research and development aimed at product improvement and, therefore, reserves the right to change formulation, specification and characteristics of its products without notice. User should verify current specifications with Mobil and ascertain that products are suitable for intended uses or applications.

Where the information provided herein discloses a potential hazard or hazardous ingredient, adequate warning must be provided to employees and users and appropriate precautions taken, including the practice of good industrial hygiene.

## 5. Special Protection Information.

MOBIL PERSONAL PROTECTIVE EQUIPMENT CODE (MPPEC): A

**EYE PROTECTION:** No special equipment required.  
**SKIN PROTECTION:** No special equipment required. However, good personal hygiene practices should always be followed.  
**RESPIRATORY PROTECTION:** No special requirements under ordinary conditions of use and with adequate ventilation.  
**VENTILATION:** No special requirements under ordinary conditions of use and with adequate ventilation.

## 6. Emergency and First Aid Procedures.

--- FOR PRIMARY ROUTES OF ENTRY ---

**EYE CONTACT:** Flush with water.  
**SKIN CONTACT:** Wash contact areas with soap and water.  
**INHALATION:** Not expected to be a problem.  
**INGESTION:** DO NOT INDUCE VOMITING. Administer vegetable oil. Obtain medical attention or call an ambulance. (Note to Physician: Material if aspirated into the lungs may cause chemical pneumonitis. Gastric lavage should only be given after endotracheal intubation. Treat appropriately).

## 7. Fire and Explosion Hazard Data.

**FLASH POINT C:** >166 **IP CLASSIFICATION:** Unclassified  
**FLAMMABLE LIMITS. LEL:** .6 **UEL:** 7.0  
**EXTINGUISHING MEDIA:** Foam, dry powder, CO<sub>2</sub>, Halon (BCF) and water fog.  
**SPECIAL FIRE FIGHTING PROCEDURES:** Water or foam may cause frothing. Use water to keep fire exposed containers cool. Water spray may be used to flush spills away from exposures. For fires in enclosed areas, firefighters MUST use self-contained breathing apparatus. Prevent runoff from fire control or dilution from entering waterways or drinking water supply.  
**UNUSUAL FIRE AND EXPLOSION HAZARDS:** None.  
**NFPA HAZARD ID: HEALTH:** 0, **FLAMMABILITY:** 1, **REACTIVITY:** 0  
 Codes are assigned 0-4 for each category, 0 indicating minimum hazard.

## 8. Reactivity Data.

**STABILITY (THERMAL, LIGHT, ETC.):** Stable.  
**CONDITIONS TO AVOID:** Extreme heat.  
**INCOMPATIBILITY (MATERIALS TO AVOID):** Strong oxidisers.  
**HAZARDOUS DECOMPOSITION PRODUCTS:** Carbon monoxide.  
**HAZARDOUS POLYMERISATION:** Will not occur.

## 9. Spill or Leak Procedure and Waste Disposal.

**ENVIRONMENTAL IMPACT:** Report spills as required to appropriate authorities such as the local Environmental Health Officer or Fire Brigade. If spills are likely to enter any drain, waterway or groundwater, contact the Area Water Authority.  
**PROCEDURES IF MATERIAL IS RELEASED OR SPILLED:** Contain and adsorb on fire retardant treated sawdust, diatomaceous earth, etc. Shovel up and dispose of at an appropriate licensed waste disposal site in accordance with current applicable laws and regulations and product characteristics at time of disposal.  
**WASTE DISPOSAL:** Product is suitable for burning in an enclosed, controlled burner for fuel value or disposal by supervised incineration. Such burning may be limited by the controlling authority. In addition, the product is suitable for processing by an approved recycling facility or can be disposed of at any licensed waste disposal site. Use of these methods is subject to user compliance with applicable laws and regulations and consideration of product characteristics at time of disposal.

## 10. Additional Handling and Storage Information.

No special precautions required.

## 11. Toxicological Data.

---ACUTE TOXICOLOGY---

MATERIAL HAZARD CODE (MHC):	Toxicity		Irritation	
	Oral	Dermal	Inhal.	Eye Skin
Mobil assigned codes 0-4 with 0 indicating lowest MHC classification.	1*	1*	NA	0* 1*

**ORAL TOXICITY:** LD50: > 5 g/kg Slightly toxic(estimated) ---Based on testing of similar products and/or the components.  
**DERMAL TOXICITY:** LD50: > 2 g/kg Slightly toxic(estimated) ---Based on testing of similar products and/or the components.  
**INHALATION TOXICITY:** Not applicable ---Harmful concentrations of mists and/or vapours are unlikely to be encountered through any customary or reasonably foreseeable handling, use, or misuse of this product.  
**EYE IRRITATION:** Expected to be non-irritating. ---Based on testing of similar products and/or the components.  
**SKIN IRRITATION:** May cause slight irritation on prolonged or repeated contact. ---Based on testing of similar products and/or the components.

---SUBCHRONIC TOXICOLOGY (SUMMARY)---

Severely solvent refined and severely hydrotreated mineral base oils have been tested at Mobil Environmental and Health Sciences Laboratory at doses significantly higher than those expected during normal industrial exposure. Extensive evaluations showed no adverse effects.

---CHRONIC TOXICOLOGY (SUMMARY)---

The base oils in this product are severely solvent refined and/or severely hydrotreated. Studies of similar oils showed no evidence of carcinogenic effects.