

CASA Part Number:
PLT-CLAMP-BP2JB-MS20

CASA Part Number:
PLT-CLAMP-NEMA34-MS20

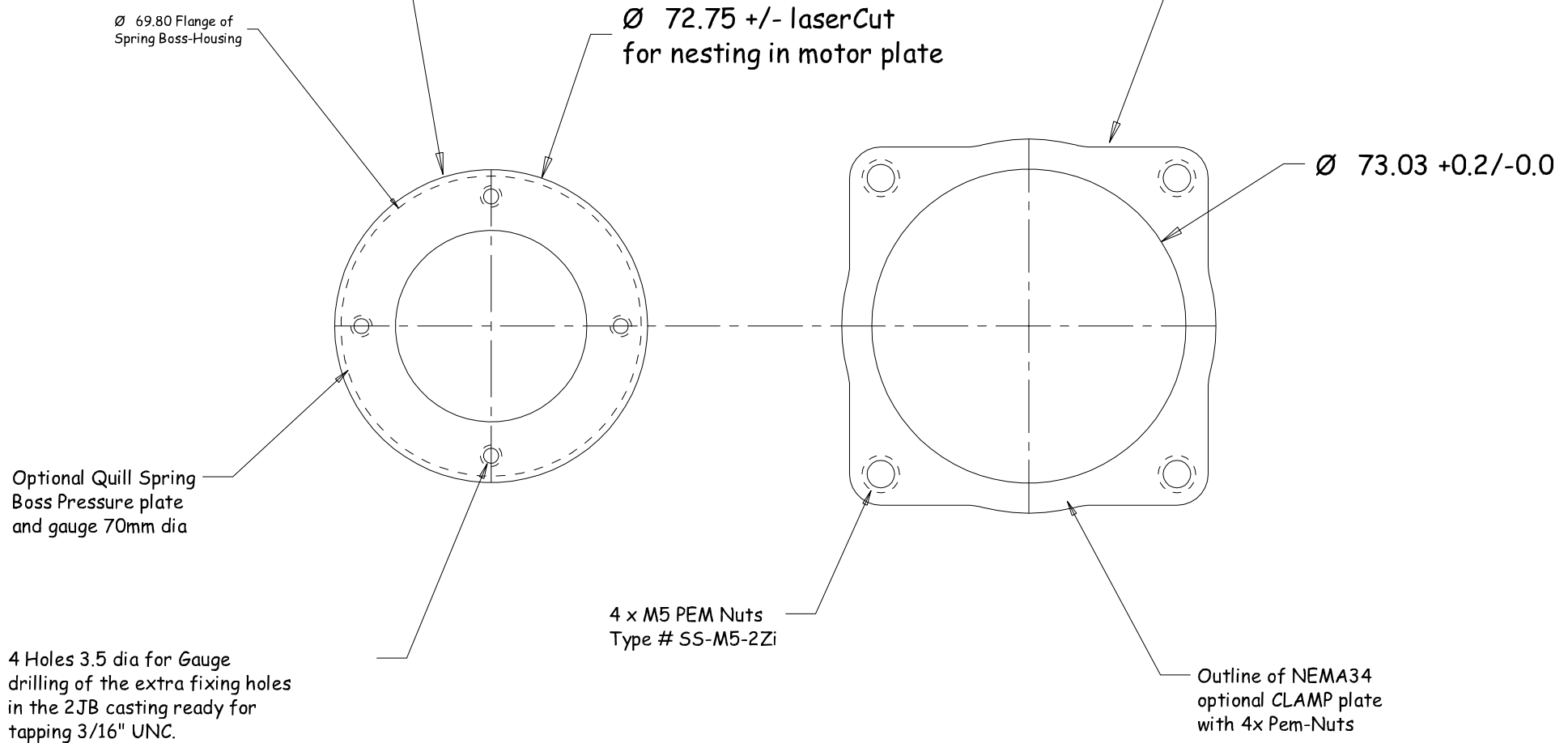

MATERIAL	Steel Plate
ALLOY	2mm Bright CP
EST. AREA	xx mm
EST. WEIGHT	xxx kg/n
EST. PERIPHERY	EXT: xxx mm
	TOT: xxx mm
TOLERANCE	
	0.00mm ±0.1mm
	00.0mm ±0.25mm
	000.0mm ±0.5mm
	0-600mm ±0.1mm
	> 600mm ±0.5mm
BS1474:1987 APPLIES UNLESS OTHERWISE SPECIFIED	
JOB No.	0000

Modular Systems P.O. BOX 38-828, WELLINGTON, NEW ZEALAND TELEPHONE : (64-4) 5687 277 FACSIMILE : (64-4) 5685 161	CUSTOMER :	CASA Modular Systems	SIZE	DRAWING Reference No.	ISSUE					
	DESCRIPTION :	Clamp-Plates for "Z" Axis Quill & NEMA34 Motor	A3	2JB-ClmpPit	A					
	DRAWN :	AWD	DATE :	01/11/07	APPROVED :	?	DWG. SCALE :	1:1	© COPYRIGHT : CASA Modular Systems	ALL RIGHTS RESERVED