

Pin Insertion Tool

These tools with a new style handle are designed to aid the insertion of Terminal Pins. A Terminal Pin is pushed into and lightly held by the end of the tool, and when inserted into a hole in the Veroboard the tool is removed leaving the pin correctly positioned. Although very simple in design and application it will be found that an insertion rate in excess of 1,000 per hour can be achieved.

Part Number	For use with	Colour
IT/2150	0.052" pins	Green
IT/2151	0.040" pins	Orange
IT/11772/4	0.052" miniature terminals	Yellow
IT/11772/5	0.040" miniature terminals	Grey

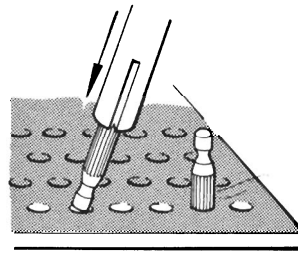
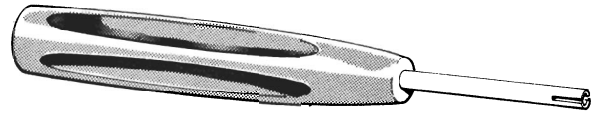

Insertion method types B.C & F

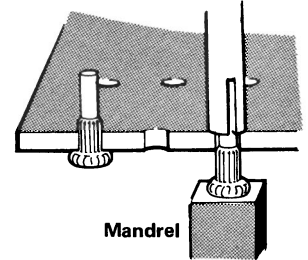

Insertion method types D & E

Card Handles

Attractively styled to suit modern applications, this unique range of PC Card Handles has been specially designed with user requirements in mind.

Two of the handles, Part Numbers 10035 and 10037 have a specially designed clip-on feature, which enables them to be assembled onto a PC Board which has been pre-drilled with one or two holes respectively. Handle Part Number 10036 is attached by means of two 6BA nuts or Chorbet rivets.

All three handles have provision for Card Identification. Part Numbers 10036 and 10037 have three recesses to take self-adhesive identification labels, and Part Number 10035 has three small circular recesses for colour code identification.

Part Numbers 10036 and 10037 are suitable for use with PC Boards mounted at a minimum of 0.4" pitch and when using Part Number 10035 boards can be to a minimum of 0.25 spacing.

All card handles are designed for use on 1/16" PC Board, although Part Number 10036 can accommodate other thicknesses. Noryl is adversely affected by some solvents.

Handles moulded in alternative materials can be supplied.

To fix to a circuit board use:—

1/4" Hex Screw	Part No: 15006/M
Hex Nut	Part No: 17000/M
Crinkle Washer	Part No: 16017

Specification

Material-Noryl: Temperature Range -60 to +100C
 Colours—Add suffixes to the Part No. as shown.
 Eg. Blue large clip on handle: CH/10037/3
 Grey/1 Red/2 Blue/3 Green/4 Yellow/5 Black

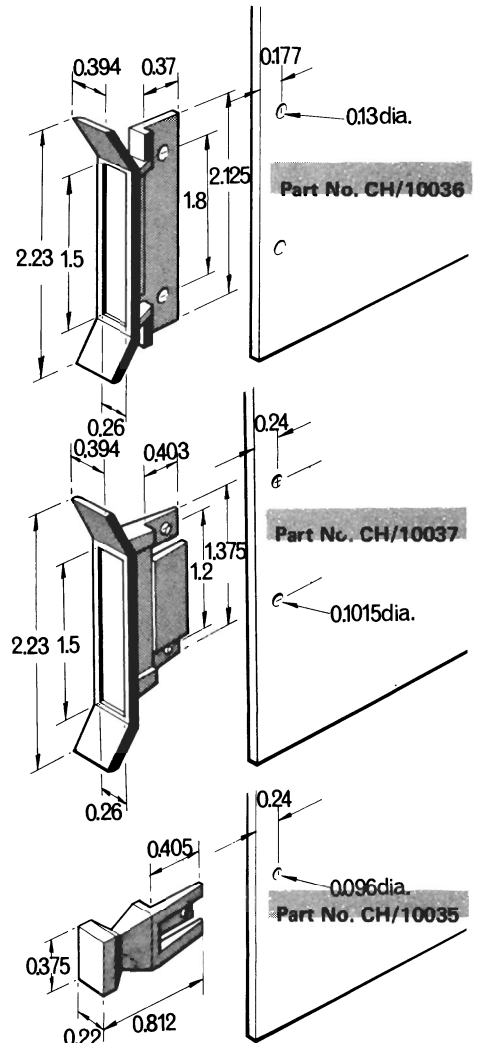

Card Ejectors

Recommended for use on S.R.B.P. or Epoxy Glass P.C. Boards and Epoxy Glass Veroboards. When using connectors with a high withdrawal force (greater than 2.5oz average per contact pair) a maximum connector size of 60 + 60 contacts double sided or 60 contacts single sided is recommended. For connectors with a withdrawal force of 2.5 oz's or less per contact pair a large number of contact ways maybe used to a maximum of 89 + 89 double sided or 89 contacts single sided.

For use with 1/16" PC Board only. Material—Black Noryl. Sold in packets of ten pairs, complete with tension pins.

